



Read this Owner's Manual thoroughly before operating the equipment. Keep it with the equipment at all times. Replacements are available from Thern, Inc., 5712 Industrial Park Road, Winona, MN 55987, 507-454-2996. www.thern.com

IMPORTANT: Please record product information on page 2. This information is required when calling the factory for service.

ORIGINAL TEXT



ENSIGN

Owner's Manual

For
5PA5 and 5PA10 Ensign Series
Portable Davit Cranes

Two-Year Limited Warranty

Please record the following:

Date Purchased: _____

Crane Model No.: _____

Crane Serial No.: _____

If sold with a winch:

Winch Model No.: _____

Winch Serial No.: _____

This information is required when calling the factory for service.

Thern, Inc. warrants its products against defects in material or workmanship for two years from the date of purchase by the original using buyer, or if this date cannot be established, the date the product was sold by Thern, Inc. to the dealer. To make a claim under this warranty, contact the factory for an RGA number. The product must be returned, prepaid, directly to Thern, Inc., 5712 Industrial Park Road, Winona, Minnesota 55987. The following information must accompany the product: the RGA number, the date of purchase, the description of the claimed defect, and a complete explanation of the circumstances involved. If the product is found to be defective, it will be repaired or replaced free of charge, and Thern, Inc. will reimburse the shipping cost within the contiguous USA.

This warranty does not cover any damage due to accident, misuse, abuse, or negligence. Any alteration, repair or modification of the product outside the Thern, Inc. factory shall void this warranty. This warranty does not cover any costs for removal of our product, downtime, or any other incidental or consequential costs or damages resulting from the claimed defects. This warranty does not cover brake discs, wire rope or other wear components, as their life is subject to use conditions which vary between applications.

FACTORY AUTHORIZED REPAIR OR REPLACEMENT AS PROVIDED UNDER THIS WARRANTY IS THE EXCLUSIVE REMEDY TO THE CONSUMER. THERN, INC. SHALL NOT BE LIABLE FOR ANY INCIDENTAL OR CONSEQUENTIAL DAMAGES FOR BREACH OF ANY EXPRESS OR IMPLIED WARRANTY ON THIS PRODUCT. EXCEPT TO THE EXTENT PROHIBITED BY APPLICABLE LAW, ANY IMPLIED WARRANTY OF MERCHANTABILITY OR FITNESS FOR A PARTICULAR PURPOSE ON THIS PRODUCT IS LIMITED IN DURATION TO THE DURATION OF THIS WARRANTY.

Some states do not allow the exclusion or limitation of incidental or consequential damages, or allow limitations on how long an implied warranty lasts, so the above limitation or exclusion may not apply to you. This warranty gives you specific legal rights, and you may also have other rights which vary from state to state.

Note: Thern, Inc. reserves the right to change the design or discontinue the production of any product without prior notice.

About This Manual

The Occupational Safety and Health Act of 1970 states that it is the employer's responsibility to provide a workplace free of hazard. To this end, all equipment should be installed, operated, and maintained in compliance with applicable trade, industrial, federal, state, and local regulations. It is the equipment owner's responsibility to obtain copies of these regulations and to determine the suitability of the equipment to its intended use.

This Owner's Manual, and warning labels attached to the equipment, are to serve as guidelines for hazard-free installation, operation, and maintenance. They should not be understood to prepare you for every possible situation.

The information contained in this manual is applicable only to the Thern 5PA5 and 5PA10 Ensign Series Portable Davit Cranes. Do not use this manual as a source of information for any other equipment.

The following symbols are used for emphasis throughout this manual:

▲WARNING

Failure to follow 'WARNING!' instructions may result in equipment damage, property damage, and/or serious personal injury.

▲CAUTION

Failure to follow 'CAUTION!' instructions may result in equipment damage, property damage, and/or minor personal injury.

Important!

Failure to follow 'important!' instructions may result in poor performance of the equipment.

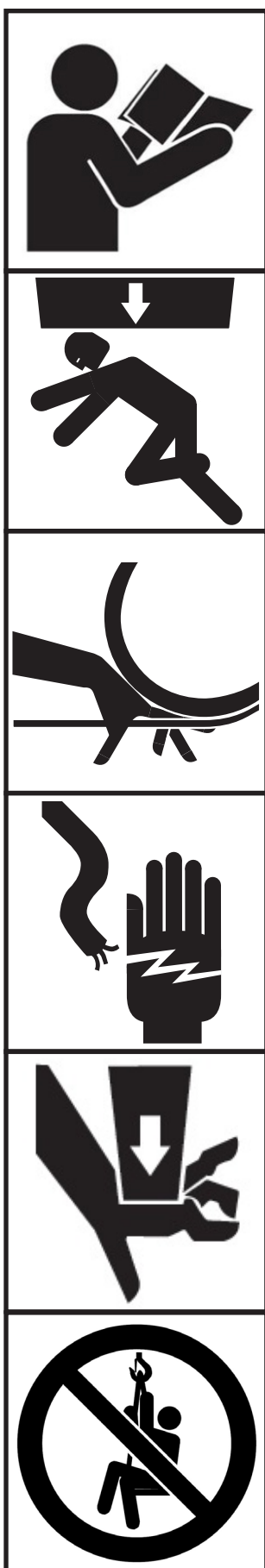

Suggestions for Safe Operation

⚠WARNING

DO the following:

Read and comply with the guidelines set forth in this Owner's Manual. Keep this manual, and all labels attached to the crane, readable and with the equipment at all times. Contact Thern, Inc. for replacements.

Check lubrication before use.

Install the wire rope securely to the winch drum.

Keep at least 4 wraps of wire rope wound on the drum at all times, to serve as anchor wraps. With less than 4 wraps on the drum the wire rope could come loose, causing the load to escape.

Keep hands away from sheaves, gears, wire rope, and other moving parts.

Disconnect electric power before servicing the equipment.

Keep all unnecessary personnel away from crane while in operation.

Keep out of the path of the load, and out of the path of a broken wire rope that might snap back and cause injury.

DO NOT do the following:

Do not lift people, or things over people. Do not walk or work under a load or in the line of force of any load.

Do not exceed the load rating of the crane or any other component in the system. To do so could result in failure of the equipment.

Do not use more than one crane to move a load that exceeds the load rating of a single crane. A shift in load weight could overload the equipment.

Do not use damaged or malfunctioning equipment. To do so could result in failure of the equipment.

Do not modify the equipment in any way. To do so could cause equipment failure.

Do not wrap the wire rope around the load. This damages the wire rope and could cause the load to escape. Use a sling or other approved lifting device.

Do not operate the crane with guards removed or improperly installed.

Do not divert your attention from the operation. Stay alert to the possibility of accidents, and try to prevent them from happening.

Do not jerk or swing the load. Avoid shock loads by starting and stopping the load smoothly. Shock loads overload the equipment and may cause damage.

Do not use the crane and winch components for any use other than for their original intended function.

Do not use the crane to drag or pull loads. This will create side pulls, which could damage the equipment or cause the load to tip.

Do not leave a suspended load unattended. Place the load on the ground if it must be left unattended.

Do not adjust the winch brake with the load suspended.

Do not operate or apply loads without all pins securely in place.

Do not adjust the sheave position or boom angle while the crane is loaded.

1.1 Installing the Crane

Important!

- A qualified professional should inspect or design the foundation to insure that it will provide adequate support.
- Locate the crane so it will be visible during the entire operation.

⚠WARNING

Do not install the crane in an area defined as hazardous by the National Electric Code, unless installation in such an area has been thoroughly approved.

Do not install the crane near corrosive chemicals, flammable materials, explosives, or other elements that may damage the crane or injure the operator. Adequately protect the crane and the operator from such elements.

Position the crane so the operator can stand clear of the load, and out of the path of a broken wire rope that could snap back and cause injury.

Attach the crane to a rigid and level foundation that will support the crane and its load under all load conditions, including shock loading.

1.1.1 CONSULT APPLICABLE CODES AND REGULATIONS for specific rules on installing the equipment.

1.1.2 LOCATE THE CRANE in an area clear of traffic and obstacles that could interfere with operation. Make sure the crane is accessible for maintenance and operation.

1.1.3 INSTALL THE CRANE on a level surface. **An uneven surface may cause the boom to rotate in the direction the mast is leaning.**

1.1.4 FASTEN THE BASE securely to the foundation to withstand applicable overturning moments and mounting bolt reaction. See Table 1.

a FOR STANDARD PRODUCTS referred to in this manual, use:

- 5PA5 - 1/2 in. coarse thread fasteners, Grade 5 or better. Recommended torque without lubrication is 75 ft-lb.
- 5PA10 - 5/8 in. coarse thread fasteners, Grade 5 or better. Recommended torque without lubrication is 150 ft-lb.

Refer to manufacturer's instructions for other fastener types with specific torque or installation instructions.

b NON-STANDARD PRODUCTS that vary from the original design may have different fastening requirements. Contact a structural engineer or Thern, Inc. for this information.

TO COMPLY WITH LOCAL CODES, CONTACT A QUALIFIED PROFESSIONAL TO OBTAIN PROPER STRUCTURE OR FOUNDATION SPECIFICATIONS FOR THE MOUNTING OF THERN PRODUCTS.

Table 1 - Crane Reactions²

Crane Model	Mast Moment		Suggested Bolt Size	Pedestal Base		Wall Mount Base			
				Axial Force per Bolt ¹		Axial Force per Bolt ¹		Shear Force per Bolt	
5PA5	9,410 in-lbs	1,064 N-m	1/2 inch (M12)	880 lbs	3,915 N	680 lbs	3,025 N	540 lbs	2,403 N
5PA10	32,730 in-lbs	3,699 N-m	5/8 inch (M16)	1,380 lbs	6,139 N	1,280 lbs	5,694 N	1,060 lbs	4,716 N

1 Force in tension.

2 This information may change without prior notice. It is the responsibility of the installer and/or end user to ensure the most current information is used.

1.2 Assembling the Crane

Important!

- Inspect the crane during assembly according to the Instructions for Periodic Inspection. This will give you a record of the condition of the crane with which to compare future inspections.
- Save all boxes and crates that the crane was shipped in, use them again if you need to repackage the crane.
- Contact the factory immediately if any parts are missing or damaged.
- Do not overtighten fasteners, this may strip threads or cause damage to other parts.

⚠ CAUTION

When installing the mast, ensure the mast is fully and properly seated on the pin in the bottom of the base.

When installing the boom, hold the boom securely so it does not move abruptly causing damage or injury.

- 1.2.1 STUDY PARTS DRAWINGS to understand how the crane is assembled. See pages 18-21.
- 1.2.2 LUBRICATE PINS and other components prior to assembly. See Section 3.2 - Lubricating the Crane
- 1.2.3 INSTALL THE BASE. See Section 1.1 for additional information and crane overturning moments and mounting bolt reaction forces.
- 1.2.4 INSTALL THE BEARING in the base. Position the bearing so that the alignment pin and notch in base are aligned. Bearing must set level on base. See Figure 1.
- 1.2.5 ASSEMBLE THE CRANE in the following order.
 - a FASTEN THE WINCH to the mounting plate using the fasteners provided. On some models you will need to use an additional winch adapter plate and fasteners provided to fasten the winch to the crane. **Make sure the winch is positioned correctly with the winch drum facing toward the load. See Figure 4.**
 - b INSTALL THE MAST in the base. Move the mast side-to-side to make sure the bottom of the mast properly seats on the pin in the bottom of the base. **The crane will not be stable unless properly seated. See Figure 5.**
 - c INSTALL THE HANDLE onto the mast using the longer clevis pin and clevis end pins provided. There are three positions for the winch. Locate the clevis pin and handle for the desired winch position.
 - d INSTALL THE WINCH onto the mast. Rotate into position and secure with provided clevis pin and clevis end pins. **Make sure the winch is positioned correctly, with the mast/boom brace plate located on the opposite side as the winch as shown in Figure 5.**
 - e FASTEN THE BOOM to the mast using the clevis pin and clevis end pins provided. **Make sure the boom is positioned correctly as shown in Figure 5.**
 - f INSTALL THE SHEAVE ASSEMBLY on the boom in the desired position for the required hook reach. Secure in place using the clevis pin and clevis end pins provided. See Figure 5.

Figure 1 – Base Bearing

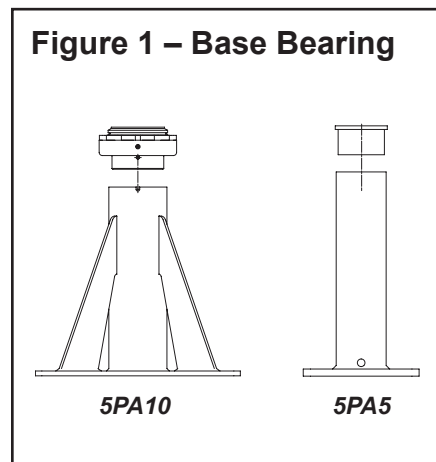
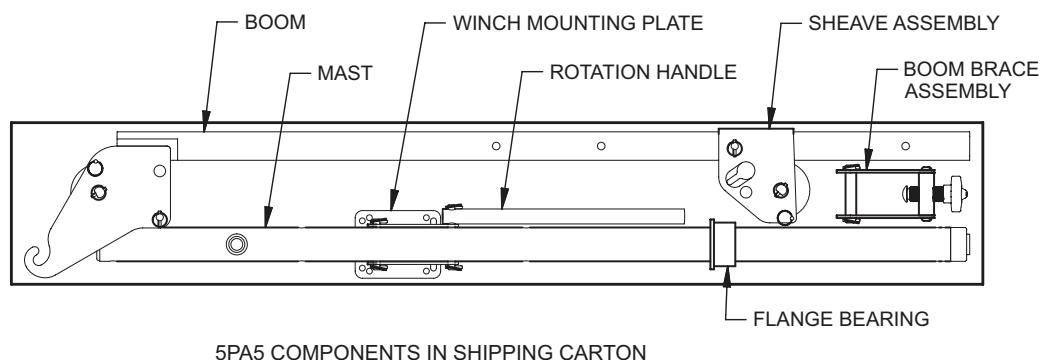
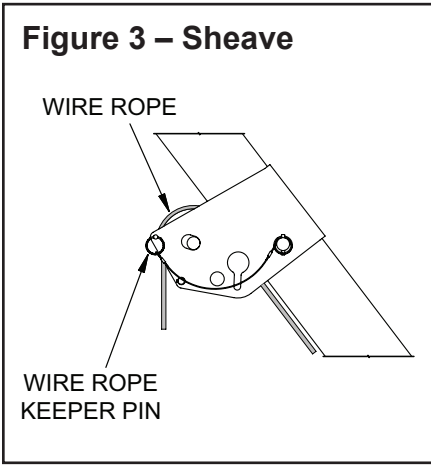
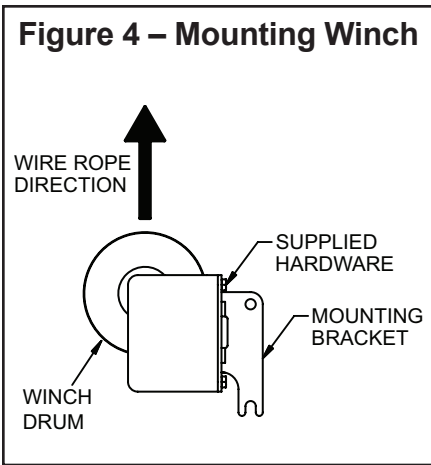

Figure 2 – Crane Packaging





- 1.2.4 INSTALL THE WINCH HANDLE on hand winches, or connect electric current on power winches. Refer to instructions in the Winch Owner's Manual.
- 1.2.5 INSTALL THE WIRE ROPE. Use wire rope assemblies in the length specified on pages 22-23.
 - a REMOVE ROPE KEEPER PINS at each sheave to allow rope to be installed.
 - b PASS THE WIRE ROPE over the sheave at the end of the boom.
 - c PASS THE WIRE ROPE over the sheave at the mast.
 - d REINSTALL ROPE KEEPER PINS to prevent the rope from escaping the sheave rope groove. Make sure the wire rope does not make contact with the pins. See Figure 3.
 - e ANCHOR THE WIRE ROPE to the winch drum and wind 4 wraps of wire rope onto the drum to act as anchor wraps. Refer to the instructions in the Winch Owner's Manual.



- 1.2.6 RAISE THE BOOM into position and secure in place with the boom brace assembly as shown in Figure 5. Make sure the tip of the boom brace adjustment screw is correctly positioned with the mast/boom brace plate.
 - a IN SOME SITUATIONS it may be desirable to use the winch to raise the boom into position. Secure the load hook at the rear of the boom as shown in Figure 6. The wire rope must be installed correctly to prevent damage to the rope. Once the boom brace assembly is securely in place, remove the load hook from the rear of the boom.
- 1.2.7 MAKE SURE ALL CLEVIS PINS ARE PROPERLY INSTALLED with all clevis end pins in place to prevent components from shifting during use.
- 1.2.8 ADJUST BOOM ANGLE for the desired reach by turning the boom brace adjustment knob. Do not make adjustments while crane is loaded. See Figure 5.

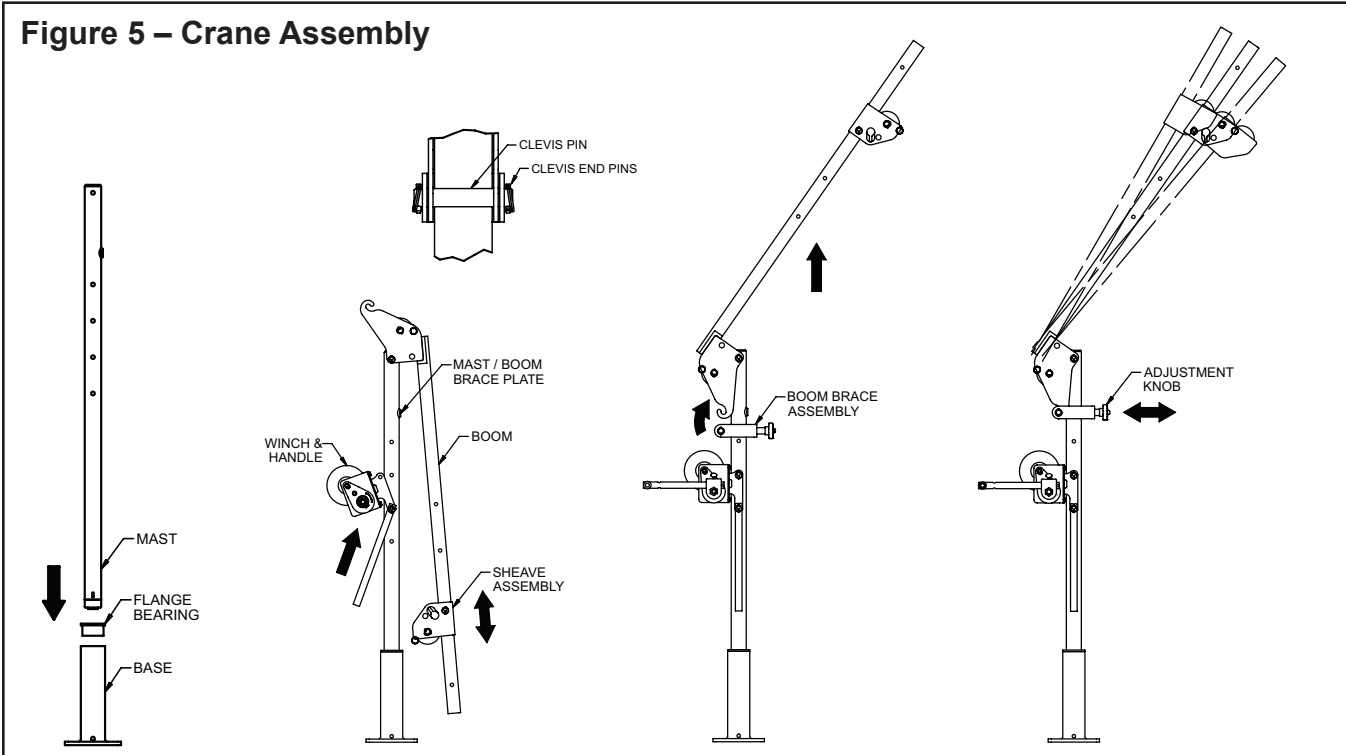

2.1 General Theory of Operation

Important!

- Limit non-uniform winding by keeping tension on the wire rope.
- It is your responsibility to detect and account for different factors affecting the condition and performance of the equipment.

Figure 6 – Raising the Boom

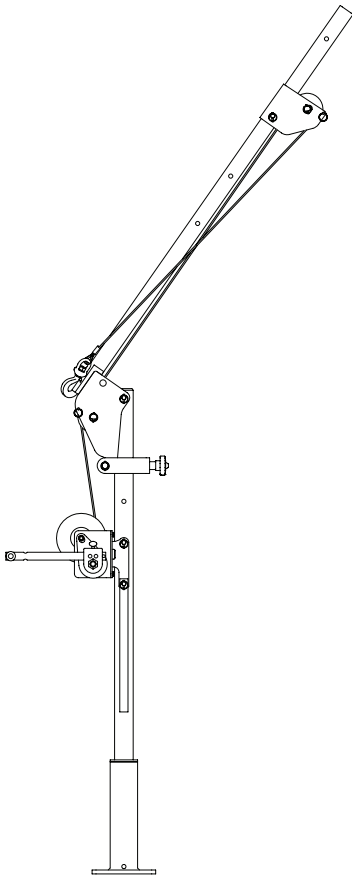

- 2.1.1 THE INTENDED USE of this machinery is to lift and lower loads of its rated capacity or less. It is not for lifting people or things over people.
- 2.1.2 THE FORCE REQUIRED to lift the load must not exceed the load rating of the crane. Consider the total force required to lift the load, not the weight of the load.
- 2.1.3 THIS EQUIPMENT CAN develop forces that will exceed the load rating. It is the responsibility of the equipment user to limit the size of the load. Inspect the equipment regularly for damage according to the instructions contained in this manual.
- 2.1.4 PERFORMANCE RATINGS of the equipment are affected by the position of the boom (hook reach). **Crane load ratings decrease as you extend the reach.** See the Performance Characteristics Tables on pages 22-23.
- LOAD RATING represents the maximum force that can be placed on new equipment.
 - LIFT varies with the position of the boom and sheave and length of the wire rope.
 - REACH varies with the position of the boom and sheave.
- 2.1.5 DUTY RATINGS refer to the type of use the equipment is subject to. Consider the following when determining duty rating.
- ENVIRONMENT: harsh environments include hot, cold, dirty, wet, corrosive, or explosive surroundings. **Protect the equipment from harsh environments when possible.**
 - MAINTENANCE: poor maintenance, meaning poor cleaning, lubrication, or inspection, leads to poor operation and possible damage of the equipment. **Minimize poor maintenance by carefully following the instructions contained in this manual.**
 - LOADING: severe loading includes shock loading and lifting loads that exceed the load rating of the equipment. **Avoid shock loads, and do not exceed the load rating of the equipment.**
 - FREQUENCY OF OPERATION: frequent or lengthy operations increase wear and shorten the life span of gears, bearings, sheaves, and other components. **Increase maintenance of the equipment if used in frequent operations.**
- 2.1.6 AIRBORNE NOISE EMISSIONS vary depending on load and the type of winch being used. Standard configurations do not typically exceed a sound pressure level of 80dB(A) at workstations.
- 2.1.7 VIBRATION LEVELS vary depending on load and type of winch being used. Standard configurations do not typically exceed vibration levels of 2.5 m/s².

CONTACT THE FACTORY FOR ANY ADDITIONAL INFORMATION.

2.2 Preparing for Operation

Important!

- When determining whether the load will exceed the load rating, consider the total force required to move the load.

Figure 7 – Positioning the Boom

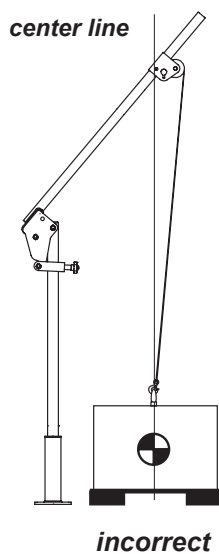
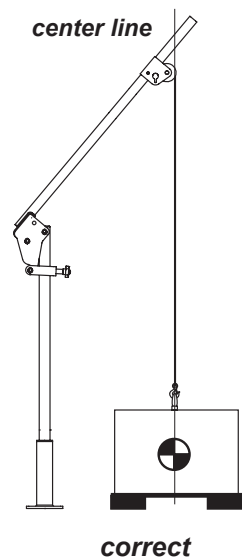

- 2.2.1 CONSIDER THE OPERATION. Do not begin until you are sure you can perform the entire operation without hazard.
- 2.2.2 INSPECT ALL COMPONENTS of the system.
- INSPECT THE CRANE and other equipment according to the Instructions for Frequent Inspection.
 - INSPECT THE WINCH according to the instructions in the Winch Owner's Manual.
 - OPERATORS must be in good health, alert, thoroughly trained in operating the equipment, and properly clothed (hard hat, safety shoes and safety glasses, no loose clothing, etc).
 - THE LOAD must be clear of other objects and free to move. Make sure the load will not tip, spin, roll away, or in any way move uncontrollably.
- 2.2.3 KNOW YOUR LOAD and make sure you do not exceed the load rating of the crane or any other equipment in the system.
- 2.2.4 POSITION THE BOOM so the load hook is centered over the load. **Avoid side pulls which could damage the crane or cause the load to tip. See Figure 7.**
- ADJUST SHEAVE POSITION by moving the sheave assembly up or down the boom. Do not make adjustments while the crane is loaded. **The load rating decreases as you increase sheave distance from mast. See the Performance Characteristics Tables pages 22-23.**
 - ADJUST BOOM ANGLE by rotating the boom adjustment brace knob to raise or lower the boom. Do not make adjustments while the crane is loaded. The lift height below base level decreases as you raise the boom. **See the Performance Characteristics Tables pages 22-23.**

2.3 Attaching the Load

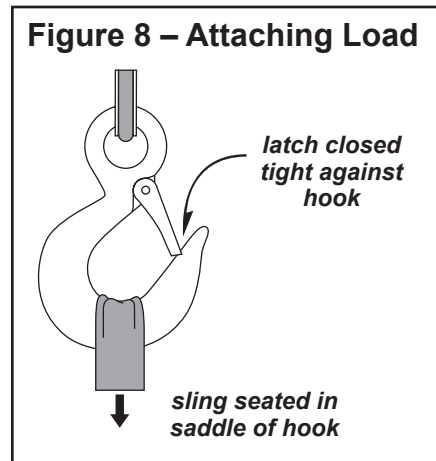

⚠WARNING

Do not wrap the wire rope around the load. This damages the wire rope and could cause the load to escape. Use a sling or other approved lifting device.

- 2.3.1 CLEAR OBJECTS from the path of the load so you can move it freely and observe it at all times during the operation.
- 2.3.2 MAKE SURE THE WIRE ROPE is not twisted. A twisted wire rope could cause the load to spin when it is raised off the ground.
- 2.3.3 ATTACH THE LOAD using a nylon sling, or other approved lifting device. Follow the recommendations of the sling manufacturer.
 - a SEAT THE SLING in the saddle of the hook with the hook latch completely closed. See Figure 8.
 - b CENTER THE LOAD on the hook so it will remain balanced and not tip or rotate to one side.

2.4 Moving the Load

Important!

- Obey a stop signal from anyone.
- Maintain tension on the wire rope to keep it tightly and evenly wound on the drum.
- If the crane and load are not visible during the entire operation, get help from another person.
- Appoint a supervisor if more than one person is involved in the operation. This will reduce confusion and increase safety.
- When lifting a load, use a tag line to keep the load from swinging or twisting, while keeping yourself away from the load.

- 2.4.1 MOVE THE LOAD slowly and smoothly, only a small distance at first. Make sure the load is balanced and securely attached before continuing.
- 2.4.2 OPERATE THE WINCH to raise or lower the load. Refer to the instructions in the Winch Owner's Manual.
- 2.4.3 OBSERVE THE WIRE ROPE as it winds onto the drum. If it becomes loose, uneven, or overlapped, stop the operation and rewind the wire rope before continuing. **Continued operation with overlapped or uneven wire rope can damage the wire rope and shorten its life.**
- 2.4.4 ADJUST THE BOOM ANGLE, if necessary, to keep the sheave centered over the load. Do not make adjustments while the crane is heavily loaded.
- 2.4.5 ROTATE THE BOOM to move the load side-to-side.
 - a ROTATE THE BOOM slowly and smoothly to avoid swinging the load or causing shock loads. **Do not jam the boom against other objects.**
 - b USE THE HANDLE to rotate the boom. **Do not push or pull the load or the wire rope to rotate the boom.**

3.1 Cleaning the Crane

Important!

Increase the frequency of maintenance procedures if the crane is:

- Operated for long periods.
- Used to lift heavy loads.
- Operated in wet, dirty, hot, or cold surroundings.

Clean the crane to remove dirt and help prevent rust and corrosion.

- 3.1.1 CLEAN THE CRANE every six months or whenever it is dirty.
- a WIPE ALL EQUIPMENT to remove dirt and grease.
 - b LEAVE A LIGHT FILM of oil on all surfaces to protect against rust and corrosion.
 - c WIPE OFF excessive amounts of oil to avoid the accumulation of dirt.
- 3.1.2 REMOVE UNNECESSARY OBJECTS from the area surrounding the crane.

3.2 Lubricating the Crane

Important!

- Make sure lubricant has a temperature rating appropriate for the ambient temperatures of the operation.

Lubricate the crane properly to help protect it from wear and rust. Read the following instructions carefully.

- 3.2.1 LUBRICATE ALL PINS before installation and at least every 3 months. Use a grease brush to apply a light film of NLGI #2 grease to all pins.
- 3.2.2 LUBRICATE THE BASE PIN located at the bottom of the base before installation and at least every 3 months. Use a grease brush to apply a film of NLGI #2 grease to the pin. **Not required with 5PA5 model.**
- 3.2.3 LUBRICATE THE MAST BEARING located on top of the base before installation and at least every 3 months. Use a grease gun to apply NLGI #2 grease to the grease fitting on the bearing. **Not required with 5PA5 model.**
- 3.2.4 LUBRICATE THE BOOM ADJUSTMENT SCREW before installation and at least every 3 months. Apply a light film of anti-seize compound to the screw threads. Wipe away any excess lubricant.
- 3.2.5 LUBRICATE THE WINCH. Refer to the Winch Owner's Manual for instructions.
- 3.2.6 LUBRICATE THE WIRE ROPE and other equipment by following the manufacturers recommendations.

3.3 Disassembling the Crane

⚠CAUTION

When removing the boom brace assembly, carefully support the boom so that it does not fall abruptly causing damage or injury.

- 3.3.1 STUDY PARTS DRAWINGS to understand how the crane is assembled. See pages 18-21.
- 3.3.2 REMOVE ANY ATTACHED LOAD from the wire rope.
- 3.3.3 LOWER THE BOOM by removing the boom brace assembly. Carefully support the boom so that it does not fall abruptly causing damage or injury.
 - a IN SOME SITUATIONS it may be desirable to use the winch to lower the boom. Secure the load hook at the rear of the boom as shown in Figure 6. The wire rope must be installed correctly to prevent damage to the rope. Once the boom brace assembly is removed, and the boom safely lowered, remove the load hook from the rear of the boom.
- 3.3.4 REMOVE THE WIRE ROPE.
 - a REMOVE ROPE KEEPER PINS located at each sheave near the ends of the boom.
 - b UNWIND THE ROPE from the winch drum and release the anchor.
 - c REPLACE THE ROPE KEEPER PINS
- 3.3.5 REMOVE THE WINCH HANDLE on hand winches, or disconnect electric current on power winches. Refer to instructions in the Winch Owner's Manual.
- 3.3.6 REMOVE THE SHEAVE ASSEMBLY from the boom. Replace the attachment clevis pin back in the sheave assembly to prevent loss.
- 3.3.7 DISCONNECT THE BOOM from the mast.
 - a SECURE THE BOOM to prevent it from falling when the clevis pin is removed.
 - b REMOVE THE CLEVIS PIN and carefully remove the boom.
 - c REPLACE the clevis pin to prevent loss.
- 3.3.8 REMOVE THE WINCH and mounting bracket from the mast. Replace the clevis pin to prevent loss.
- 3.3.9 REMOVE THE ROTATION HANDLE from the mast. Replace the clevis pin to prevent loss.
- 3.3.10 REMOVE THE MAST from the base by lifting it straight out of the base.
- 3.3.11 REMOVE THE BEARING from the base. Install a cap over the base to prevent debris and other contaminants from getting into the base.

3.4 Inspecting the Equipment

Important!

- Start an inspection program as soon as you put the crane into use.
- Appoint a qualified person to be responsible for regularly inspecting the equipment.
- Keep written records of inspection. This allows comparison with comments from previous inspections so you can see changes in condition or performance.

Perform frequent inspections:

- Before each operation.
- Every 3 hours during operation.
- Whenever you notice signs of damage or poor operation.

Frequent Wire Rope Inspection:

- Use ASME B30.7 as a guideline for rope inspection, replacement and maintenance.
- Check the wire rope, end connections and end fittings for corrosion, kinking, bending, crushing, bird-caging or other signs of damage.
- Check the number, distribution and type of visible broken wires. See paragraph 3.4.4 b and Figure 9.
- Check the wire rope for reduction of rope diameter from loss of core support, or wear of outside wires. See Figure 11.
- Take extra care when inspecting sections of rapid deterioration such as sections in contact with saddles, sheaves, repetitive pickup points, crossover points and end connections.

⚠WARNING

Do not use damaged or malfunctioning equipment. Place an “OUT OF ORDER” sign on the crane. Do not use the crane until the sign is removed by a qualified person who has completely corrected the problem.

Inspect the crane to detect signs of damage or poor operation before they become hazardous. See Table 2 - Inspection Checklist.

3.4.1 CONSULT APPLICABLE CODES AND REGULATIONS for specific rules on inspecting the crane and other equipment.

3.4.2 REFER TO THE WINCH OWNER’S MANUAL for information regarding winch inspection.

3.4.3 Instructions for Frequent Inspection

a VISUALLY INSPECT the entire crane and all other equipment involved in the operation.

- Check all equipment for cracks, dents, bending, rust, wear, corrosion and other damage.
- Make sure the wire rope is installed correctly and anchored securely.
- Make sure the entire crane is properly lubricated.
- Make sure all fasteners are tight and secure.
- Make sure mounting fasteners are tightened securely.
- Check the boom brace assembly for signs of damage, and make sure it operates smoothly to raise and lower the boom.
- Make sure the foundation is in good condition, and capable of supporting the crane and its load under all load conditions.

b TEST CRANE PERFORMANCE by operating the crane with a load not exceeding the load rating.

- Listen for unusual noises, and look for signs of damage as you operate the crane.
- Make sure the wire rope winds evenly and tightly onto the drum. If it is loose or uneven, rewind it before continuing.
- Make sure the load moves smoothly, without hesitation or strain.
- On hand operated models, make sure the winch handle rotates freely in both directions.
- On power operated models, make sure the winch responds to the control device. It must rotate as shown on the control labels, and it must turn off when you release the control.
- Make sure the boom rotates freely when you push the handle, and remains stationary when you release it.
- Check the winch brake. Raise the load, then lower it and stop it a few feet off the ground. If the load continues to coast or creep under normal operating conditions, the brake may be worn and in need of repair or replacement. Contact the factory.

Completely correct all problems before continuing. Use the Troubleshooting Chart to help determine the cause of certain problems. See Table 3.

Perform periodic inspections:

- Every 6 months.
- Whenever you return the crane to service from storage.
- Whenever you notice damage or poor operation in a frequent inspection.
- Whenever you have, or think you may have, overloaded or shock loaded the crane.

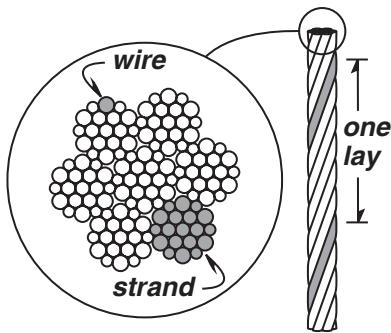
Figure 9 – Broken Wires

Wire rope assembly must be replaced if more than 6 wires are broken in one lay, or if more than 3 wires are broken in one strand in one lay.

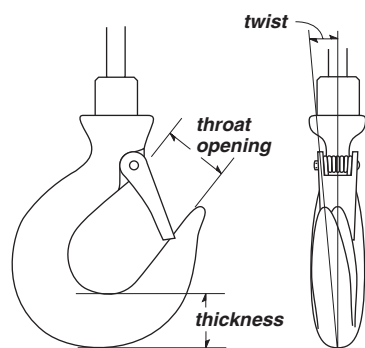
Figure 10 – Load Hook Inspection

The wire rope assembly must be replaced if the throat opening is 15% wider than nominal, if the thickness is 10% less than nominal, or if the hook is twisted 10° or more.

3.4.4 Instructions for Periodic Inspection

- a VISUALLY INSPECT the crane and all other equipment.
 - Check the finish for wear, flaking, or other damage.
 - Check all equipment for cracks, dents, bending, rust, wear, corrosion and other damage. If the equipment was overloaded, or if you notice cracks and other signs of overloading and damage, promptly remove equipment from use and have it repaired or replaced. **DO NOT CONTINUE TO USE DAMAGED OR OVERLOADED EQUIPMENT OR WIRE ROPE.**
 - Check all fasteners for stripped threads, wear, bending, and other damage.
 - Make sure the entire crane is properly lubricated.
 - Check the boom brace assembly for signs of damage, and make sure it operates smoothly to raise and lower the boom.
 - Make sure all labels and plates are readable, firmly attached, free of damage and clean. Replacements are available from the factory.
- b INSPECT THE WIRE ROPE according to the wire rope manufacturer's recommendations, or follow accepted industry standards for wire rope inspection.
 - Always wear protective clothing when handling wire rope.
 - Check the entire length of wire rope for bent wires, crushed areas, broken or cut wires, corrosion, and other damage. Carefully inspect areas that pass over sheaves or through roller guides.
 - Note the location and concentration of broken wires. Replace wire rope if more than 6 wires are broken in one lay, or more than 3 wires are broken in one strand in one lay. See Figure 9.
 - Make sure the load hook or other device is securely attached to the wire rope, and the wire rope where it is attached is not frayed, corroded, broken, or otherwise damaged.
 - Measure the throat opening, thickness, and twist of the hook. Replace the hook if it shows signs of damage. See Figure 10.
 - Make sure hook latch opens without binding and closes when released.
 - Check the anchor holes in the drum and the surrounding area for signs of wear or distortion.
- c PLACE enough weight to keep the wire rope straight and tightly drawn.
 - Measure the diameter of the wire rope, especially in areas where wear is noticeable. Replace the wire rope if the diameter measures below the minimum diameter at any point. See Figure 11.
- d REMOVE THE WINCH and inspect it by following the instructions in the Winch Owner's Manual.
- e DISASSEMBLE THE CRANE.
 - Inspect each component for damage.
- f REMOVE THE CRANE BASE from the foundation.
 - Check fasteners for stripped threads, wear, bending, and other damage.
 - Check the foundation for cracks, corrosion, and other damage.

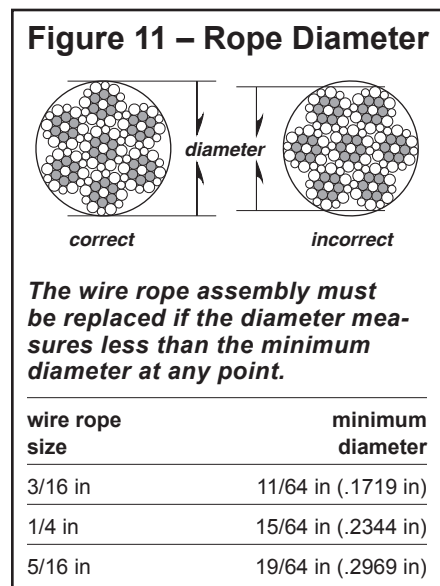

- g FASTEN THE CRANE BASE securely to the foundation.
- h REASSEMBLE THE CRANE.
- i TEST CRANE PERFORMANCE by operating the crane with a load not exceeding the load rating.
 - Listen for unusual noises, and look for signs of damage as you operate the crane.
 - Make sure the wire rope winds evenly and tightly onto the drum. If it is loose or uneven, rewind it before continuing.
 - Make sure the load moves smoothly, without hesitation or strain.
 - On hand operated models, make sure the winch handle rotates freely in both directions.
 - On power operated models, make sure the winch responds to the control device. It must rotate as shown on the control labels, and it must turn off when you release the control.
 - Make sure the boom rotates freely when you push the handle, and remains stationary when you release it.
 - Check the brake. Raise the load, then lower it and stop it a few feet off the ground. If the load continues to coast or creep under normal operating conditions, the brake may be worn and in need of repair or replacement. Contact the factory.

Completely correct all problems before continuing. Use the Troubleshooting Chart to help determine the cause of certain problems. See Table 3.

problem	cause	correction
overheating	<ul style="list-style-type: none"> • operated too long without rest. • load too heavy • poor lubrication. • bearing seized up 	<ul style="list-style-type: none"> allow to cool lighten load inspect and lubricate as necessary inspect and replace as necessary
boom bounces up and down	<ul style="list-style-type: none"> • load too heavy • mounting bolts loose • sheave worn or damaged. • foundation loose or unlevel • winch gears worn or damaged 	<ul style="list-style-type: none"> lighten load tighten mounting bolts to proper torque inspect and replace as necessary inspect and repair as necessary inspect and repair as necessary
boom does not rotate	<ul style="list-style-type: none"> • rotation points contaminated or worn • flange bearing broken or locked. 	<ul style="list-style-type: none"> inspect and repair as necessary inspect and replace as necessary
boom rotates on its own	<ul style="list-style-type: none"> • foundation loose or unlevel • mast bent, distorted, or leaning. 	<ul style="list-style-type: none"> inspect and repair as necessary inspect and repair as necessary
unusual noises		
high pitched squeak	<ul style="list-style-type: none"> • poor lubrication. 	<ul style="list-style-type: none"> lubricate entire crane properly
grinding noise	<ul style="list-style-type: none"> • contaminated lubricant at rotation points 	<ul style="list-style-type: none"> clean and lubricate rotation points
rattling noise	<ul style="list-style-type: none"> • loose bolts, set screws or other fasteners. 	<ul style="list-style-type: none"> tighten all bolts and other fasteners
Refer to the Winch Owner's Manual for possible problems with the winch and brake.		

3.5 Repairing the Crane

Important!

- It is your responsibility to determine when to replace parts. When considering whether to continue using a part or to replace it, remember that replacing it is the best way to avoid further equipment damage.
- Appoint a qualified person to be responsible for all repairs to the equipment.

- 3.5.1 GET FACTORY AUTHORIZATION for all repairs. Unauthorized repairs will void the warranty, and may lead to damage or failure of the crane.
- 3.5.2 REPLACE DAMAGED OR POORLY OPERATING PARTS with Thern repair parts.
- 3.5.3 REFINISH AREAS where the paint is worn or flaking. A good finish helps to protect against corrosion and weather damage.
- REMOVE THE FINISH from damaged areas, down to the bare metal.
 - CLEAN THE AREA thoroughly.
 - REPAINT with a high quality primer and finishing coat.
- 3.5.4 TO ORDER REPAIR PARTS, contact your local dealer. Include the following information when ordering:
- model number
 - serial number (or code number)
 - part number
 - date purchased, and from whom
 - description of what happened, or what is wrong
 - your name and return address

Table 4 – Component Weight Chart

	Model 5PA5		Model 5PA10	
	LB	KG	LB	KG
Mast Assembly	21	9.5	52	23.6
Boom Assembly	29	13.1	53	24.0
Boom Brace Assembly	4	1.8	7	3.2
Sheave Assembly	5	2.3	6	2.7
Handle	2	0.9	2	0.9
Bearing Assembly	-	-	9	4.1
TOTAL	61	27.6	129	58.5
Winch (including bracket)	LB	KG	LB	KG
M1 (M4022PB-K)	19	8.6	-	-
M3 (M4042PBSS-K)	26	11.8	-	-
M1 (M4312PB-K)	-	-	32	14.5
M3 (M4312PBSS-K)	-	-	32	14.5
M2 (4WM2V-K)	40	18.1	42	19.0
E2 (4WP2-K)	74	33.6	76	34.5
E4 (4777-K)	96	43.6	98	44.5
E4DC (4777DC-K)	120	54.5	122	55.3

Important!

- Keep a record of what you ship, and when you send it.

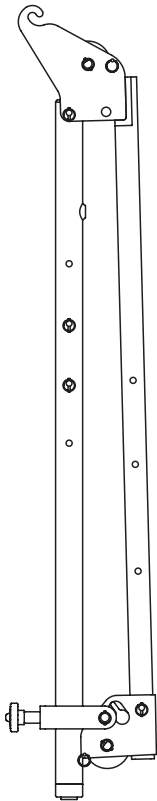
Figure 12 – Packing the Crane

CONFIGURATION
WITH MAST AND
BOOM SECURED.

4.1 Transporting the Crane

- 4.1.1 PARTIALLY DISASSEMBLE THE CRANE into components that can be transported. Figure 12 shows a configuration with the mast and boom secured together.
- 4.1.2 PACK THE CRANE for transport, using the original packaging materials, if appropriate.
- 4.1.3 PACK THE WINCH for transport, using the original packaging materials, if appropriate. Please see the winch owner's manual for instructions.
- 4.1.4 REASSEMBLE THE CRANE at its new location following the instructions under Section 1.2 - Assembling the Crane.
- 4.1.5 INSPECT THE CRANE according to the Instructions for Frequent Inspection before installing it for operation. See Section 3.4.3 - Instructions for Frequent Inspection.

4.2 Storing the Crane

- 4.2.1 PARTIALLY DISASSEMBLE THE CRANE and store all parts in a cool clean place away from corrosive chemicals and moisture.
- 4.2.2 SEAL THE CRANE in plastic with a desiccant to help protect it from rust, corrosion, and other damage.
- 4.2.3 SEAL THE WINCH in plastic with a desiccant to help protect it from rust, corrosion, and other damage. Please see the winch owner's manual for instructions.
- 4.2.4 REASSEMBLE THE CRANE at its new location according to Section 1.2 - Assembling the Crane.
- 4.2.5 INSPECT THE CRANE according to Section 3.4.4 - Instructions for Periodic Inspection before installing it for operation.

5PA5 Series Portable Davit Cranes

item	description	part number	qty.	material
1	BEARING ASSY 5PA5	B7468	1	
2	WELDMENT MAST 5PA5	B5829	1	SEE TABLE
3	BRACKET SHEAVE 5PA5	C4826	1	SEE TABLE
4	WELDMENT BOOM 5PA5	C4831	1	SEE TABLE
5	HANDLE ROTATION 5PA5	B5825	1	SEE TABLE
6	BOOM BRACE ASSY 5PA5	B5827	1	SEE TABLE
7	WELDMENT WINCH MOUNT 5PA5	C4828	1	SEE TABLE
8	FLANGE BEARING	B5811	1	
9	SHEAVE ASSEMBLY	B2462	2	
10	PIN HEADLESS .750 X 2.625 EFF LENGTH SST	A11538	1	
11	PIN HEADLESS .750 X 3.000 EFF LENGTH SST	A11539	1	
12	PIN HEADLESS .750 X 3.500 EFF LENGTH SST	A11540	1	
13	PIN HEADLESS .500 X 2.625 EFF LENGTH SST	A11541	1	
14	PIN HEADLESS .500 X 3.000 EFF LENGTH SST	A11542	2	
15	PIN HEADLESS .500 X 4.000 EFF LENGTH SST	A11543	1	
16	PIN QUICK RELEASE .188 X .800 SST SEE SPEC	A11534	5	
17	PIN QUICK RELEASE ASSY 5PA SST	A11535	1	
18	PIN QUICK RELEASE ASSY 5PA5	A13556	1	SEE TABLE
19	PLUG FINISH RND 2.250 X 10-14GA BLK	A11560	1	
20	LABEL NAMEPLATE CRANES CE	A11529	1	
21	LABEL NAMEPLATE THERN LOGO	A6889	2	
22	LABEL WARNING	B5790	1	
23	LABEL WARNING BEFORE LOADING	B5791	2	
24	LABEL LOAD RATING 5PA5	B5792	1	
25	LABEL MODEL ENSIGN	B6111	2	

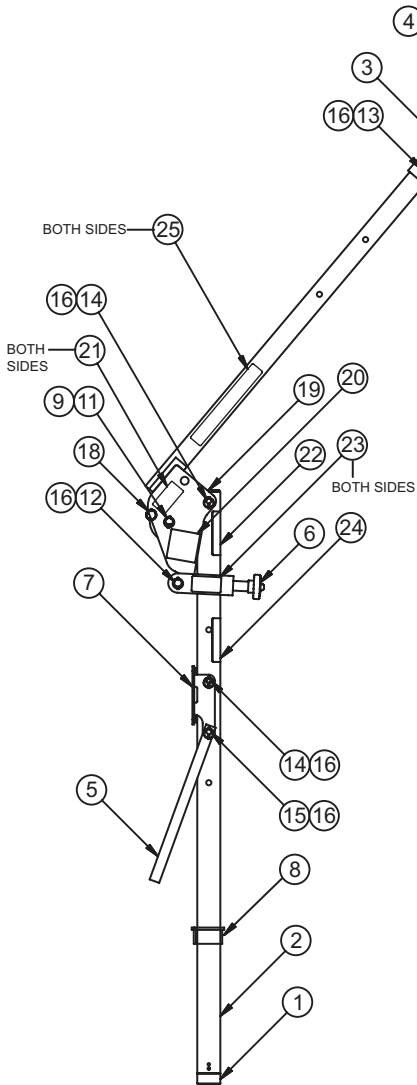

	5PA5 Fusibond	5PA5G Galvanized	5PA5X Epoxy	5PA5S Stainless	5PA5S316 Stainless316
item	B5829 RED	B5829 GAL	B5829 EGRA	B5829 SS	B5829 SS316
3	C4826 RED	C4826 GAL	C4825 EGRA	C4826 SS	C4826 SS316
4	C4831 RED	C4831 GAL	C4831 EGRA	C4831 SS	C4831 SS316
5	B5825 RED	B5825 GAL	B5825 EGRA	B5825 SS	B5825 SS316
6	B5827 RED	B5827 GAL	B5827 EGRA	B5827 SS	B5827 SS316
7	C4828 RED	C4828 GAL	C4828 EGRA	C4828 SS	C4828 SS316
18	A13556	A13556	A13556 SS	A13556 SS	A13556 SS

Use component part numbers for material / finish that matches crane model number.

Example: Crane model 5PA5G uses components with part numbers XXXXXGAL.

5PA5 Series	-M1	-M2	-M2X	-M3
description	part number	part number	part number	part number
MANUAL WINCH	M4022PB-K	4WM2V-K	4WM2VEGRA-K	M4042PBSS-K
description	part number	part number	part number	
ELECTRIC WINCH	4WP2V-K	4777-K	4777DC-K	
ADAPTER PLATE		C3114	C5137	
description	part number	part number	part number	
ELECTRIC WINCH	4WP2VEGRA-K	4777EGRA-K	4777DCEGRA-K	
ADAPTER PLATE		C3114EGRA	C5137EGRA	

5PA10 Series Portable Davit Cranes

item	description	part number	qty.	material
1	WELDMENT MAST 5PA10	B6100	1	SEE TABLE
2	BRACKET SHEAVE 5PA10	D3964	1	SEE TABLE
3	WELDMENT BOOM 5PA10	C4975	1	SEE TABLE
4	HANDLE ROTATION 5PA10	B6096	1	SEE TABLE
5	BOOM BRACE ASSY 5PA10	B6108	1	SEE TABLE
6	WELDMENT WINCH MOUNT 5PA10	C4976	1	SEE TABLE
7	BEARING ASSY 3.50 DIA MAST	B6235	1	SEE TABLE
8	ROTATION LOCK ASSEMBLY 5Px	B6241	1	SEE TABLE
9	SHEAVE ASSEMBLY	B2462	2	
10	PIN HEADLESS .750 X 2.625 EFF LENGTH SST	A11538	1	
11	PIN HEADLESS .750 X 4.062 EFF LENGTH SST	A12171	1	
12	PIN HEADLESS .750 X 4.688 EFF LENGTH SST	A12172	1	
13	PIN HEADLESS .750 X 2.625 EFF LENGTH SST	A12173	1	
14	PIN HEADLESS .750 X 4.188 EFF LENGTH SST	A12174	1	
15	PIN HEADLESS .750 X 5.250 EFF LENGTH SST	A12175	1	
16	PIN QUICK RELEASE .188 X .800 SST SEE SPEC	A11534	5	
17	PIN QUICK RELEASE ASSY 5PA SST	A11535	1	
18	PIN QUICK RELEASE ASSY 5PA10	A12126	1	SEE TABLE
19	PLUG FINISH RND 3.000 X SCH40-160 RED	A13550	1	
20	PIN HEADLESS .375 X 2.500 EFF LENGTH SST	A12196	1	
21	RING RET EXT .375 SST	A6321	2	
22	LABEL NAMEPLATE CRANES CE	A11529	1	
23	LABEL THERN 1.00 X 3.20	A6889	2	
24	LABEL WARNING	B5790	1	
25	LABEL WARNING BEFORE LOADING	B5791	2	
26	LABEL LOAD RATING 5PA10	B6110	1	
27	LABEL MODEL ENSIGN	B6111	2	

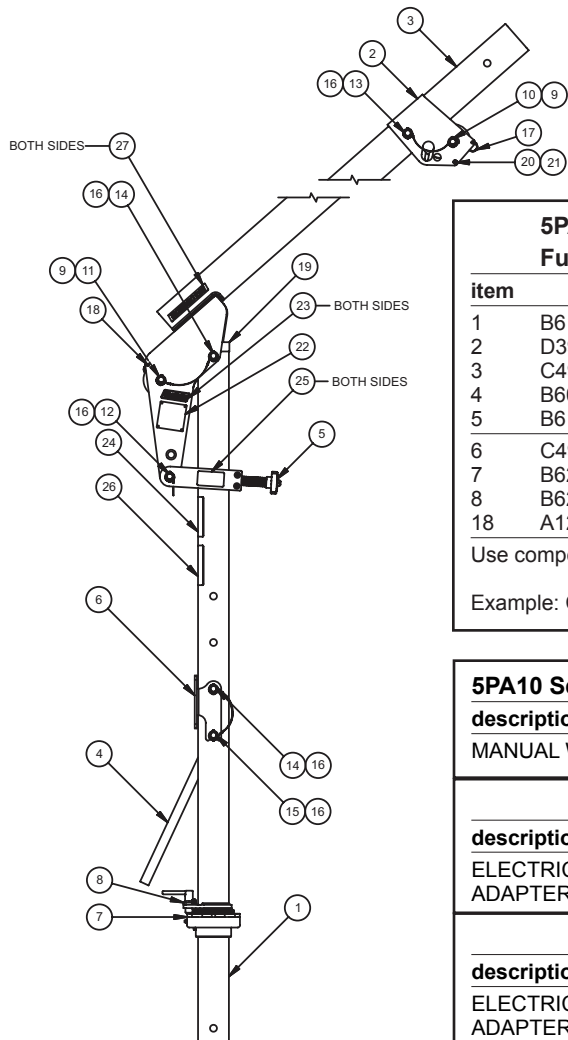

	5PA10	5PA10G	5PA10X	5PA10S	5PA10S316
	Fusibond	Galvanized	Epoxy	Stainless	Stainless316
item					
1	B6100 RED	B6100 GAL	B6100 EGRA	B6100 SS	B6100 SS316
2	D3964 RED	D3964 GAL	D3964 EGRA	D3964 SS	D3964 SS316
3	C4975 RED	C4975 GAL	C4975 EGRA	C4975 SS	C4975 SS316
4	B6096 RED	B6096 GAL	B6096 EGRA	B6096 SS	B6096 SS316
5	B6108 RED	B6108 GAL	B6108 EGRA	B6108 SS	B6108 SS316
6	C4976 RED	C4976 GAL	C4976 EGRA	C4976 SS	C4976 SS316
7	B6235 RED	B6235 GAL	B6235 EGRA	B6235 SS	B6235 SS316
8	B6241 SS	B6241 SS	B6241 SS	B6241 SS	B6241 SS316
18	A12126	A12126	A12126 SS	A12126 SS	A12126 SS

Use component part numbers for material / finish that matches crane model number.

Example: Crane model 5PA10G uses components with part numbers XXXXXGAL.

5PA10 Series	-M1	-M2	-M2X	-M3
description	part number	part number	part number	part number
MANUAL WINCH	M4312PB-K	4WM2V-K	4WM2VEGRA-K	M4312PBSS-K
description	part number	part number	part number	part number
ELECTRIC WINCH	4WP2V-K	4777-K	4777DC-K	
ADAPTER PLATE		C3114	C5137	
description	part number	part number	part number	part number
ELECTRIC WINCH	4WP2VEGRA-K	4777EGRA-K	4777DCEGRA-K	
ADAPTER PLATE		C3114EGRA	C5137EGRA	

Pedestal Base

5BP5 Series

item	part no.	description
1	SEE TABLE	WELDMENT BASE 5BP5
2	5BC5	BASE COVER W/LANYARD
3	A14588	LABEL THERN
4	A14615	RETAINER PUSH

¹ When ordering parts, be sure to specify whether the finish is red, galvanized, epoxy or stainless.

	5BP5	5BP5G	5BP5X	5BP5S	5BP5S316
item					
1	B5821 RED	B5821 GAL	B5821 EGRA	B5821 SS	B5821 SS316

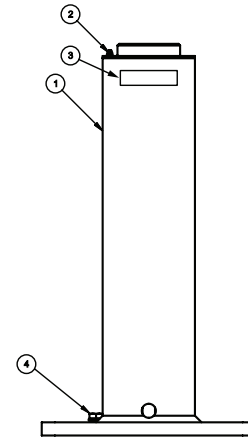

**5BP5
Pedestal Base**

Wall Base

5BW5 Series

item	part no.	description
1	SEE TABLE	WELDMENT BASE 5BW5
2	5BC5	BASE COVER W/LANYARD
3	A14588	LABEL THERN
4	A14615	RETAINER PUSH

¹ When ordering parts, be sure to specify whether the finish is red, galvanized, epoxy or stainless.

	5BW5	5BW5G	5BW5X	5BW5S	5BW5S316
item					
1	B5819 RED	B5819 GAL	B5819 EGRA	B5819 SS	B5819 SS316

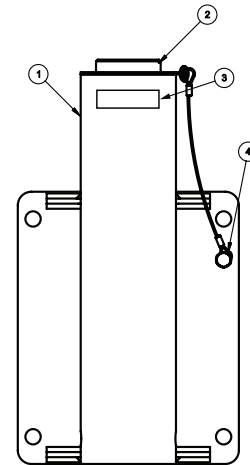

**5BW5
Wall Base**

Flush Base

5BF5 Series

item	part no.	description
1	SEE TABLE	WELDMENT BASE 5BF5
2	5BC5	BASE COVER W/LANYARD
3	A14588	LABEL THERN
4	A14615	RETAINER PUSH

¹ When ordering parts, be sure to specify whether the finish is red, galvanized, epoxy or stainless.

	5BF5	5BF5G	5BF5X	5BF5S	5BF5S316
item					
1	B5820 RED	B5820 GAL	B5820 EGRA	B5820 SS	B5820 SS316

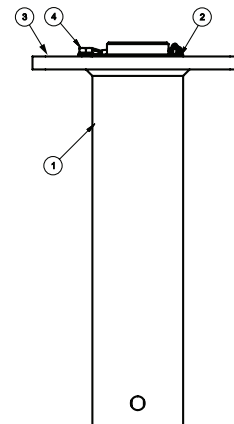

**5BF5
Flush Base**

Pedestal Base		
5BP10 Series		
item	part no.	description
1	SEE TABLE	WELDMNT BASE 5BP10
2	SBC10	BASE COVER W/LANYARD
3	A14588	LABEL THERN
4	A14615	RETAINER PUSH
5	A4379	NUT HEX JAM NYLK .312-18NC SST 18-8
6	A13820	CAPSCR SOKLHD .312-18NC X .500 ZNPL

¹ When ordering parts, be sure to specify whether the finish is red, galvanized, epoxy or stainless.

	5BP10	5BP10G	5BP10X	5BP10S	5BP10S316
item					
1	B6181 RED	B6181 GAL	B6181 EGRA	B6181 SS	B6181 SS316

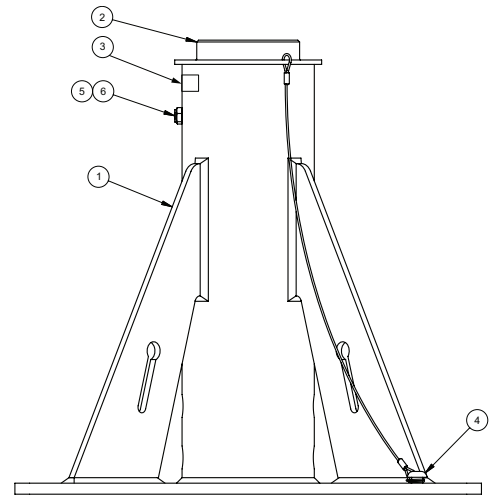

**5BP10
Pedestal Base**

Wall Base		
5BW10 Series		
item	part no.	description
1	SEE TABLE	WELDMNT BASE 5BW10
2	SBC10	BASE COVER W/LANYARD
3	A14588	LABEL THERN
4	A14615	RETAINER PUSH
5	A13820	CAPSCR SOKLHD .312-18NC X .500 ZNPL
6	A4379	NUT HEX JAM NYLK .312-18NC SST 18-8

¹ When ordering parts, be sure to specify whether the finish is red, galvanized, epoxy or stainless.

	5BW10	5BW10G	5BW10X	5BW10S	5BW10S316
item					
1	B6179 RED	B6179 GAL	B6179 EGRA	B6179 SS	B6179 SS316

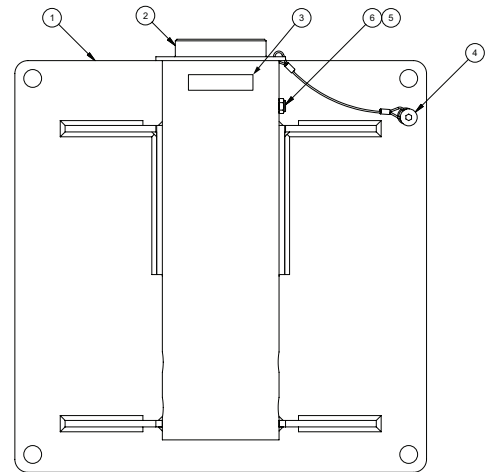

**5BW10
Wall Base**

Flush Base		
5BF10 Series		
item	part no.	description
1	SEE TABLE	WELDMNT BASE 5BF10
2	SBC10	BASE COVER W/LANYARD
3	A14588	LABEL THERN
4	A14615	RETAINER PUSH
5	A13820	CAPSCR SOKLHD .312-18NC X .500 ZNPL
6	A4379	NUT HEX JAM NYLK .312-18NC SST 18-8

¹ When ordering parts, be sure to specify whether the finish is red, galvanized, epoxy or stainless.

	5BF10	5BF10G	5BF10X	5BF10S	5BF10S316
item					
1	B6180 RED	B6180 GAL	B6180 EGRA	B6180 SS	B6180 SS316

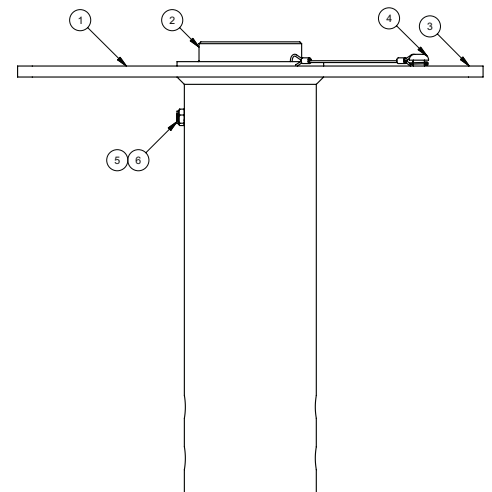

**5BF10
Flush Base**

5PA5 Series Lift Below Floor²

Lift Below ¹ Floor				Wire Rope Diameter		Wire Rope Length		Winch Configurations				
Minimum (B4)		Maximum (B1)						M1	M2	M3	E2	E4
(ft)	(m)	(ft)	(m)	(in)	(mm)	(ft)	(m)					
0	0	5	1.5	3/16	5	20	6.0	x	-	x	-	x
8	2.4	13	3.9	3/16	5	28	8.5	x	-	x	-	x
16	4.8	21	6.4	3/16	5	36	10.9	x	-	x	-	x
25	7.6	30	9.1	3/16	5	45	13.7	x	-	x	-	x
40	12.1	45	13.7	3/16	5	60	18.2	-	-	x	-	x
55	16.7	60	18.2	3/16	5	75	22.8	-	-	x	-	x
70	21.3	75	22.8	3/16	5	90	27.4	-	-	-	-	x
0	0	5	1.5	1/4	6	20	6.0	-	x	x	x	x
8	2.4	13	3.9	1/4	6	28	8.5	-	x	x	x	x
16	4.8	21	6.4	1/4	6	36	10.9	-	x	x	x	x
25	7.6	30	9.1	1/4	6	45	13.7	-	x	x	x	x
40	12.1	45	13.7	1/4	6	60	18.2	-	-	-	-	x

5PA5 Performance Ratings²

Boom Position	Load Rating		Hook Reach		Hook Height	
	(lb)	(kg)	(in)	(mm)	(in)	(mm)
A-1	500	226	17	431	74	1879
A-2	400	181	22	558	79	2006
A-3	300	136	28	711	87	2209
A-4	250	113	36	914	96	2438
B-1	500	226	14	355	76	1930
B-2	400	181	17	431	83	2108
B-3	300	136	22	558	91	2311
B-4	250	113	28	711	101	2565

¹ Lift below floor level varies depending on boom position and base configuration. For longer lifts, please contact factory.

² Performance Characteristics are for standard products referred to in this manual. Non-standard products may vary from the original design. Contact Thern, Inc. for this information.

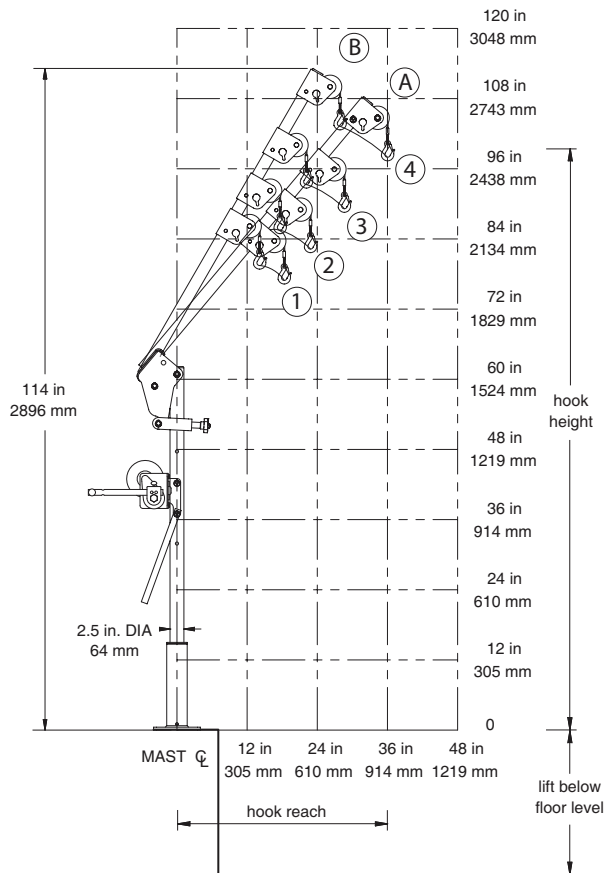

IMPORTANT:

It is the owner or operator's responsibility to determine the suitability of the equipment to its intended use. Study all applicable codes, manuals and regulations. Be sure to read the Owner's Manual supplied with the equipment before operating it.

5PA10 Series Lift Below Floor²

Lift Below ¹ Floor				Wire Rope Diameter		Wire Rope Length		Winch Configurations				
Minimum (B4)		Maximum (B1)						M1	M2	M3	E2	E4
(ft)	(m)	(ft)	(m)	(in)	(mm)	(ft)	(m)					
5	1.5	9	2.7	3/16	5	28	8.5	x	-	x	-	x
13	3.9	17	5.1	3/16	5	36	10.9	x	-	x	-	x
22	6.7	26	7.9	3/16	5	45	13.7	x	-	x	-	x
37	11.2	41	12.4	3/16	5	60	18.2	x	-	x	-	x
52	15.8	56	17.0	3/16	5	75	22.8	x	-	x	-	x
67	20.4	71	21.6	3/16	5	90	27.4	x	-	x	-	x
5	1.5	9	2.7	1/4	6	28	8.5	x	x	x	x	x
13	3.9	17	5.1	1/4	6	36	10.9	x	x	x	x	x
22	6.7	26	7.9	1/4	6	45	13.7	x	x	x	x	x
37	11.2	41	12.4	1/4	6	60	18.2	-	x	-	x	x
5	1.5	9	2.7	5/16	8	28	8.5	x	-	x	-	x
13	3.9	17	5.1	5/16	8	36	10.9	x	-	x	-	x
22	6.7	26	7.9	5/16	8	45	13.7	-	-	-	-	x

5PA10 Performance Ratings²

Boom Position	Load Rating		Hook Reach		Hook Height	
	(lb)	(kg)	(in)	(mm)	(in)	(mm)
A-1	1200	544	26	660	93	2362
A-2	1000	453	32	812	98	2489
A-3	800	362	39	990	104	2641
A-4	650	294	48	1219	112	2844
B-1	1200	544	22	558	97	2463
B-2	1000	453	26	660	103	2616
B-3	800	326	32	812	110	2794
B-4	650	294	39	990	120	3048

¹ Lift below floor level varies depending on boom position and base configuration. For longer lifts, please contact factory.

² Performance Characteristics are for standard products referred to in this manual. Non-standard products may vary from the original design. Contact Thern, Inc. for this information.

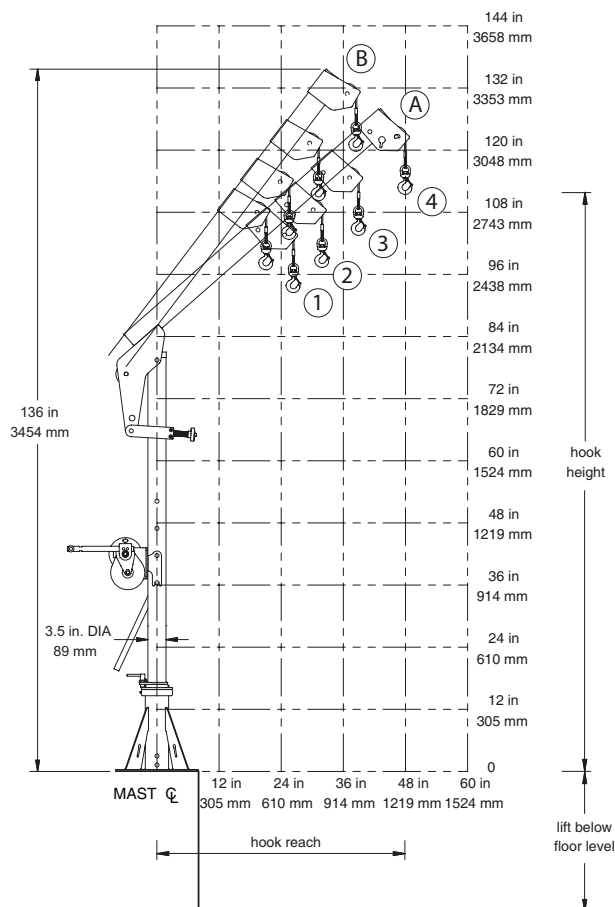

IMPORTANT:

It is the owner or operator's responsibility to determine the suitability of the equipment to its intended use. Study all applicable codes, manuals and regulations. Be sure to read the Owner's Manual supplied with the equipment before operating it.



Thern, Incorporated
5712 Industrial Park Road
Winona, MN 55987

PH: 507-454-2996
FAX: 507-454-5282

EMAIL: info@thern.com
www.thern.com

Thern Europe
Siriusdreef 17-27, 2132 WT
Hoofddorp
The Netherlands

PH: +31-546-898-380

EMAIL: europe@thern.com