



Read this Owner's Manual thoroughly before operating the equipment. Keep it with the equipment at all times. Replacements are available from Thern, Inc., Winona, MN 55987, 507-454-2996. www.thern.com

IMPORTANT: Please record product information on page 2. This information is required when calling the factory for service.



Owner's Manual

For
2W40 Series
Worm Gear Hand Winches

Two-Year Limited Warranty

Please record the following:

Date Purchased: _____

Model No.: _____

Code No.: _____

This information is required when calling the factory for service.

Thern, Inc. warrants its products against defects in material or workmanship for two years from the date of purchase by the original using buyer, or if this date cannot be established, the date the product was sold by Thern, Inc. to the dealer. To make a claim under this warranty, contact the factory for an RGA number. The product must be returned, prepaid, directly to Thern, Inc., 5712 Industrial Park Road, Winona, Minnesota 55987. The following information must accompany the product: the RGA number, the date of purchase, the description of the claimed defect, and a complete explanation of the circumstances involved. If the product is found to be defective, it will be repaired or replaced free of charge, and Thern, Inc. will reimburse the shipping cost within the contiguous USA.

This warranty does not cover any damage due to accident, misuse, abuse, or negligence. Any alteration, repair or modification of the product outside the Thern, Inc. factory shall void this warranty. This warranty does not cover any costs for removal of our product, downtime, or any other incidental or consequential costs or damages resulting from the claimed defects. This warranty does not cover brake discs, as these are wear components and their life is subject to use conditions which vary between applications.

FACTORY AUTHORIZED REPAIR OR REPLACEMENT AS PROVIDED UNDER THIS WARRANTY IS THE EXCLUSIVE REMEDY TO THE CONSUMER. THERN, INC. SHALL NOT BE LIABLE FOR ANY INCIDENTAL OR CONSEQUENTIAL DAMAGES FOR BREACH OF ANY EXPRESS OR IMPLIED WARRANTY ON THIS PRODUCT. EXCEPT TO THE EXTENT PROHIBITED BY APPLICABLE LAW, ANY IMPLIED WARRANTY OF MERCHANTABILITY OR FITNESS FOR A PARTICULAR PURPOSE ON THIS PRODUCT IS LIMITED IN DURATION TO THE DURATION OF THIS WARRANTY.

Some states do not allow the exclusion or limitation of incidental or consequential damages, or allow limitations on how long an implied warranty lasts, so the above limitation or exclusion may not apply to you. This warranty gives you specific legal rights, and you may also have other rights which vary from state to state.

Note: Thern, Inc. reserves the right to change the design or discontinue the production of any product without prior notice.

About This Manual

The Occupational Safety and Health Act of 1970 states that it is the employer's responsibility to provide a workplace free of hazard. To this end, all equipment should be installed, operated, and maintained in compliance with applicable trade, industrial, federal, state, and local regulations. It is the equipment owner's responsibility to obtain copies of these regulations and to determine the suitability of the equipment to its intended use.

This Owner's Manual, and warning labels attached to the equipment, are to serve as guidelines for hazard-free installation, operation, and maintenance. They should not be understood to prepare you for every possible situation.

The information contained in this manual is applicable only to the Thern 2W40 Series Worm Gear Hand Winches. Do not use this manual as a source of information for any other equipment.

The following symbols are used for emphasis throughout this manual:

⚠WARNING

Failure to follow 'WARNING!' instructions may result in equipment damage, property damage, and/or serious personal injury.

⚠CAUTION

Failure to follow 'CAUTION!' instructions may result in equipment damage, property damage, and/or minor personal injury.

Important!

Failure to follow 'important!' instructions may result in poor performance of the equipment.

Suggestions for Safe Operation



⚠WARNING

DO the following:

Read and comply with the guidelines set forth in this Owner's Manual. Keep this manual, and all labels attached to the winch, readable and with the equipment at all times. Contact Thern, Inc. for replacements.

Check lubrication before use.

Install the wire rope securely to the winch drum.

Keep at least 4 wraps of wire rope wound on the drum at all times, to serve as anchor wraps. With less than 4 wraps on the drum the wire rope could come loose, causing the load to escape.

Keep hands away from the drum, wire rope, and other moving parts of the equipment.

Keep all unnecessary personnel away from winch while in operation. Keep out of the path of the load and out of the path of a broken wire rope that might snap back and cause injury.

DO NOT do the following:

Do not lift people, or things over people. Do not walk or work under a load or in the line of force of any load.

Do not exceed the load rating of the winch or any other component in the system. To do so could result in failure of the equipment.

Do not use more than one winch to move a load unless each winch was designed for use in a multiple winch system.

Do not use damaged or malfunctioning equipment. To do so could result in failure of the equipment.

Do not modify the equipment in any way. To do so could cause equipment failure.

Do not wrap the wire rope around the load. This damages the wire rope and could cause the load to escape. Use approved rigging connectors to secure the wire rope to the load.

Do not lift loads or pull loads on an incline unless the winch is equipped with a load brake.

Do not divert your attention from the operation. Stay alert to the possibility of accidents, and try to prevent them from happening.

Do not jerk or swing the load. Avoid shock loads by starting and stopping the load smoothly. Shock loads overload the equipment and may cause damage.

Do not leave a suspended load unattended unless specific precautions have been taken to secure the load and keep people away from the winch and out from under the load.

Do not adjust the brake with the load suspended if winch is equipped with a load brake.

Do not exceed the duty cycle rating of the winch when operating with a drill-motor, and do not operate the winch with a drill-motor that exceeds 400 rpm or an impact wrench. To do so could result in equipment damage or failure. See Table 1.

Table 1 – Duty Rating

Drill Drive With Mechanical Brake	15 minutes
Drill Drive Without Mechanical Brake	60 minutes
Manual Input With or Without Mechanical Brake	60 minutes

Do not continue to operate winch if gearbox or brake show signs of overheating.

Allow winch to cool to ambient temperature before continuing operation.

NOTE - 2W40-L Series not intended for drill-motor operation.

1.1 Installing the Winch

Important!

- Inspect the winch immediately following installation according to the Instructions for Periodic Inspection. This will give you a record of the condition of the winch with which to compare future inspections.
- A qualified professional should inspect or design the foundation to insure that it will provide adequate support.
- Locate the winch so it will be visible during the entire operation.
- Do not weld the winch frame to the foundation or support structure. Welding the frame may void warranty, contact Thern, Inc. Use fasteners as instructed.

▲WARNING

Do not install the winch in an area defined as hazardous by the National Electric Code, unless installation in such an area has been thoroughly approved.

Do not install the winch near corrosive chemicals, flammable materials, explosives, or other elements that may damage the winch or injure the operator. Adequately protect the winch and the operator from such elements.

Position the winch so the operator can stand clear of the load, and out of the path of a broken wire rope that could snap back and cause injury.

Attach the winch to a rigid and level foundation that will support the winch and its load under all load conditions, including shock loading.

- 1.1.1 CONSULT APPLICABLE CODES AND REGULATIONS for specific rules on installing the equipment.
- 1.1.2 LOCATE THE WINCH in an area clear of traffic and obstacles. Make sure the winch is accessible for maintenance and operation.
- 1.1.3 LOCATE THE WINCH in an area with adequate temperatures. The winch is rated for operation in ambient temperatures ranging from 0° to 100° F.
- 1.1.4 MAINTAIN A FLEET ANGLE between 1/2 and 1-1/2 degrees. The proper fleet angle minimizes wire rope damage by helping the wire rope wind uniformly onto the drum. See Figure 1.
- 1.1.5 POSITION THE WINCH to allow access for proper lubrication.
- 1.1.6 FASTEN THE WINCH securely to the foundation.
 - a FOR STANDARD PRODUCTS referred to in this manual, use 1/2 - inch coarse thread fasteners, grade 5 or better, torque dry to 75 ft lb without lubrication. Make sure the winch is secured to a solid foundation able to support the winch and the load under all conditions with design factors based on accepted engineering practices.
 - b NON-STANDARD PRODUCTS that vary from the original design may have different fastening requirements. Contact a structural engineer or Thern, Inc. for this information.

TO COMPLY WITH LOCAL CODES, CONTACT A QUALIFIED PROFESSIONAL TO OBTAIN PROPER STRUCTURE OR FOUNDATION SPECIFICATIONS FOR THE MOUNTING OF THERN PRODUCTS.

Important!

- Use a sheave or roller guide to direct the wire rope to the drum whenever possible.
- Install sheaves, tracks and other equipment so they will remain fixed under all load conditions. Follow the recommendations of the equipment manufacturer.
- Use sheaves of proper diameter to minimize wear on the wire rope. Follow the recommendations of the sheave manufacturer.

Figure 1 – Maintaining the Fleet Angle

When wire rope travels over a sheave or through a roller guide – maintain fleet angle by locating the sheave or guide an appropriate distance from the drum, shown as distance “A”.

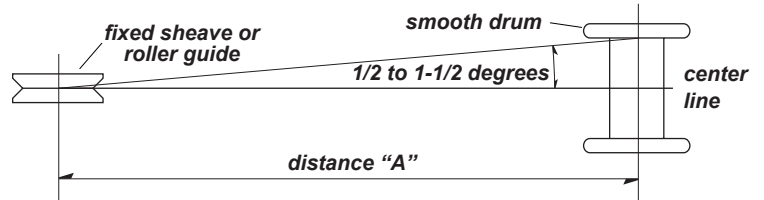

When wire rope travels directly to the load – maintain fleet angle by controlling side-to-side movement of the load with tracks or guide rails. Allowing the load to move too far to one side causes stress on the drum flange which may cause damage.

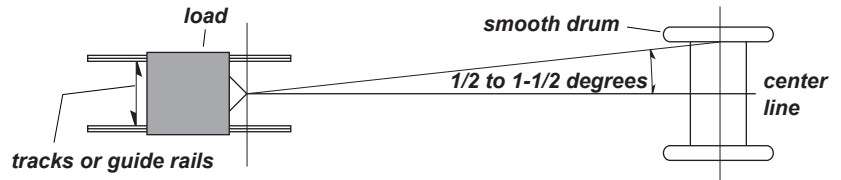

1.2 Installing the Breather Plug

Important!

- Save the extra oil plug for use when the winch is removed for storage, service or transport.

⚠ CAUTION

Install the breather plug to vent heat and pressure from the gearbox and/or brake. Failure to do so could result in pressure buildup which can cause the gearbox or brake to leak or damage the equipment.

For shipment, the gearbox and brake are sealed with oil plugs, and the breather plug is attached to the gearbox or shipped in a separate envelope.

- 1.2.1 REMOVE THE OIL PLUG and install the breather plug in the proper location. Make sure the breather plug is above the oil level. See Figures 2a and 2b.
- 1.2.2 CHECK THE OIL LEVEL in the gearbox and brake to make sure no oil was lost during shipment. See section 3.3 Lubricating the Winch.

Figure 2a – Breather Plug Installation

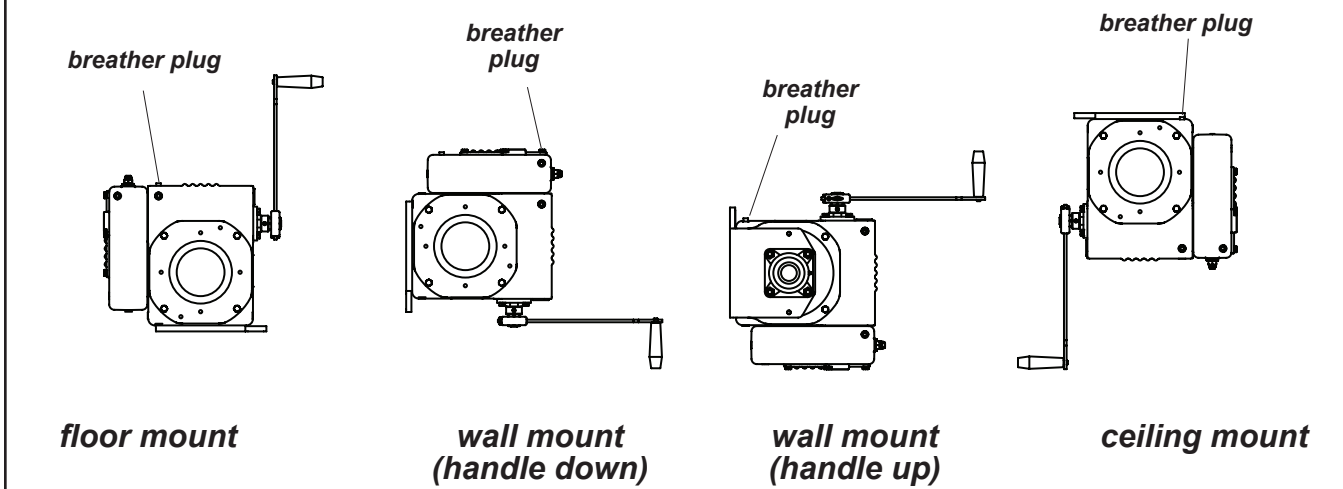
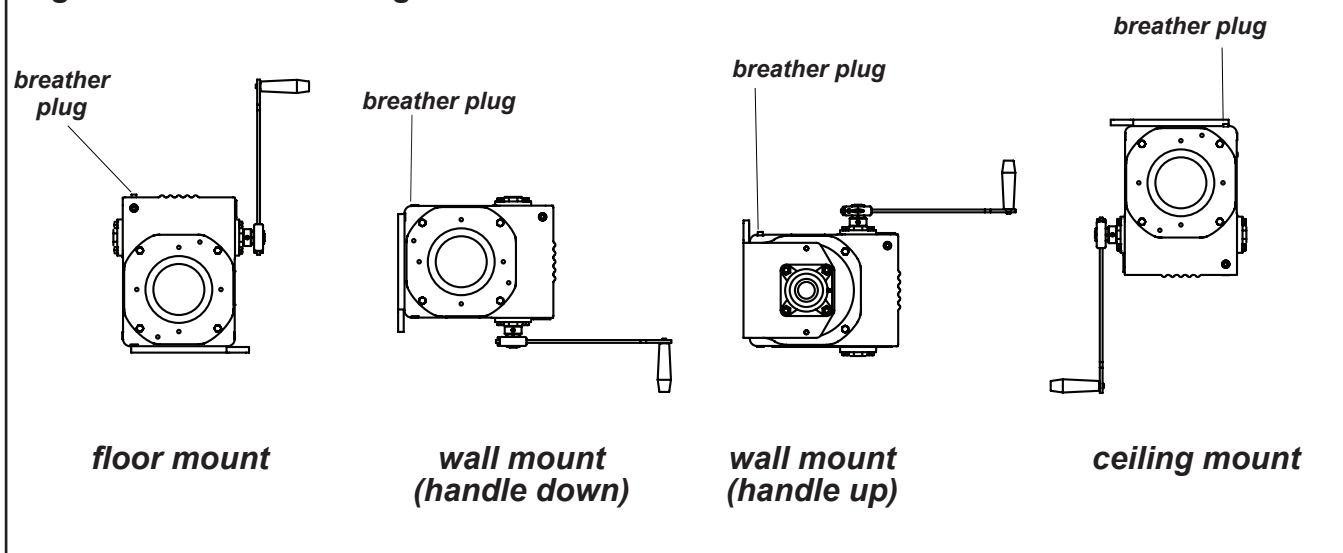

Figure 2b – Breather Plug Installation - Non-Brake Units



1.3 Installing the Handle

CAUTION

When operating winch with handle not at full extension use caution. The end of the handle may hit operator while rotating.

The 2W40-M series includes a 1-1/8 inch hex drive input. You can attach the handle to this input, or you can use a 1-1/8 inch hex socket to power drive the winch with a maximum 400 rpm drill-motor. **Remove the handle before power driving the winch with a drill-motor.**

The 2W40-L series does not include a hex drive input and **is not intended for operation with a drill-motor.**

Figure 3 – Installing the Handle (2W40-M Series)

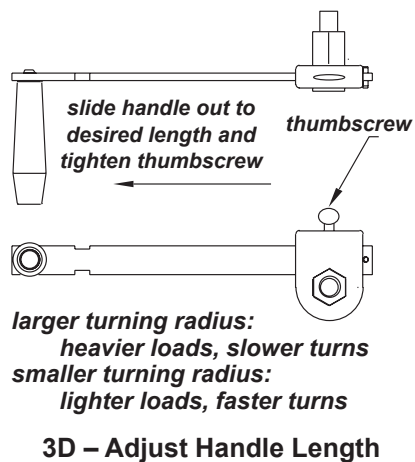
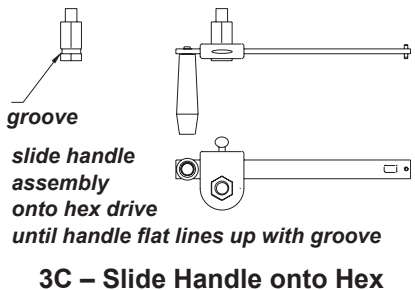
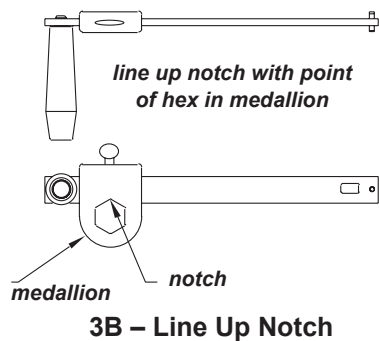
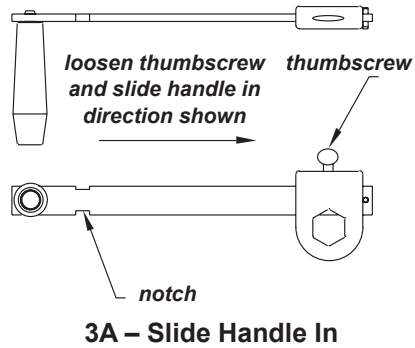

- 1.3.1 LOOSEN THE THUMBSCREW and slide the handle toward the medallion as shown. See 3A.
- 1.3.2 LINE UP THE NOTCH in the handle with the point of the hex in the medallion. See 3B.
- 1.3.3 SLIDE THE HANDLE AND MEDALLION ASSEMBLY onto the hex drive until the flat of the handle lines up with the groove in the hex drive. See 3C.
- 1.3.4 SLIDE THE HANDLE outward away from the medallion to the desired length and tighten the thumbscrew. See 3D.
- 1.3.5 FOR 2W40-L SERIES MODELS, install the handle as follows. See Figure 4.
 - a INSERT THE HANDLE in the handle socket, adjust handle length to suit the operation, and tighten the set screw to hold it in place.
 - b INSERT THE COTTER PIN in the end of the handle and bend the arms back to secure in place.

Figure 4 – Installing the Handle (2W40-L Series)

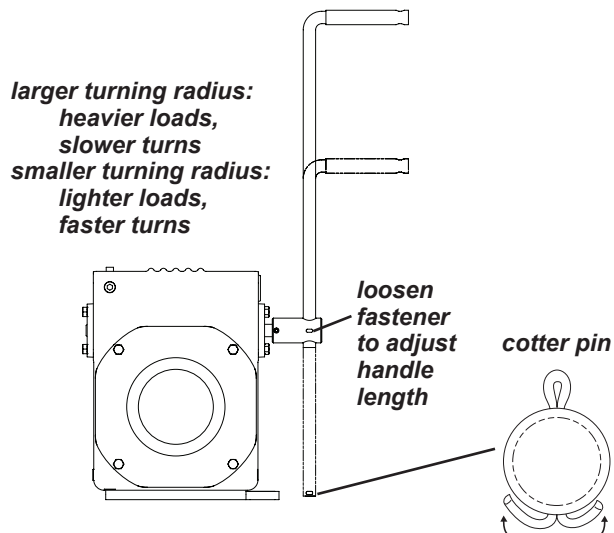

Adjust Handle Length (2W40-L Series)

1.4 Installing the Wire Rope

Important!

- Use wire rope and other rigging equipment rated for the size of the largest load you will be moving.
- Do not drag the wire rope through dirt or debris that could cause damage, or poor operation.
- Always wear protective clothing when handling wire rope.

⚠WARNING

Install the wire rope securely to the winch drum. A poorly secured wire rope could come loose from its anchor and allow the load to escape.

Install the wire rope so it is wound correctly as shown or the winch and brake will not work properly, and could allow the load to escape. See Figure 5.

Install plug to prevent wire rope wrapping in keyhole slot. Wire rope wrapping in slot could damage the wire rope and allow the load to escape. See Figure 5.

Install wire rope anchor fitting to hold the largest load on the winch. Under-sized or improperly installed anchor fitting could come loose from the wire rope or keyhole slot and allow the load to escape. See Figure 5.

Figure 5 – Installing the Wire Rope

install the wire rope so it is underwound on the drum as shown

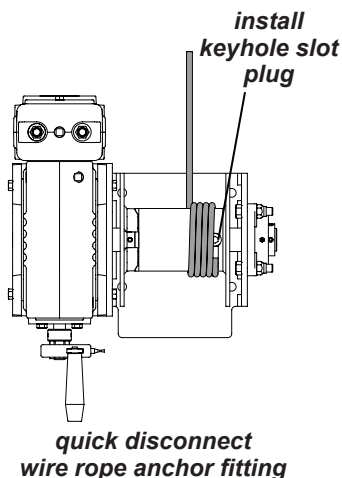
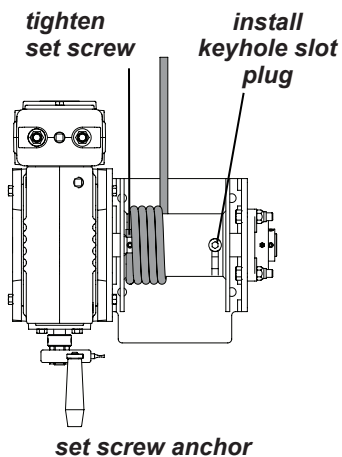

Wire rope assemblies with anchor fittings can be purchased from Thern, Inc.

1.4.1 PURCHASE THE PROPER WIRE ROPE for your application. Contact a reputable wire rope supplier for help.

- BREAKING STRENGTH of new wire rope should be at least 3 times greater than the largest load placed on the winch. If loads are lifted or pulled on an incline, the breaking strength must be at least 5 times greater than the largest load. These are minimum values and will vary with the type of load and how you are moving it.
- WIRE ROPE LAY must agree with the winding direction of the drum to help insure proper winding.
- WE RECOMMEND 7 x 19 galvanized aircraft cable for diameters up to 5/16 inch, and 6 x 37 IWRC improved plow steel for 3/8 inch and up.

1.4.2 ANCHOR THE WIRE ROPE to the drum using either the set screw or quick disconnect anchor.

- SET SCREW ANCHOR. See Figure 5.
 - PASS THE WIRE ROPE under the drum from the front and position it in the recessed anchor hole in the drum. Make sure at least 1/2 inch of wire rope extends past the set screw, and the end of the wire rope does not protrude out where it will interfere with wire rope winding onto the drum.
 - TIGHTEN THE SET SCREW until it flattens the wire rope against the anchor hole. Use enough force to drive the point of the set screw securely into the wire rope.
- QUICK DISCONNECT ANCHOR. See Figure 5.
 - REMOVE PLUG from quick disconnect anchor.
 - PASS THE WIRE ROPE under the drum from the front and position the anchor fitting in the keyhole slot in the drum.
 - RE-INSTALL PLUG and tighten until plug is flush with the drum spool surface and will not come loose during operation.
 - PULL THE WIRE ROPE firmly to anchor the fitting in the keyhole slot. **The anchor fitting needs to be larger than the keyhole slot and be able to hold the load.**

1.4.3 WIND FOUR FULL WRAPS of wire rope onto the drum by operating the winch while holding the wire rope taut. **These wraps serve as anchor wraps and must remain on the drum at all times.** See Figure 5.

2.1 General Theory of Operation

Important!

- Limit nonuniform winding by keeping tension on the wire rope and by maintaining the proper fleet angle.
- It is your responsibility to detect and account for different factors affecting the condition and performance of the equipment.

Table 1 – Duty Rating

Drill Drive With Mechanical Brake	15 minutes
Drill Drive Without Mechanical Brake	60 minutes
Manual Input With or Without Mechanical Brake	60 minutes

Do not continue to operate winch if gearbox or brake show signs of overheating.

Allow winch to cool to ambient temperature before continuing operation.

NOTE - 2W40-L Series not intended for drill-motor operation.

- 2.1.1 THE PULL REQUIRED to move the load must not exceed the load rating of the winch. Consider the total force required to move the load, not the weight of the load.
- 2.1.2 THE AMOUNT OF TIME required to move the load must not exceed the duty cycle rating of the winch. To do so could result in equipment damage or failure. See Table 1.
- 2.1.3 THIS EQUIPMENT CAN develop forces that will exceed the load rating. It is the responsibility of the equipment user to limit the size of the load. Inspect the equipment regularly for damage according to the instructions contained in this manual and in component manufacturer's information.
- 2.1.4 USE A LOAD BRAKE on all winches used to lift loads or pull loads on an incline. Although a new winch may appear to hold the load in place, this characteristic will diminish with use. **Do not depend on gearing to hold the load in place.**
- 2.1.5 PERFORMANCE RATINGS of the equipment are affected by the amount of wire rope wound on the drum, the way in which it is wound, and the way the winch is used.
- a DRUM CAPACITY depends on how tightly and evenly the wire rope is wound on the drum. Actual drum capacities are usually 25-30% less than values shown in performance tables, due to loose winding and over lapping.
 - b FORCE REQUIRED TO LIFT the load increases with each additional layer of wire rope wound onto the drum. The value shown in performance tables is based on an empty drum, and maximum handle length.
 - c LOAD RATING represents the maximum pull that can be placed on new equipment. Load ratings are assigned values for specific amounts of load travel or wire rope accumulation. The load rating decreases as layers of wire rope accumulate on the drum.
- 2.1.6 DUTY RATINGS refer to the type of use the equipment is subject to. For duty ratings, see Table 1. Consider the following when determining duty rating.
- a ENVIRONMENT: harsh environments include hot, cold, dirty, wet, corrosive, or explosive surroundings. **Protect the equipment from harsh environments when possible.**
 - b MAINTENANCE: poor maintenance, meaning poor cleaning, lubrication, or inspection, leads to poor operation and possible damage of the equipment. **Minimize poor maintenance by carefully following the instructions contained in this manual.**
 - c LOADING: severe loading includes shock loading and moving loads that exceed the load rating of the equipment. **Avoid shock loads, and do not exceed the load rating of the equipment.**
 - d FREQUENCY OF OPERATION: frequent or lengthy operations increase wear and shorten the life span of gears, bearings, and other components. **Increase maintenance of the equipment if used in frequent operations. Length of operation should not exceed the duty cycle rating of the winch. To do so could result in equipment damage or failure. See Table 1.**

CONTACT THE FACTORY FOR MORE INFORMATION.

2.2 Breaking-In the Winch

- 2.2.1 BREAK-IN OCCURS during the first few hours of normal operation. During break-in, mating surfaces become polished, and clearances increase. This is desired for efficient operation of bearings and gears.
- 2.2.2 INSPECT THE WINCH following break-in according to the Instructions for Periodic Inspection. See section 3.4 Inspecting the Equipment.

2.3 Preparing for Operation

Important!

- When determining whether the load will exceed the load rating, consider the total force required to move the load.

- 2.3.1 CONSIDER THE OPERATION. Do not begin until you are sure you can perform the entire operation without hazard.
- 2.3.2 INSPECT ALL COMPONENTS of the system.
- a INSPECT THE WINCH and other equipment according to the Instructions for Frequent Inspection.
 - b OPERATORS must be in good health, alert, thoroughly trained in operating the equipment, and properly clothed (hard hat, safety shoes and safety glasses, no loose clothing).
 - c THE LOAD must be clear of other objects and free to move. Make sure the load will not tip, spin, roll away, or in any way move uncontrollably.
- 2.3.3 KNOW YOUR LOAD and make sure you do not exceed the load rating of the winch or any other equipment in the system.

2.4 Attaching the Load

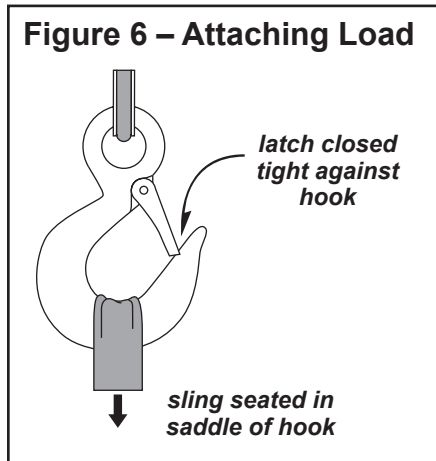

⚠ WARNING

Do not wrap the wire rope around the load. This damages the wire rope and could cause the load to escape. Use a sling or other approved rigging device.

- 2.4.1 CLEAR OBJECTS from the path of the load so you can move it freely and observe it at all times during the operation.
- 2.4.2 ATTACH THE LOAD using a nylon sling, or other approved rigging device. Follow the recommendations of the sling manufacturer.
 - a SEAT THE SLING in the saddle of the hook with the hook latch completely closed. See Figure 6.
 - b CENTER THE LOAD on the hook so it will remain balanced and not tip or rotate to one side.

2.5 Moving the Load

Important!

- Obey a stop signal from anyone.
- Maintain tension on the wire rope to keep it tightly and evenly wound on the drum.
- If the winch and load are not visible during the entire operation, get help from another person.
- Appoint a supervisor if more than one person is involved in the operation. This will reduce confusion and increase safety.
- When lifting a load, use a tag line to keep the load from swinging or twisting, while keeping yourself away from the load.
- Remove the winch handle when the winch is not in use, to help avoid unauthorized use.

- 2.5.1 MOVE THE LOAD slowly and smoothly, only a small distance at first. Make sure the load is balanced and securely attached before continuing.
- 2.5.2 TURN THE HANDLE COUNTER-CLOCKWISE to wind wire rope onto the drum. If wire rope unwinds from the drum when the handle is rotated counter-clockwise, the wire rope is installed incorrectly. **Install the wire rope correctly before continuing. See Figure 5.**
- 2.5.3 DO NOT EXCEED DUTY CYCLE RATING of the winch. See Table 1.
- 2.5.4 OBSERVE THE WIRE ROPE as it winds onto the drum. If it becomes loose, uneven, or overlapped, stop the operation and rewind the wire rope before continuing. **Continued operation with overlapped or uneven wire rope can damage the wire rope and shorten its life.**
- 2.5.5 ALLOW THE WINCH TO COOL DOWN to ambient temperature in rest periods between operations.
- 2.5.6 OBSERVE THE GEARBOX AND BRAKE during operation for signs of overheating. **Frequent overheating may be a sign of damage, or may indicate the need for a larger winch.**
 - a WATCH FOR SMOKE, the smell of burnt oil, and other signs of overheating. Use a thermocouple or other device to monitor gearbox temperature. The temperature of the oil should not exceed 180° F.
 - b STOP THE OPERATION if the gearbox or brake overheats, and allow the winch to cool until it reaches ambient temperature. **Continued operation may cause damage.**

3.1 Cleaning the Winch

Clean the winch to remove dirt and help prevent rust and corrosion.

- 3.1.1 CLEAN THE WINCH every 6 months or whenever it is dirty.
 - a WIPE ALL EQUIPMENT to remove dirt and grease.
 - b LEAVE A LIGHT FILM of oil on all surfaces to protect them against rust and corrosion.
 - c WIPE OFF excessive amounts of oil to avoid the accumulation of dirt.
- 3.1.2 REMOVE ALL UNNECESSARY OBJECTS from the area surrounding the winch.

Important!

Increase the frequency of maintenance procedures if the winch is:

- Operated for long periods.
- Used to pull heavy loads.
- Operated in wet, dirty, hot, or cold surroundings.

3.2 Adjusting the Brake

(for models equipped with this feature)

⚠WARNING

Do not adjust the brake with the load suspended. Accidental release of the brake could allow the load to escape.

The torque can be measured by using a dial type torque wrench or equal to measure the handle effort (torque) required to turn the input shaft.

- 3.2.1 ADJUST THE BRAKE whenever it appears to need adjustment, or at least every 3 months.
- 3.2.2 CHECK THE BRAKE by operating the winch with a load equal to the winch load rating.
 - a RAISE THE LOAD, then lower it and stop it about one foot off the ground.
 - b OBSERVE THE LOAD when stopped. If it continues to coast or creep, follow the instruction below:
 - **FOR 2W40-B SERIES** use a torque wrench with 1 1/8 socket installed on the input shaft hex. Rotate the torque wrench one complete clockwise revolution of the input shaft. Adjust the brake nuts based on the torque reading and the torque setting specified for the winch. See Table 2. **Do not adjust the brake with the load suspended.**
 - **TIGHTEN THE BRAKE** by turning the adjusting nuts clockwise about 1/4 turn. Continue to test and tighten the brake by alternate tightening of each brake nut until brake stops and holds the load securely. See Figure 7.

Figure 7 – Adjusting the Brake

2W40-B Series

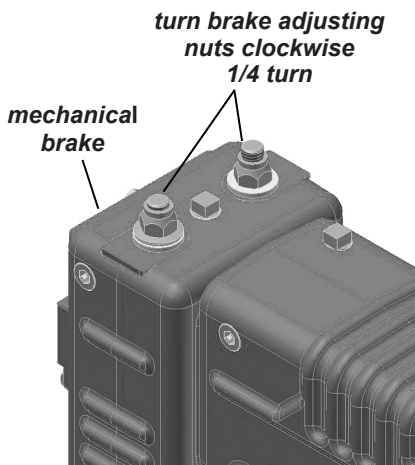

Table 2 - Torque Adjustment¹

Condition	Torque Setting (ft-lbs)	Direction ²
Under No Load	10 - 40	Clockwise
Under Load	4 (minimum) ³	Clockwise

¹ Do not adjust brake with load suspended.

² Complete 1 full rotation.

³ Tighten brake until the minimum value is obtained.

3.3 Lubricating the Winch

Important!

- Do not leave plug holes in the reducer open. Open plug holes will allow dirt and moisture to contaminate the lubrication.
- Make sure lubricant has a temperature rating appropriate for the ambient temperatures of the operation.

Figure 8 – Lubricating the Flange Bearing

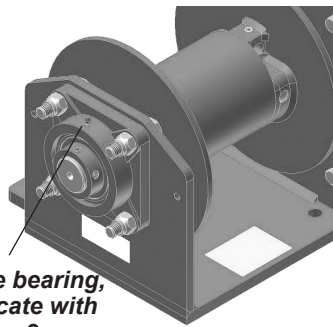

*flange bearing,
lubricate with
NLGI no. 2 grease*

Important!

- For wall mounts with mechanical brake and handle down, remove from wall to allow oil to properly drain from the brake and gearbox.

⚠ CAUTION

Install the breather plug to vent heat and pressure from the gearbox or brake. Failure to do so could result in pressure buildup which can cause the gearbox or brake to leak or damage the equipment.

The breather plug must be located above the oil level otherwise oil will leak through the plug. See Figures 9a and 9b.

Check the gearbox and mechanical brake for proper level before operating. Too much or too little oil will cause overheating and result in equipment damage.

Lubricate the winch properly to help protect it from wear and rust. Apply thread sealant to pipe plugs when re-installing to prevent oil leaks. Read the following instructions carefully.

- 3.3.1 THE WINCH is shipped from the factory with the proper amount of Mobilgear 600XP220 lubricant in the gearbox and brake. Lubricate the winch as follows. See Figures 9a and 9b.
- 3.3.2 CHANGE GEARBOX AND BRAKE OIL after the first 40 hours of operation.
- 3.3.3 CHECK OIL LEVEL before every operation and every 10 hours during operation. Remove the level check plug and make sure oil is even with the plug hole. Add oil to the gearbox and brake if necessary. **Do not use synthetic lubricants and do not mix different lubricants.**
- 3.3.4 CHANGE GEARBOX AND MECHANICAL BRAKE OIL at least every 6 months, or whenever it is dirty or contaminated. Remove the drain plug to drain oil from the gearbox and brake. See Figures 9a and 9b.
 - a For wall mount installations with a mechanical brake fill the bottom compartment (brake or gearbox), then top compartment. Allow time for oil to settle and check oil level at level check plug. Apply thread sealant to pipe plug threads upon re-installation.
 - b For ceiling mount installation fill the gearbox first, then brake if equipped. Allow time for oil to settle and check gearbox oil level at level check plug. Apply thread sealant to pipe plug threads upon re-installation.
- 3.3.5 LUBRICATE THE FLANGE BEARING at least once every month or more, depending on usage. Use a grease gun to insert NLGI no. 2 grease until clean grease appears at the seals. The bearing will squeak if it is dry. See Figure 8.
- 3.3.6 LUBRICATE THE WIRE ROPE and other equipment by following the manufacturers recommendations.

Figure 9a – Lubricating the Winch - Brake Units

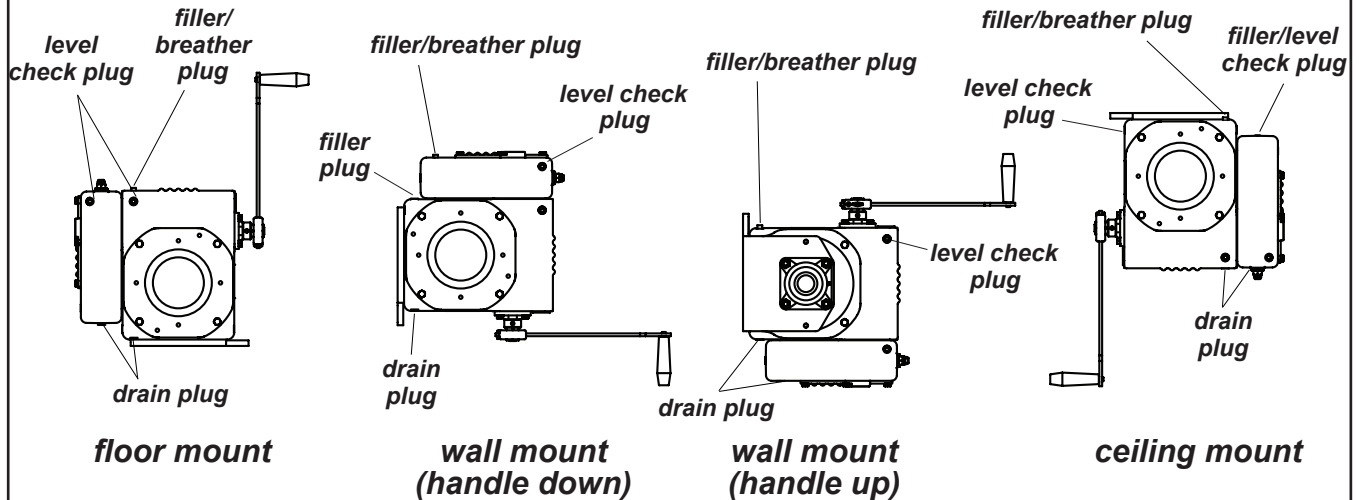

Note: Drain plugs are hexagon socket pipe plugs. Do not remove bolts or nuts to drain oil.

Figure 9b – Lubricating the Winch - Non-Brake Units

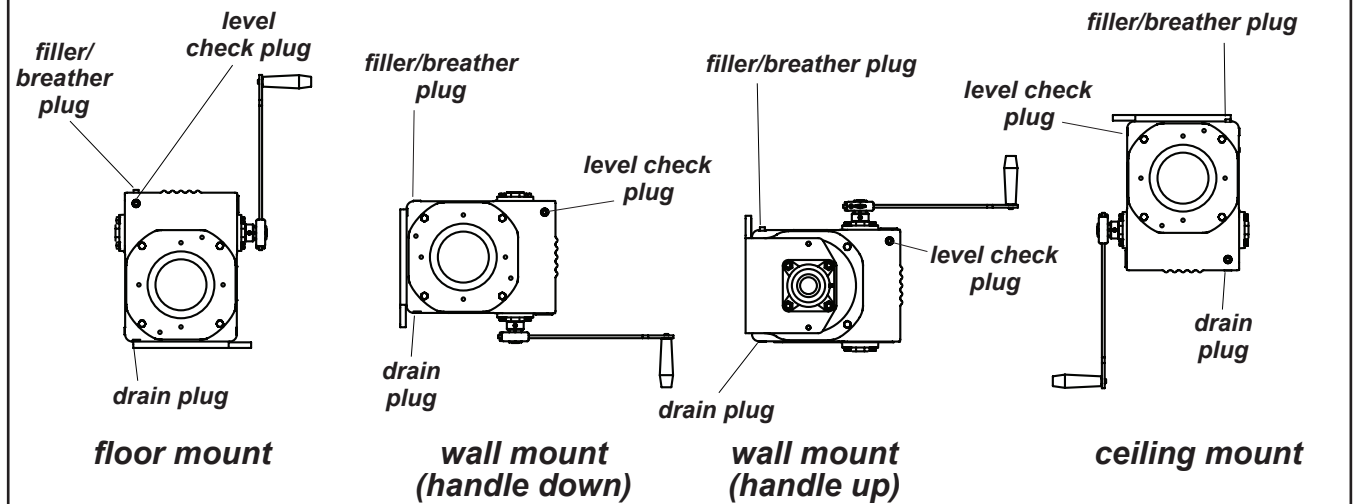

Note: Drain plugs are hexagon socket pipe plugs. Do not remove bolts or nuts to drain oil.

3.4 Inspecting the Equipment

Important!

- Start an inspection program as soon as you put the winch into use.
- Appoint a qualified person to be responsible for regularly inspecting the equipment.
- Keep written records of inspection. This allows comparison with comments from previous inspections so you can see changes in condition or performance.

Perform frequent inspections:

- Before each operation.
- Every 3 hours during operation.
- Whenever you notice signs of damage or poor operation.

⚠WARNING

Do not use damaged or malfunctioning equipment. Place an “OUT OF ORDER” sign on the winch. Do not use the winch until the sign is removed by a qualified maintenance person who has completely corrected the problem.

Inspect the winch to detect signs of damage or poor operation before they become hazardous.

3.4.1 CONSULT APPLICABLE CODES AND REGULATIONS for specific rules on inspecting the winch and other equipment.

3.4.2 CONSULT MANUFACTURER'S RECOMMENDATIONS for information on inspecting the wire rope and other equipment.

3.4.3 Instructions for Frequent Inspection

- a VISUALLY INSPECT the entire winch and all other equipment involved in the operation.
 - Check all equipment for cracks, dents, bending, rust, wear, corrosion and other damage.
 - Make sure the wire rope is installed correctly and anchored securely to the drum.
 - Make sure the winch is properly lubricated.
 - Make sure the thumbscrew holding the handle in place is tight.
 - Check the gearbox and mechanical brake for signs of leakage, and make sure it is filled with the proper lubricant. Contact the factory if there are any signs of lubricant leaking from the gearbox or brake.
 - Make sure the breather plug is clean, open, and installed correctly.
 - Make sure mounting fasteners are tightened securely.
 - Make sure the foundation is in good condition, and capable of supporting the winch and its load under all load conditions.
- b TEST WINCH PERFORMANCE by moving a test load not exceeding the load rating.
 - Listen for unusual noises, and look for signs of damage as you operate the winch.
 - Make sure the wire rope winds evenly and tightly onto the drum. If it is loose or uneven, rewind it before continuing.
 - Make sure the load moves smoothly, without hesitation or strain.
 - Make sure the handle rotates freely in both directions.
 - On models equipped with a brake, check the brake. Raise the load, then lower it and stop it a few feet off the ground. If the load continues to coast or creep, the brake needs adjustment. See Section 3.2 Adjusting the Brake.

Completely correct all problems before continuing. Use the Troubleshooting Chart to help determine the cause of certain problems. See Table 4.

Perform periodic inspection:

- Every 6 months.
- Whenever you return the winch to service from storage.
- Whenever you notice damage or poor operation in a frequent inspection.
- Whenever you have, or think you have, overloaded or shock loaded the winch.

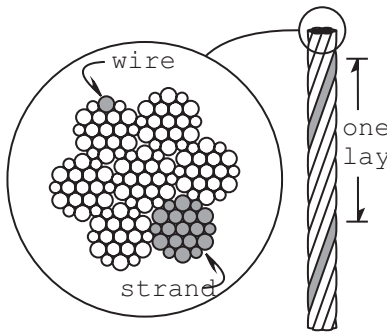
Figure 10 – Broken Wires

Wire rope assembly must be replaced if more than 6 wires are broken in one lay, or if more than 3 wires are broken in one strand in one lay.

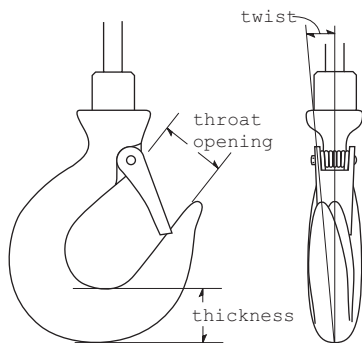
Figure 11 – Load Hook Inspection

The wire rope assembly must be replaced if the throat opening is 15% wider than nominal, if the thickness is 10% less than nominal, or if the hook is twisted 10° or more.

3.4.4 Instructions for Periodic Inspection, see Table 3.

- a VISUALLY INSPECT the winch and all other equipment.
 - Disassembly may be required in order to properly inspect individual components. Contact factory for assembly/disassembly instructions. Disassembly of the gearbox before contacting Thern, Inc voids all warranties.
 - Check the finish for wear, flaking, or other damage.
 - Check all equipment for cracks, dents, bending, rust, wear, corrosion and other damage. If the equipment was overloaded, or if you notice cracks and other signs of overloading and damage, promptly remove equipment from use and have it repaired or replaced. **DO NOT CONTINUE TO USE DAMAGED OR OVERLOADED EQUIPMENT OR WIRE ROPE.**
 - Check all fasteners for stripped threads, wear, bending, and other damage.
 - Check the gearbox and mechanical brake for signs of leakage. Contact factory if there are any signs of lubricant leaking from the gearbox or brake.
 - Make sure the breather plug is clean, open and installed correctly.
 - Make sure the winch outboard bearing is properly lubricated.
 - Make sure all labels and plates are readable, firmly attached, free of damage and clean. Replacements are available from the factory.
- b DRAIN A SMALL AMOUNT OF OIL from the gearbox and brake into a clean container.
 - Check the oil for dirt, metal particles, water, and other signs of contamination. Completely drain the gearbox if oil is contaminated.
 - Make sure the gearbox and brake is properly lubricated. See Section 3.3 Lubricating the Winch.

Frequent Wire Rope Inspection:

- Use ASME B30.7 as a guideline for rope inspection, replacement and maintenance.
- Check the wire rope, end connections and end fittings for corrosion, kinking, bending, crushing, birdcaging or other signs of damage.
- Check the number, distribution and type of visible broken wires. See paragraph 3.4.4 c and Figure 10.
- Check the wire rope for reduction of rope diameter from loss of core support, or wear of outside wires. See Figure 12.
- Take extra care when inspecting sections of rapid deterioration such as sections in contact with saddles, sheaves, repetitive pickup

Figure 12 – Rope Diameter

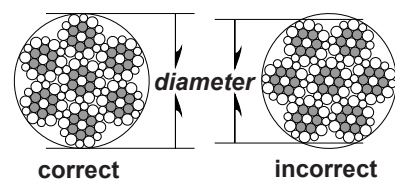

The wire rope assembly must be replaced if the diameter measures less than the minimum diameter at any point.

wire rope diameter	minimum diameter
1/4 in	15/64 in (.2344 in)
5/16 in	19/64 in (.2969 in)
3/8 in	11/32 in (.3438 in)
1/2 in	15/32 in (.4688 in)

- c INSPECT THE WIRE ROPE according to the wire rope manufacture’s recommendations, or follow accepted industry standards for wire rope inspection.
 - Always wear protective clothing when handling wire rope.
 - Check the entire length of wire rope for bent wires, crushed areas, broken or cut wires, corrosion, and other damage. Carefully inspect areas that pass over sheaves or through roller guides.
 - Note the location and concentration of broken wires. Replace wire rope if more than 6 wires are broken in one lay, or more than 3 wires are broken in one strand in one lay. See Figure 10.
 - Make sure hooks and other fittings are securely attached to the wire rope, and the wire rope where they are attached is not frayed, corroded, broken, or otherwise damaged.
 - Measure the throat opening, thickness, and twist of the hook. Replace the hook if it shows signs of damage. See Figure 11.
 - Make sure any hook latches open without binding and close when released.
 - Check the anchor holes in the drum and the surrounding area for signs of wear or distortion.
- d MOVE THE DRUM with your hands. Check for excessive movement indicating worn or loose gears, bearings, or shafts. Slight endplay in the driveshaft is normal. Excessive movement is caused by overloading or overheating, and is a sign that your application may require a larger winch.
- e PLACE enough weight to keep the wire rope straight and tightly drawn.
 - Measure the diameter of the wire rope, especially in areas where wear is noticeable. Replace the wire rope if the diameter measures below the minimum diameter at any point. See Figure 12.
- f INSPECT THE FOUNDATION AND RIGGING.
 - Check mounting fasteners for stripped threads, wear, and other damage.
 - Check the foundation for cracks, corrosion, and other damage.
- g TEST WINCH PERFORMANCE by operating the winch with a test load equal to the load rating.
 - Listen for unusual noises, and look for signs of damage as you operate the winch.
 - Make sure the wire rope winds evenly and tightly onto the drum. If it is loose or uneven, rewind it before continuing.
 - Observe the rotating drum, look for signs of loose or misaligned bearings.
 - Make sure the load moves smoothly, without hesitation or strain.
 - Make sure the handle rotates freely in both directions.
 - On models equipped with a brake, check the brake. Raise the load, then lower it and stop it a few feet off the ground. If the load continues to coast or creep, the brake needs adjustment. See Section 3.2 Adjusting the Brake.

Completely correct all problems before continuing. Use the troubleshooting chart to help determine the cause of certain problems. See Table 4.

3.5 Repairing the Winch

Important!

- It is your responsibility to determine when to replace parts. When considering whether to continue using a part or to replace it, remember that replacing it is the best way to avoid further equipment damage.
- Replace spring pins, retaining rings, and oil seals whenever the winch is disassembled for inspection or repair.
- During reassembly, use loctite 598 Ultra Black to create a seal between gearbox covers, end caps or mechanical brake if equipped. Contact factory for detailed instructions. Disassembly of the gearbox before contacting Thern, Inc. voids all warranties
- Appoint a qualified person to be responsible for all repairs to the equipment.

- 3.5.1 GET FACTORY AUTHORIZATION for all repairs. Unauthorized repairs will void the warranty, and may lead to damage or failure of the winch.
- 3.5.2 REPLACE DAMAGED OR POORLY OPERATING PARTS with Thern repair parts.
- 3.5.3 REFINISH AREAS where the paint is worn or flaking. A good finish helps to protect against corrosion and weather damage.
 - a REMOVE THE FINISH from damaged areas, down to the bare metal.
 - b CLEAN THE AREA thoroughly.
 - c REPAINT with a high quality primer and finishing coat.
- 3.5.4 TO ORDER REPAIR PARTS, contact your local dealer. Include the following information when ordering:
 - model number
 - **serial number** (or code number)
 - part number
 - date purchased, and from whom
 - description of what happened, or what is wrong
 - your name and return address

Table 4 – Troubleshooting Chart

Contact the factory for detailed instructions on re-sealing the gearbox if you are required to disassemble the gearbox for any reason. Disassembly of the gearbox before contacting Thern, Inc. voids all warranties.

problem	cause	correction
handle turns, drum doesn't turn	<ul style="list-style-type: none"> • loose or broken spring pins or shafts • loose, stripped or broken gears or keys 	<ul style="list-style-type: none"> inspect winch and brake, repair as necessary repair as necessary
handle turns hard or not at all	<ul style="list-style-type: none"> • unit overheated..... • load too heavy • gearbox contaminated with dirt or debris • keys or spring pins loose or broken..... • brake band too tight..... • brake broken or locked..... • gears or bearings broken or locked..... 	<ul style="list-style-type: none"> allow to cool lighten load inspect and relubricate as necessary inspect winch and brake, repair as necessary loosen brake and readjust inspect and repair as necessary inspect and replace as necessary
brake does not operate properly	<ul style="list-style-type: none"> • wire rope installed improperly..... • brake adjusted incorrectly • brake worn or damaged • brake components seized up or damaged 	<ul style="list-style-type: none"> reinstall wire rope correctly adjust brake inspect and replace as necessary inspect and repair as necessary
lubricant leakage	<ul style="list-style-type: none"> • worn bearings..... • oil seals leaking or damaged..... • gaskets leaking or damaged • cracked or damaged gearbox..... • gearcase plugs not tightened • breather plug clogged or damaged 	<ul style="list-style-type: none"> inspect and replace as necessary inspect and replace as necessary tighten fasteners or replace gasket inspect and repair as necessary tighten clean or replace vent plug as needed
excessive end play on drive shaft	<ul style="list-style-type: none"> • loose or damaged keys or keyways • thrust washer or bearing worn out..... • excessively worn gears 	<ul style="list-style-type: none"> inspect and replace as necessary inspect and replace as necessary inspect and repair as necessary
excessive worn gears or bearings	<ul style="list-style-type: none"> • load too heavy • poor lubrication of gears or bearings..... 	<ul style="list-style-type: none"> lighten load inspect and lubricate as necessary
overheating	<ul style="list-style-type: none"> • operated too long without rest • load too heavy • poor lubrication • breather plug clogged or damaged • bearing seized up 	<ul style="list-style-type: none"> allow to cool lighten load inspect and lubricate as necessary clean or replace breather plug inspect and replace as necessary
unusual noises		
high pitched squeak	<ul style="list-style-type: none"> • poor lubrication 	inspect and lubricate as necessary
grinding noise	<ul style="list-style-type: none"> • contaminated lubrication • dirt in winch gears • broken gears or bearings 	<ul style="list-style-type: none"> drain, clean and lubricate the winch inspect and clean as necessary inspect and replace as necessary
rattling noise	<ul style="list-style-type: none"> • loose fasteners or set screws..... 	tighten all fasteners and screws
heavy thump during operation	<ul style="list-style-type: none"> • contaminants in lubricant..... • loose set screws or keys in gears or shafts..... • bearings defective 	<ul style="list-style-type: none"> drain, clean and lubricate the winch inspect and repair as necessary inspect and replace as necessary
knocking noise	<ul style="list-style-type: none"> • brake out of adjustment..... 	adjust mechanical brake
	<ul style="list-style-type: none"> • loose or worn parts on input shaft 	contact factory
back drive	<ul style="list-style-type: none"> • brake out of adjustment..... 	adjust brake per manual

4.1 Transporting the Winch

Important!

- Keep a record of what you ship, and when you send it.

- 4.1.1 REMOVE THE BREATHER PLUG and install a sealed oil plug to prevent the loss of lubrication during shipment.
- 4.1.2 PACK THE WINCH in an upright position for transport, using the original packaging materials, if possible.
 - a FASTEN THE WINCH to a wooden base using lag bolts, to keep it from moving during transport.
 - b SEAL THE WINCH in plastic with a desiccant to help protect it from rust, corrosion, and other damage.
 - c CONSTRUCT WOODEN SIDES and top to enclose the winch in a solid protective crate.
 - d PACK LOOSE PARTS in small boxes or ship separately.
- 4.1.3 INSPECT THE WINCH according to the Instructions for Periodic Inspection before installing it in a new location.

4.2 Storing the Winch

- 4.2.1 LUBRICATE THE WINCH as necessary, and make sure the breather plug is clean and properly installed. Add a rust preventative for long term storage.
- 4.2.2 SEAL THE WINCH in plastic with a desiccant to help protect it from rust, corrosion, and other damage.
- 4.2.3 STORE THE WINCH upright, in a cool clean place away from corrosive chemicals and moisture.
- 4.2.4 ROTATE THE DRUM PERIODICALLY to keep bearing and gears surfaces from becoming lacquered.
- 4.2.5 INSPECT THE WINCH according to the Instructions for Periodic Inspection before installing it for operation.
- 4.2.6 LUBRICATE THE WINCH PROPERLY prior to operation. See Section 3.3 Lubricating the Winch.

Series 2W40 Performance Characteristics¹

model number	load rating (lb)			wire rope dia. (in)	drum capacity (ft)			gear ratio	force ² to lift 1000 lb	approx. ship wt. (lb)
	1st layer	mid drum	full drum		1st layer	mid drum	full drum			
2W40-L	4000	2800	2200	.38	14	65	140	26:1	18	111
2W40-BL	4000	2800	2200	.38	14	65	140	26:1	18	107
2W40-M	4600	3300	2500	.38	14	65	140	31:1	11	123
2W40-BM	4600	3300	2500	.38	14	65	140	31:1	11	119

¹ Performance Characteristics are for standard products referred to in this manual. Non-standard products may vary from the original design. Contact Thern, Inc. for this information.

² Approximate handle force required to lift 1,000 lb with an empty drum, and maximum handle length.

Model 2W40-L

item	description	part number	qty.
1	END CAP	B4866	2
2	CAPSCR HEXHD .375-16NC X 1.000 ZNPL GR5	A2922	12
3	INPUT SHAFT	B5094	1
4	SEAL OIL .750ID X 1.375OD X .250	A9518	2
5	BRG RAD BALL .750ID X 1.625OD X .31W STL	A9793	4
6	PLUG BREATHER .375-18NPT X .48 PLN STL	A3408	1
7	BRG BALL THRUST .753ID X 1.685OD X .625	A1498	2
8	WORM SPACER	A10243	2
9	KEY .188 X .188 X 2.000 4140 HT BER	A3255	1
10	WORM 3.250OD X 2.750PD X 2.17RD 1 LEAD	B5392	1
11	GEARCASE MACHINING	D3244	1
12	SHIM .760/.786 X 1.235/1.265 X .018/.024	A4389	2
13	PLUG PIPE HEXSOC .375-18NPT X .425 SAE	A3290	6
14	PIN SLOTTED SPRING .250 X 1.500 STL	A4499	2
15	HANDLE ASSEMBLY	B1015	1
16	HANDLE SOCKET	A10866	1
17	SETSCR SQHD .375-16NC X .500 ZNPL STL	A3725	1
18	PIN COTTER .187 X 1.250 ZNPL STL	A3155	1
19	KEY .500 X .500 X 1.000 4140 HT BES	A10120	2
20	WORM GEAR 8.12OD X 7.750PD X 7.469RD	C4605	1
21	DRUM SHAFT	D3182	1
22	BRG RAD BALL 45MM X 85MM X 19MM	A9968	2
23	FRONT COVER MACHINING	C4378	1
24	SHIM 1.883 X 2.750 X .060 STL	A10124	2
25	SEAL OIL 1.625ID X 2.252 X .313	A9967	1
26	BACK COVER MACHINING	C4377	1
27	CAPSCR HEXHD .375-16NC X 1.500 ZNPL GR5	A3236	4
28	PIN GROOVE TYPE A .500 X 3.750 ALYSTL	A2558	1
29	FRAME WELDMENT	C4379	1
30	BRG FLNG 1.44ID 4 BOLT SETSCR LOCK	A10429	1
31	NUT HEX NYLK .500-13NC ZNPL GR2	A2897	4
32	CAPSCR HEXHD .500-13NC X 2.000 ZNPL GR5	A2894	4
33	PLUG PIPE HEXSOC .500-14NPT X .63 SAE	A3126	1
34	SETSCR SOKHD NYLK .375-16NC X .625	A3128	1
35	DRUM WELDMENT	C4637	1
36	LABEL MODEL/CAPACITY 2W40-L SERIES	A10873	1
37	LABEL WARNING KEEP HANDS AWAY FROM DRUM	A2659	2
38	LABEL NAMEPLATE THERN LOGO	A6889	1
39	LABEL WARNING FOR NON BRAKE WINCHES	A10806	1
40	LABEL DATE OF MANUFACTURE	10477	1

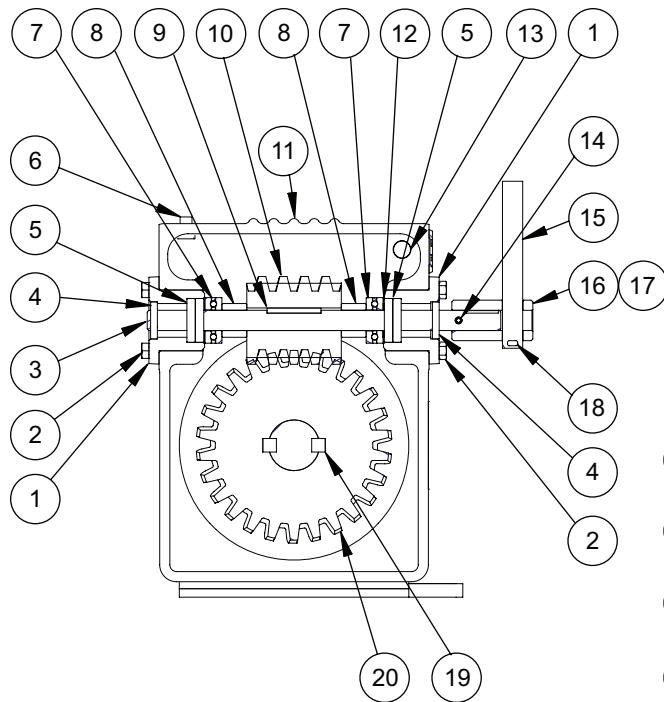

SECTION A-A

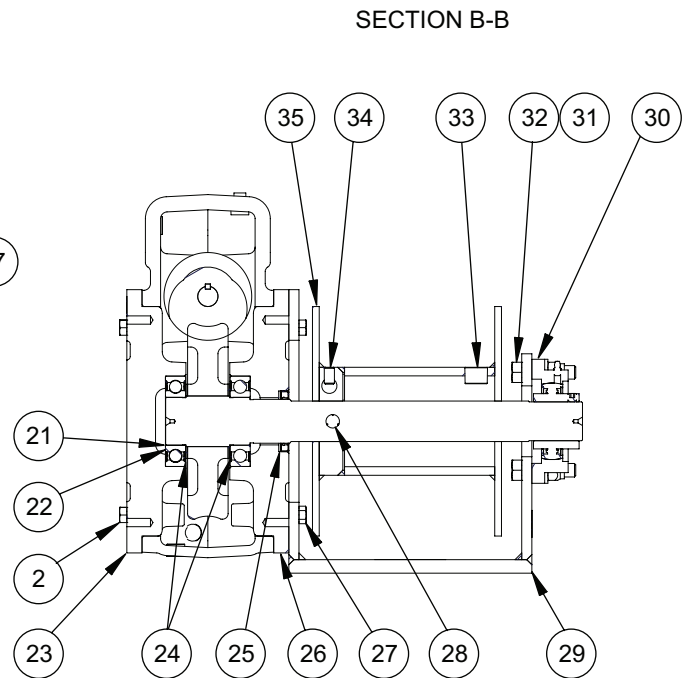

SECTION B-B

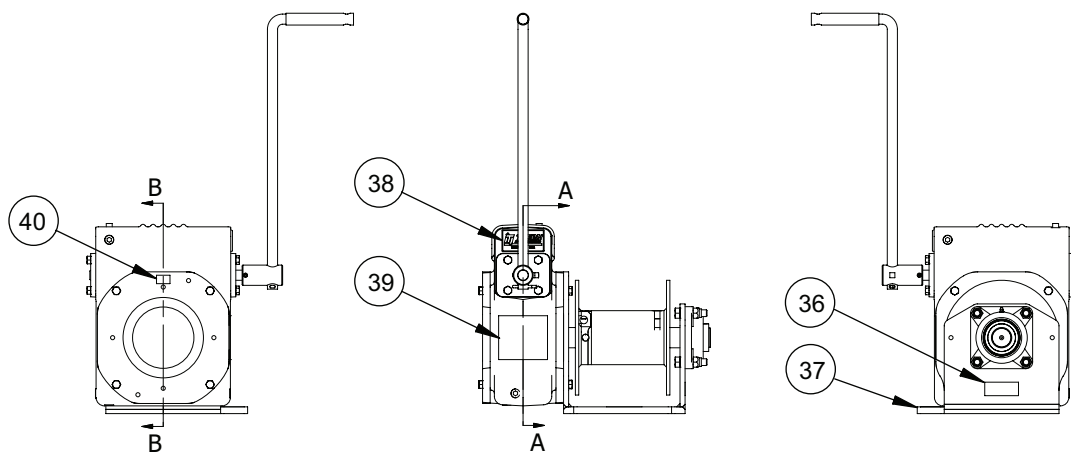

Model 2W40-BL

item	description	part number	qty.
1	PLUG PIPE HEXSOC .375-18NPT X .425 SAE	A3290	12
2	BRAKE HOUSING MACHINING	D3257	1
3	MACHINING COVER BRAKE	C4450	1
4	CAPSCR HEXHD .375-16NC X 1.000 ZNPL GR5	A2922	12
5	BRG RAD BALL .750ID X 1.625OD X .31W STL	A9793	4
6	BRG RAD BALL 1.000 X 2.000 X .375	A2056	1
7	INPUT SHAFT	B4872	1
8	THRUST BEARING	A9804	3
9	BRG CLUTCH 1.000ID X 1.312OD X 1.063 STL	A9844	1
10	BRAKE DRUM	B4995	1
11	CAPSCR HEXHD .312-18NC X .750 ZNPL GR5	A3032	4
12	BRAKE BAND ASSEMBLY	B4991	1
13	PIN DOWEL .250 X 2.000 ALYSTL	A9845	2
14	CONNECTOR BUSHING	A9812	2
15	NUT HEX NYLK .500-13NC ZNPL GR2	A2897	6
16	BRAKE BAND CONNECTOR	A9803	2
17	PLUG BREATHER .375-18NPT X .48 PLN STL	A3408	1
18	BRG BALL THRUST .753ID X 1.685OD X .625	A1498	2
19	WORM SPACER	A10243	2
20	WORM 3.250OD X 2.750PD X 2.17RD 1 LEAD	B5392	1
21	KEY .188 X .188 X 2.000 4140 HT BER	A3255	1
22	GEARCASE MACHINING	D3244	1
23	SHIM .760/.786 X 1.235/1.265 X .018/.024	A4389	2
24	END CAP	B4866	1
25	PIN SLOTTED SPRING .250 X 1.500 STL	A4499	1
26	HANDLE ASSEMBLY	B1015	1
27	HANDLE SOCKET	A10866	1
28	SETSCR SQHD .375-16NC X .500 ZNPL STL	A3725	1
29	PIN COTTER .187 X 1.250 ZNPL STL	A3155	1
30	SEAL OIL .750ID X 1.375OD X .250	A9518	1
31	KEY .500 X .500 X 1.000 4140 HT BES	A10120	2
32	WORM GEAR 8.12OD X 7.750PD X 7.469RD	C4605	1
33	DRUM SHAFT	D3182	1
34	BRG RAD BALL 45MM X 85MM X 19MM	A9968	2
35	FRONT COVER MACHINING	C4378	1
36	SHIM 1.883 X 2.750 X .060 STL	A10124	2
37	SEAL OIL 1.625ID X 2.252 X .313	A9967	1
38	BACK COVER MACHINING	C4377	1
39	CAPSCR HEXHD .375-16NC X 1.500 ZNPL GR5	A3236	4
40	PIN GROOVE TYPE A .500 X 3.750 ALYSTL	A2558	1
41	FRAME WELDMENT	C4379	1
42	BRG FLNG 1.44ID 4 BOLT SETSCR LOCK	A10429	1
43	CAPSCR HEXHD .500-13NC X 2.000 ZNPL GR5	A2894	4
44	PLUG PIPE HEXSOC .500-14NPT X .63 SAE	A3126	1
45	SETSCR SOKHD NYLK .375-16NC X .625	A3128	1
46	DRUM WELDMENT	C4637	1
47	WASHER SPRING .559 X 1.100 X .039 SPR STL	A9846	2
48	O-RING .750 X .875 X .063 NITRILE	A9813	4
49	O-RING .375 X .500 X .063 NITRILE	A9814	2
50	LABEL WARNING DO NOT ADJUST BRAKE UNDER LOAD	A2658	1
51	LABEL WARNING INSTALL WIRE ROPE AS SHOWN	A7406	1
52	LABEL WARNING INSTALL WIRE ROPE AS SHOWN	A10680	1
53	LABEL MODEL/CAPACITY 2W40-L SERIES	A10873	1
54	LABEL WARNING KEEP HANDS AWAY FROM DRUM	A2659	1
55	LABEL NAMEPLATE THERN LOGO	A6889	1
56	LABEL WARNING POINTS 1-10 FOR 4X	A2655	1
57	LABEL DATE OF MANUFACTURE	10477	1

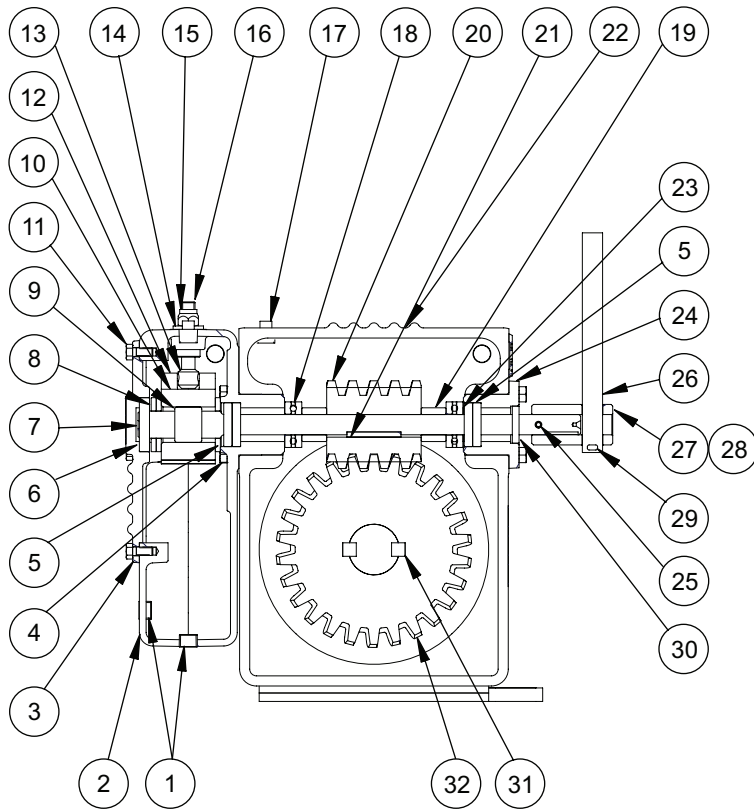

SECTION A-A

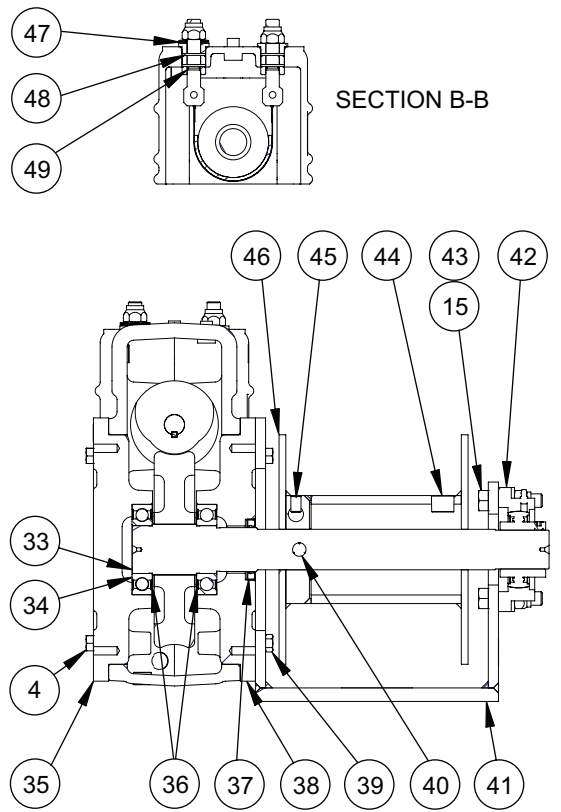

SECTION C-C

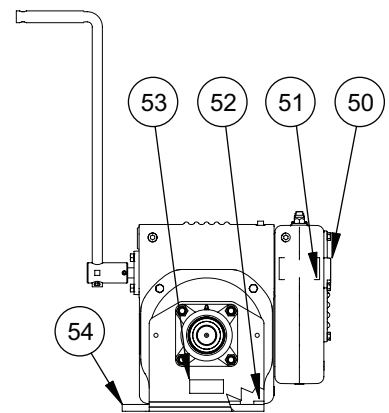
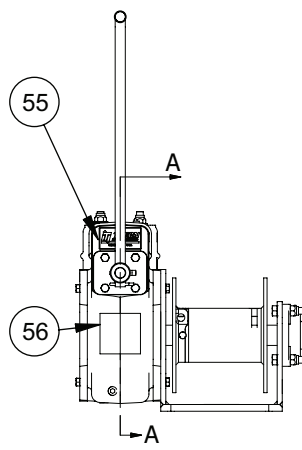
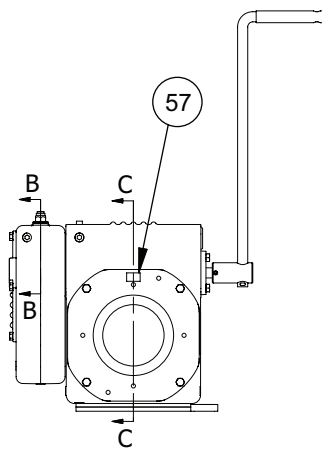

Model 2W40-M

item	description	part number	qty.
1	END CAP	B4866	2
2	CAPSCR HEXHD .375-16NC X 1.000 ZNPL GR5	A2922	12
3	INPUT SHAFT	B5094	1
4	SEAL OIL .750ID X 1.375OD X .250	A9518	2
5	BRG RAD BALL .750ID X 1.625OD X .31W STL	A9793	4
6	PLUG BREATHER .375-18NPT X .48 PLN STL	A3408	1
7	BRG BALL THRUST .753ID X 1.685OD X .625	A1498	2
8	WORM SPACER	A9564	2
9	KEY .188 X .188 X 2.000 4140 HT BER	A3255	1
10	WORM 1.75OD X 1.500PD X 1.22RD 2 LEAD	A1612	1
11	GEARCASE MACHINING	D3244	1
12	SHIM .760/.786 X 1.235/1.265 X .018/.024	A4389	2
13	PLUG PIPE HEXSOC .375-18NPT X .425 SAE	A3290	6
14	PIN SLOTTED SPRING .250 X 1.500 STL	A4499	1
15	HANDLE SOCKET	A10122	1
16	HANDLE ASSEMBLY	B5275	1
17	KEY .500 X .500 X 1.000 4140 HT BES	A10120	2
18	WORM GEAR 8.12OD X 7.750PD X 7.469RD	C4401	1
19	DRUM SHAFT	D3182	1
20	BRG RAD BALL 45MM X 85MM X 19MM	A9968	2
21	FRONT COVER MACHINING	C4378	1
22	SHIM 1.883 X 2.750 X .060 STL	A10124	2
23	SEAL OIL 1.625ID X 2.252 X .313	A9967	1
24	BACK COVER MACHINING	C4377	1
25	CAPSCR HEXHD .375-16NC X 1.500 ZNPL GR5	A3236	4
26	PIN GROOVE TYPE A .500 X 3.750 ALYSTL	A2558	1
27	FRAME WELDMENT	C4379	1
28	BRG FLNG 1.44ID 4 BOLT SETSCR LOCK	A10429	1
29	NUT HEX NYLK .500-13NC ZNPL GR2	A2897	4
30	CAPSCR HEXHD .500-13NC X 2.000 ZNPL GR5	A2894	4
31	PLUG PIPE HEXSOC .500-14NPT X .63 SAE	A3126	1
32	SETSCR SOKHD NYLK .375-16NC X .625	A3128	1
33	DRUM WELDMENT	C4637	1
34	LABEL MODEL/CAPACITY 2W40-M SERIES	A10786	1
35	LABEL WARNING KEEP HANDS AWAY FROM DRUM	A2659	2
36	LABEL NAMEPLATE THERN LOGO	A6889	1
37	LABEL WARNING FOR NON BRAKE WINCHES	A10806	1
38	LABEL DATE OF MANUFACTURE	10477	1

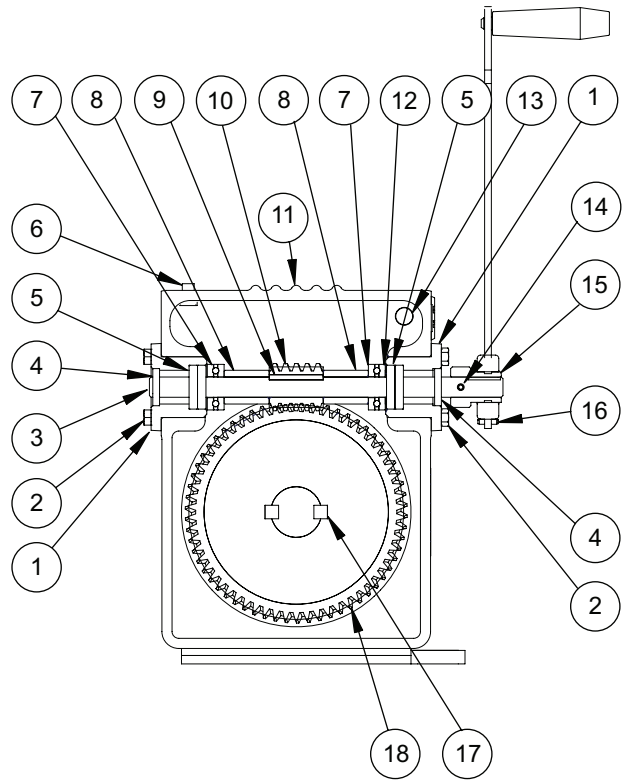

SECTION A-A

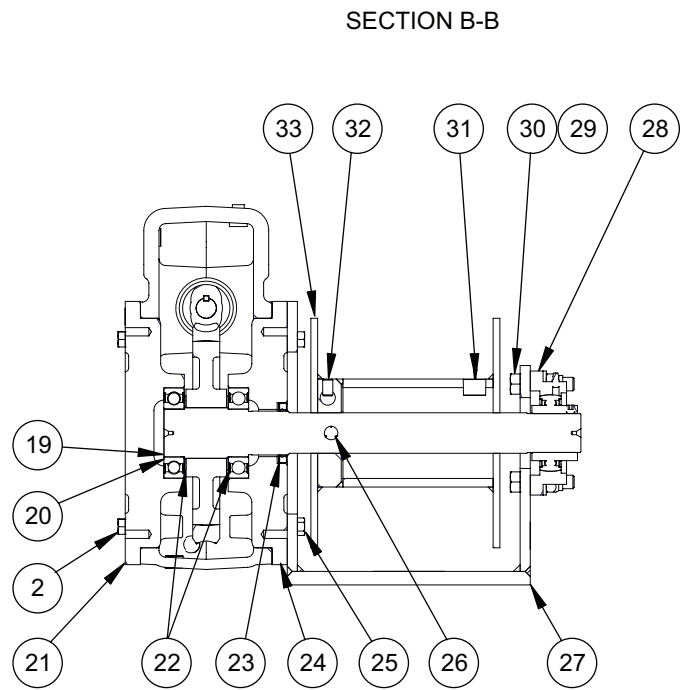

SECTION B-B

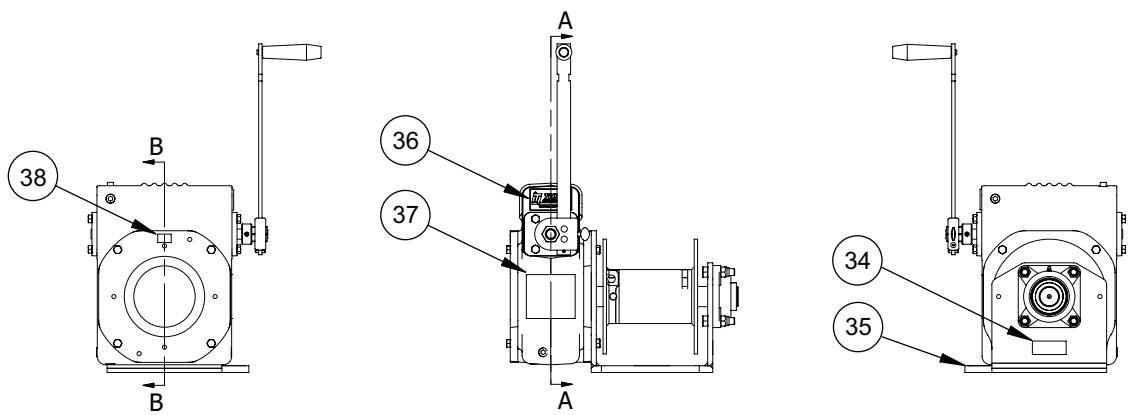

Model 2W40-BM

item	description	part number	qty.
1	PLUG PIPE HEXSOC .375-18NPT X .425 SAE	A3290	12
2	BRAKE HOUSING MACHINING	D3257	1
3	MACHINING COVER BRAKE	C4450	1
4	CAPSCR HEXHD .375-16NC X 1.000 ZNPL GR5	A2922	12
5	BRG RAD BALL .750ID X 1.625OD X .31W STL	A9793	4
6	BRG RAD BALL 1.000 X 2.000 X .375	A2056	1
7	INPUT SHAFT	B4872	1
8	THRUST BEARING	A9804	3
9	BRG CLUTCH 1.000ID X 1.312OD X 1.063 STL	A9844	1
10	BRAKE DRUM	B4995	1
11	CAPSCR HEXHD .312-18NC X .750 ZNPL GR5	A3032	4
12	BRAKE BAND ASSEMBLY	B4991	1
13	PIN DOWEL .250 X 2.000 ALYSTL	A9845	2
14	CONNECTOR BUSHING	A9812	2
15	NUT HEX NYLK .500-13NC ZNPL GR2	A2897	6
16	BRAKE BAND CONNECTOR	A9803	2
17	PLUG BREATHER .375-18NPT X .48 PLN STL	A3408	1
18	BRG BALL THRUST .753ID X 1.685OD X .625	A1498	2
19	WORM SPACER	A9564	2
20	WORM 1.75OD X 1.500PD X 1.22RD 2 LEAD	A1612	1
21	KEY .188 X .188 X 2.000 4140 HT BER	A3255	1
22	GEARCASE MACHINING	D3244	1
23	SHIM .760/.786 X 1.235/1.265 X .018/.024	A4389	2
24	END CAP	B4866	1
25	PIN SLOTTED SPRING .250 X 1.500 STL	A4499	1
26	HANDLE SOCKET	A10122	1
27	HANDLE ASSEMBLY	B5275	1
28	SEAL OIL .750ID X 1.375OD X .250	A9518	1
29	KEY .500 X .500 X 1.000 4140 HT BES	A10120	2
30	WORM GEAR 8.12OD X 7.750PD X 7.469RD	C4401	1
31	DRUM SHAFT	D3182	1
32	BRG RAD BALL 45MM X 85MM X 19MM	A9968	2
33	FRONT COVER MACHINING	C4378	1
34	SHIM 1.883 X 2.750 X .060 STL	A10124	2
35	SEAL OIL 1.625ID X 2.252 X .313	A9967	1
36	BACK COVER MACHINING	C4377	1
37	CAPSCR HEXHD .375-16NC X 1.500 ZNPL GR5	A3236	4
38	PIN GROOVE TYPE A .500 X 3.750 ALYSTL	A2558	1
39	FRAME WELDMENT	C4379	1
40	BRG FLNG 1.44ID 4 BOLT SETSCR LOCK	A10429	1
41	CAPSCR HEXHD .500-13NC X 2.000 ZNPL GR5	A2894	4
42	PLUG PIPE HEXSOC .500-14NPT X .63 SAE	A3126	1
43	SETSCR SOKHD NYLK .375-16NC X .625	A3128	1
44	DRUM WELDMENT	C4637	1
45	WASHER SPRING .559 X 1.100 X .039 SPR STL	A9846	2
46	O-RING .750 X .875 X .063 NITRILE	A9813	4
47	O-RING .375 X .500 X .063 NITRILE	A9814	2
48	LABEL WARNING DO NOT ADJUST BRAKE UNDER LOAD	A2658	1
49	LABEL WARNING INSTALL WIRE ROPE AS SHOWN	A7406	1
50	LABEL WARNING INSTALL WIRE ROPE AS SHOWN	A10680	1
51	LABEL MODEL/CAPACITY 2W40-M SERIES	A10786	1
52	LABEL WARNING KEEP HANDS AWAY FROM DRUM	A2659	1
53	LABEL NAMEPLATE THERN LOGO	A6889	1
54	LABEL WARNING POINTS 1-10 FOR 4X	A2655	1
55	LABEL DATE OF MANUFACTURE	10477	1

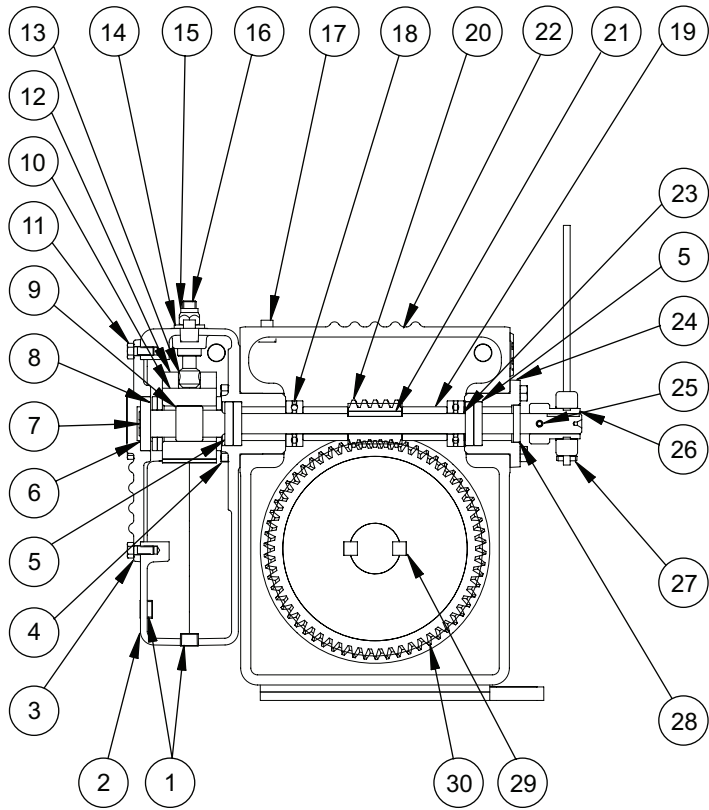

SECTION A-A

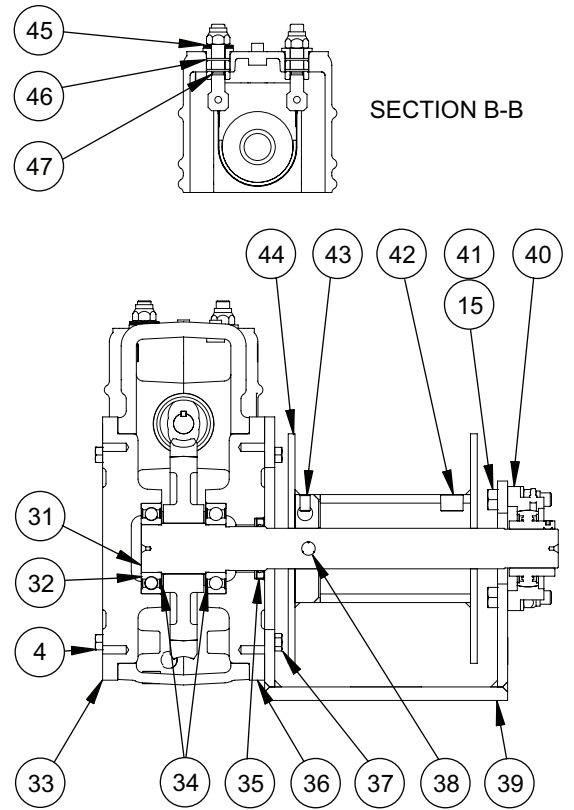

SECTION C-C

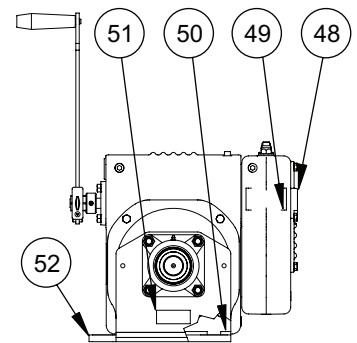
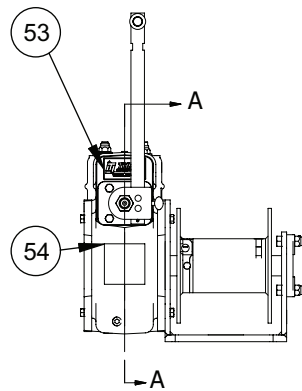
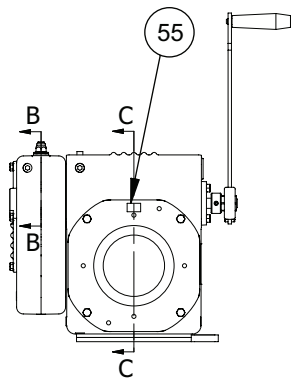



Thern, Incorporated
5712 Industrial Park Road
Winona, MN 55987

PH: 507-454-2996
FAX: 507-454-5282

EMAIL: info@thern.com
www.thern.com

Thern Europe
Siriusdreef 17-27, 2132 WT
Hoofddorp
The Netherlands

PH: +31-546-898-380

EMAIL: europe@thern.com