



Read this Owner's Manual thoroughly before operating the equipment. Keep it with the equipment at all times. Replacements are available from Thern, Inc., Winona, MN 55987, 507-454-2996. www.thern.com

IMPORTANT: Please record product information on page 2. This information is required when calling the factory for service.

ORIGINAL TEXT



Owner's Manual

For
5FT40 and 5FT100 Series Stationary
Davit Cranes

Two-Year Limited Warranty

Please record the following:

Date Purchased: _____

Crane Model No.: _____

Crane Serial No.: _____

If sold with a winch:

Winch Model No.: _____

Winch Serial No.: _____

This information is required when calling the factory for service.

Thern, Inc. warrants its products against defects in material or workmanship for two years from the date of purchase by the original using buyer, or if this date cannot be established, the date the product was sold by Thern, Inc. to the dealer. To make a claim under this warranty, contact the factory for an RGA number. The product must be returned, prepaid, directly to Thern, Inc., 5712 Industrial Park Road, Winona, Minnesota 55987. The following information must accompany the product: the RGA number, the date of purchase, the description of the claimed defect, and a complete explanation of the circumstances involved. If the product is found to be defective, it will be repaired or replaced free of charge, and Thern, Inc. will reimburse the shipping cost within the contiguous USA.

This warranty does not cover any damage due to accident, misuse, abuse, or negligence. Any alteration, repair or modification of the product outside the Thern, Inc. factory shall void this warranty. This warranty does not cover any costs for removal of our product, downtime, or any other incidental or consequential costs or damages resulting from the claimed defects. This warranty does not cover brake discs, wire rope or other wear components, as their life is subject to use conditions which vary between applications.

FACTORY AUTHORIZED REPAIR OR REPLACEMENT AS PROVIDED UNDER THIS WARRANTY IS THE EXCLUSIVE REMEDY TO THE CONSUMER. THERN, INC. SHALL NOT BE LIABLE FOR ANY INCIDENTAL OR CONSEQUENTIAL DAMAGES FOR BREACH OF ANY EXPRESS OR IMPLIED WARRANTY ON THIS PRODUCT. EXCEPT TO THE EXTENT PROHIBITED BY APPLICABLE LAW, ANY IMPLIED WARRANTY OF MERCHANTABILITY OR FITNESS FOR A PARTICULAR PURPOSE ON THIS PRODUCT IS LIMITED IN DURATION TO THE DURATION OF THIS WARRANTY.

Some states do not allow the exclusion or limitation of incidental or consequential damages, or allow limitations on how long an implied warranty lasts, so the above limitation or exclusion may not apply to you. This warranty gives you specific legal rights, and you may also have other rights which vary from state to state.

Note: Thern, Inc. reserves the right to change the design or discontinue the production of any product without prior notice.

About This Manual

The Occupational Safety and Health Act of 1970 states that it is the employer's responsibility to provide a workplace free of hazard. To this end, all equipment should be installed, operated, and maintained in compliance with applicable trade, industrial, federal, state, and local regulations. It is the equipment owner's responsibility to obtain copies of these regulations and to determine the suitability of the equipment to its intended use.

This Owner's Manual, and warning labels attached to the equipment, are to serve as guidelines for hazard-free installation, operation, and maintenance. They should not be understood to prepare you for every possible situation.

The information contained in this manual is applicable only to the Thern Captain Series Model 5FT40 and 5FT100 Stationary Davit Cranes. Do not use this manual as a source of information for any other equipment.

The following symbols are used for emphasis throughout this manual:

▲WARNING

Failure to follow 'WARNING!' instructions may result in equipment damage, property damage, and/or serious personal injury.

▲CAUTION

Failure to follow 'CAUTION!' instructions may result in equipment damage, property damage, and/or minor personal injury.

Important!

Failure to follow 'important!' instructions may result in poor performance of the equipment.

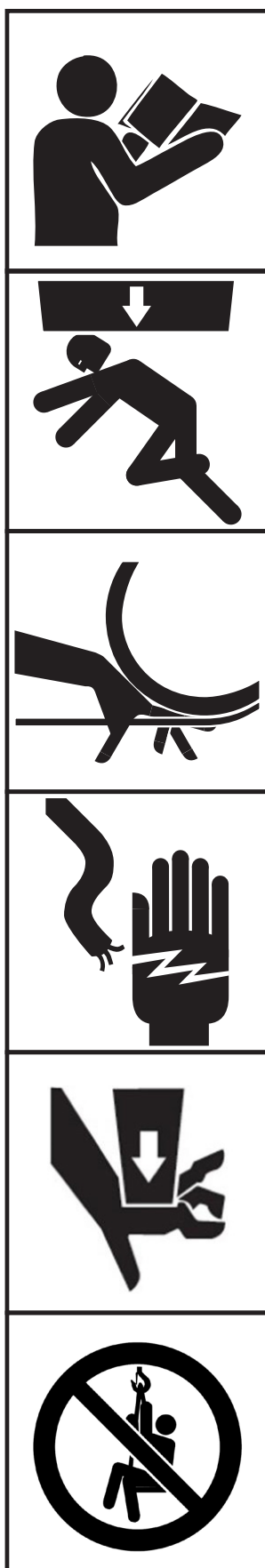

Suggestions for Safe Operation

⚠WARNING

DO the following:

Read and comply with the guidelines set forth in this Owner's Manual. Keep this manual, and all labels attached to the crane, readable and with the equipment at all times. Contact Thern, Inc. for replacements.

Check lubrication before use.

Check for leaks before use.

Install the wire rope securely to the winch drum.

Keep at least 4 wraps of wire rope wound on the drum at all times, to serve as anchor wraps. With less than 4 wraps on the drum the wire rope could come loose, causing the load to escape.

Keep hands away from sheaves, gears, wire rope, and other moving parts. Disconnect any power before servicing the equipment.

Keep all unnecessary personnel away from crane while in operation.

Keep out of the path of the load, and out of the path of a broken wire rope that might snap back and cause injury.

Ensure that both threaded ends of the ratchet jack are threaded an equal distance out of the jack when assembled to the crane. If threaded ends are not equal, the crane boom will not be able to operate in its full range of motion.

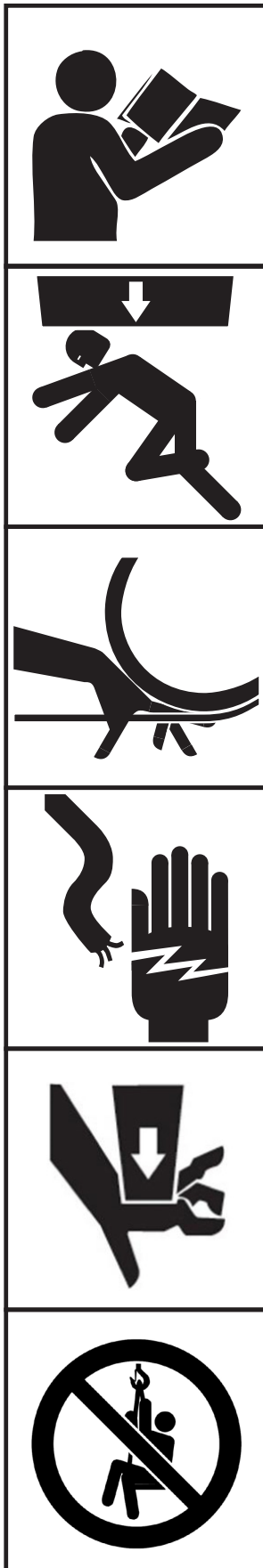

Suggestions for Safe Operation (cont.)

⚠WARNING

DO NOT do the following:

Do not lift people, or things over people. Do not walk or work under a load or in the line of force of any load.

Do not exceed the load rating of the crane or any other component in the system. To do so could result in failure of the equipment.

Do not use more than one crane to move a load that exceeds the load rating of a single crane. A shift in load weight could overload the equipment.

Do not use damaged or malfunctioning equipment. To do so could result in failure of the equipment.

Do not modify the equipment in any way. To do so could cause equipment failure.

Do not wrap the wire rope around the load. This damages the wire rope and could cause the load to escape. Use a sling or other approved lifting device.

Do not operate the crane with guards removed or improperly installed.

Do not divert your attention from the operation. Stay alert to the possibility of accidents, and try to prevent them from happening.

Do not jerk or swing the load. Avoid shock loads by starting and stopping the load smoothly. Shock loads overload the equipment and may cause damage.

Do not use the crane and winch components for any use other than for their original intended function.

Do not use the crane to drag or pull loads. This will create side pulls, which could damage the equipment or cause the load to tip.

Do not leave a suspended load unattended. Place the load on the ground if it must be left unattended.

Do not adjust the winch brake with the load suspended.

Do not operate or apply loads without all pins securely in place.

Do not adjust the boom extension while the crane is loaded.

Do not make adjustments to the ratchet jack while the crane is loaded. To do so may require the use of excessive force which could cause damage or injury.

1.1 Installing the Crane

Important!

- A qualified professional should inspect or design the foundation to insure that it will provide adequate support.
- Locate the crane so it will be visible during the entire operation.

⚠WARNING

Do not install the crane in an area defined as hazardous by the National Electric Code, unless installation in such an area has been thoroughly approved.

Do not install the crane near corrosive chemicals, flammable materials, explosives, or other elements that may damage the crane or injure the operator. Adequately protect the crane and the operator from such elements.

Position the crane so the operator can stand clear of the load, and out of the path of a broken wire rope that could snap back and cause injury.

Attach the crane to a rigid and level foundation that will support the crane and its load under all load conditions, including shock loading.

- 1.1.1 CONSULT APPLICABLE CODES AND REGULATIONS for specific rules on installing the equipment.
- 1.1.2 LOCATE THE CRANE in an area clear of traffic and obstacles that could interfere with operation. Make sure the crane is accessible for maintenance and operation.
- 1.1.3 INSTALL THE CRANE on a level surface.
- 1.1.4 FASTEN THE BASE securely to the foundation to withstand applicable overturning moments and mounting bolt reaction. See Table 1.
 - a FOR STANDARD PRODUCTS referred to in this manual, use coarse thread fasteners, grade 5 or better.

Suggested Fastener Torque Values (ft-lbs)

	Plain & Dry	Zinc Plated	Lubricated (e.g. Loctite)
3/4 inch grade 5	267	227	200
1-1/4 inch grade 5	1121	952	840
M20 grade 8.8	325	276	244
M30 grade 8.8	1116	949	837

Refer to manufacturer's instructions for other fastener types with specific torque or installation instructions.

- b NON-STANDARD PRODUCTS that vary from the original design may have different fastening requirements. Contact a structural engineer or Thern, Inc. for this information.

TO COMPLY WITH LOCAL CODES, CONTACT A QUALIFIED PROFESSIONAL TO OBTAIN PROPER STRUCTURE OR FOUNDATION SPECIFICATIONS FOR THE MOUNTING OF THERN PRODUCTS.

Table 1 - Crane Reactions

Crane Model	Mast Moment		Suggested Bolt Size	Force per Bolt	
	in-lbs	N-m		lbs	N
5FT40	398,100	44,982	3/4 inch (M20)	6,470	28,782
5FT100	1,337,980	151,178	1-1/4 inch (M30)	10,090	44,885

This information may change without prior notice. It is the responsibility of the installer and/or end user to ensure the most current information is used.

1.2 Assembling the Crane

⚠ CAUTION

When installing the ratchet jack, support the end of the boom so the boom does not fall and the ratchet jack does not swing up causing damage or injury.

When installing the boom extension, hold the boom extension securely so it does not slide abruptly in or out of the boom causing damage or injury.

Important!

- Inspect the crane during assembly according to the Instructions for Periodic Inspection. This will give you a record of the condition of the crane with which to compare future inspections.
- Save all boxes and crates that the crane was shipped in, use them again if you need to repackage the crane.
- Contact the factory immediately if any parts are missing or damaged.
- Do not overtighten fasteners, this may strip threads or cause damage to other parts.

Figure 1 – Cotter Pins

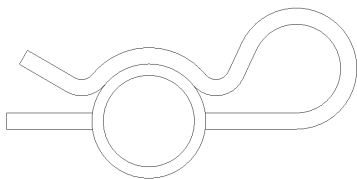

- 1.2.1 STUDY PARTS DRAWINGS to understand how the crane is assembled. See pages 19-23.
- 1.2.2 LUBRICATE THE ENTIRE CRANE as you assemble it. Refer to the Lubrication Instructions in Section 3.2
- 1.2.3 INSTALL THE BASE. See Section 1.1 for additional information and crane overturning moments and mounting bolt reaction forces.
- 1.2.4 INSTALL THE SUPPORT JACK: ratchet style or hydraulic (if equipped).
 - a ENSURE THAT BOTH THREADED ENDS of the ratchet jack are an equal distance out of the jack when assembled to the crane. If threaded ends are not equal, the crane boom will not be able to operate in its full range of motion.
 - b FASTEN ONE END OF THE RATCHET JACK to the mounting ear on the mast with clevis and cotter pin provided. See Figure 1
- 1.2.5 FASTEN THE BOOM to the mast using the clevis and cotter pin provided. **For manual winch models, install a sheave on the boom pin as you fasten the boom to the mast.**
- 1.2.6 POSITION THE BOOM carefully so the other end of the support jack aligns with the mounting ear and secure using the clevis and cotter pin provided.
- 1.2.7 ADJUST THE BOOM with the support jack so the boom is horizontal.
- 1.2.8 SLIDE THE BOOM EXTENSION into the boom, and secure in place with the clevis pin and cotter pin provided. **Make sure the boom extension is positioned correctly with auxiliary mounting holes toward the ground.**
- 1.2.9 FASTEN THE WINCH to the appropriate mounting plate. Manual winches should be installed on the mast. Power winches should mount on the boom.
- 1.2.10 INSTALL THE WINCH HANDLE on hand winches, or connect electric current on power winches. Refer to instructions in the Winch Owner's Manual.
- 1.2.11 INSTALL THE WIRE ROPE.
 - a REMOVE ROPE KEEPER PIN at the sheave to allow rope to be installed.
 - b PASS THE WIRE ROPE over the sheave and reinstall rope keeper pin to prevent the rope from escaping the sheave rope groove.
 - c ANCHOR THE WIRE ROPE to the winch drum and wind 4 wraps of wire rope onto the drum to act as anchor wraps. Refer to the instructions in the Winch Owner's Manual.
- 1.2.12 MAKE SURE ALL FASTENERS are tightened with all clevis and cotter pins in place to prevent components from shifting during use.
- 1.2.13 INSTALL UPPER TRAVEL LIMIT SWITCH when supplied with power winches as directed in supplemental instructions provided with limit switch.

Important!

- Limit non-uniform winding by keeping tension on the wire rope.
- It is your responsibility to detect and account for different factors affecting the condition and performance of the equipment.

2.1 General Theory of Operation

- 2.1.1 THE INTENDED USE of this machinery is to lift and lower loads of its rated capacity or less. It is not for lifting people or things over people.
- 2.1.2 THE FORCE REQUIRED to lift the load must not exceed the load rating of the crane. Consider the total force required to lift the load, not the weight of the load.
- 2.1.3 THIS EQUIPMENT CAN develop forces that will exceed the load rating. It is the responsibility of the equipment user to limit the size of the load. Inspect the equipment regularly for damage according to the instructions contained in this manual.
- 2.1.4 PERFORMANCE RATINGS of the equipment are affected by the position of the boom, and the amount of wire rope you use. **Crane load ratings decrease as you extend the reach.** See the Performance Characteristics Tables on pages 25-26.
- a LOAD RATING represents the maximum force that can be placed on new equipment. Load ratings are assigned values for specific boom positions and wire rope lengths.
- b LIFT varies with the position of the boom, the length of the wire rope.
- c REACH varies with the position of the boom.
- 2.1.5 DUTY RATINGS refer to the type of use the equipment is subject to. Consider the following when determining duty rating.
- a ENVIRONMENT: harsh environments include hot, cold, dirty, wet, corrosive, or explosive surroundings. **Protect the equipment from harsh environments when possible.** Operating temperature range with manual spur gear winches is -40°F to +122°F. Operating temperature range for standard power winches is -4°F to 104°F.
- b MAINTENANCE: poor maintenance, meaning poor cleaning, lubrication, or inspection, leads to poor operation and possible damage of the equipment. **Minimize poor maintenance by carefully following the instructions contained in this manual.**
- c LOADING: severe loading includes shock loading and lifting loads that exceed the load rating of the equipment. **Avoid shock loads, and do not exceed the load rating of the equipment.**
- d FREQUENCY OF OPERATION: frequent or lengthy operations increase wear and shorten the life span of gears, bearings, sheaves, and other components. **Increase maintenance of the equipment if used in frequent operations.**
- 2.1.6 AIRBORNE NOISE EMISSIONS vary depending on load and the type of winch being used. Standard configurations do not typically exceed a sound pressure level of 80 dB(A) at workstations.
- 2.1.7 VIBRATION LEVELS vary depending on load and type of winch being used. Standard configurations do not typically exceed vibration levels of 2.5 m/s².

CONTACT THE FACTORY FOR MORE INFORMATION.

Important!

When determining whether the load will exceed the load rating, consider the total force required to move the load.

Figure 2 – Positioning the Boom

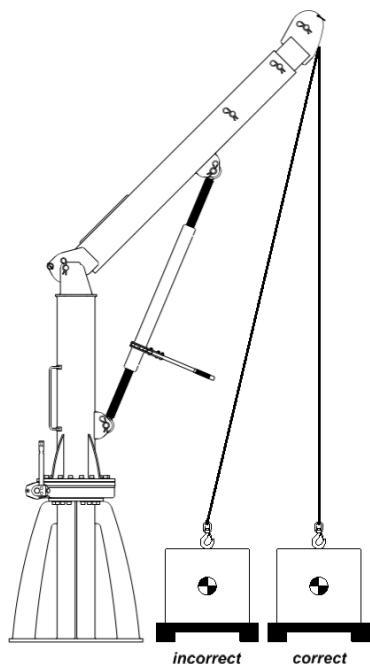
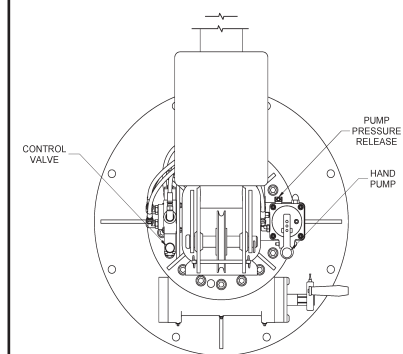

Figure 3 – Pump Pressure Release



2.2 Preparing for Operation

⚠️WARNING

Do not make adjustments to the ratchet jack while the crane is loaded. To do so may require the use of excessive force which could cause damage or injury.

Do not adjust the boom extension while the crane is loaded.

⚠️CAUTION

When adjusting boom length, set the boom angle just above the lowest angle and hold the boom extension securely so it does not slide abruptly in or out of the boom causing damage or injury.

- 2.2.1 CONSIDER THE OPERATION. Do not begin until you are sure you can perform the entire operation without hazard.
- 2.2.2 INSPECT ALL COMPONENTS of the system.
- INSPECT THE CRANE and other equipment according to the Instructions for Frequent Inspection.
 - INSPECT THE WINCH according to the instructions in the Winch Owner's Manual.
 - OPERATORS must be in good health, alert, thoroughly trained in operating the equipment, and properly clothed (hard hat, safety shoes and safety glasses, no loose clothing).
 - THE LOAD must be clear of other objects and free to move. Make sure the load will not tip, spin, roll away, or in any way move uncontrollably.
- 2.2.3 KNOW YOUR LOAD and make sure you do not exceed the load rating of the crane or any other equipment in the system.
- 2.2.4 POSITION THE BOOM so the load hook is centered over the load. **Avoid side pulls which could damage the crane or cause the load to tip. See Figure 2.**
- ADJUST BOOM LENGTH by moving the boom extension in or out. **Do not make adjustments while the crane is loaded. The load rating decreases as you increase boom length. See the Performance Characteristics Tables on pages 25-26.**
 - ADJUST BOOM ANGLE by operating the ratchet jack to raise or lower the boom. **The lift height below base level decreases as you raise the boom. See the Performance Characteristics Tables on pages 25-26.**
- 2.2.5 TO OPERATE HYDAULIC SUPPORT JACK if equipped, follow these steps:
- MOVE THE LEVER on the control valve to the desired BOOM UP or BOOM DOWN position. Operate the hand pump handle to extend or retract the cylinder. **See Figure 3.**
 - WHEN THE DESIRED boom angle has been reached, set the control valve lever in the NEUTRAL position. This will prevent the accidental lifting or lower of the boom.
 - PUMP PRESSURE RELEASE on the hand pump should be in the closed position at all times. Opening the pressure release will result in being unable to lift the boom. **DO NOT ADJUST while the crane is under load.**

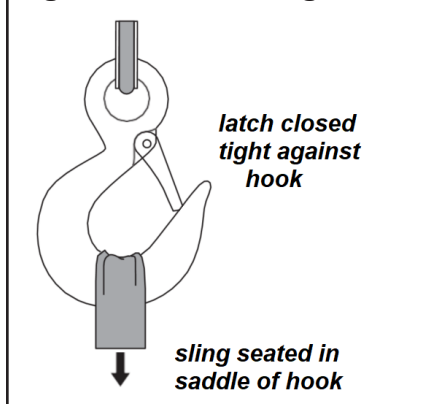
Figure 4 – Attaching Load

2.3 Attaching the Load

⚠WARNING

Do not wrap the wire rope around the load. This damages the wire rope and could cause the load to escape. Use a sling or other approved lifting device.

- 2.3.1 CLEAR OBJECTS from the path of the load so you can move it freely and observe it at all times during the operation.
- 2.3.2 MAKE SURE THE WIRE ROPE is not twisted. A twisted wire rope could cause the load to spin when it is raised off the ground.
- 2.3.3 ATTACH THE LOAD using a nylon sling, or other approved lifting device. Follow the recommendations of the sling manufacturer.
 - a SEAT THE SLING in the saddle of the hook with the hook latch completely closed. See Figure 4.
 - b CENTER THE LOAD on the hook so it will remain balanced and not tip or rotate to one side.

2.4 Moving the Load

⚠WARNING

Do not make adjustments to the ratchet jack while the crane is loaded. To do so may require the use of excessive force which could cause damage or injury.

- 2.4.1 MOVE THE LOAD slowly and smoothly, only a small distance at first. Make sure the load is balanced and securely attached before continuing.
- 2.4.2 OPERATE THE WINCH to raise or lower the load. Refer to the instructions in the Winch Owner's Manual.
- 2.4.3 OBSERVE THE WIRE ROPE as it winds onto the drum. If it becomes loose, uneven, or overlapped, stop the operation and rewind the wire rope before continuing. **Continued operation with overlapped or uneven wire rope can damage the wire rope and shorten its life.**
- 2.4.4 OPERATE THE SUPPORT JACK if necessary, to adjust the angle of the boom to keep the sheave centered over the load.
 - a USE CAUTION WHEN ADJUSTING while the crane is loaded. Do not exceed the load rating for the lowest boom angle range being used. **See the Performance Characteristics tables on page 25-26.**
- 2.4.5 ROTATE THE MAST AND BOOM to move the load side-to-side.
 - a ROTATE THE BOOM slowly and smoothly to avoid swinging the load or causing shock loads. **Do not jam the boom against other objects.**
 - b CLEAR THE PATH of the load so you can move it freely and observe it at all times during the operation.
 - c TO MOVE THE LOAD to the right, rotate the slew drive handle counter-clockwise; to move the load to the left, rotate the slew drive handle clockwise.

Important!

- Obey a stop signal from anyone.
- Maintain tension on the wire rope to keep it tightly and evenly wound on the drum.
- If the crane and load are not visible during the entire operation, get help from another person.
- Appoint a supervisor if more than one person is involved in the operation. This will reduce confusion and increase safety.
- When lifting a load, use a tag line to keep the load from swinging or twisting, while keeping yourself away from the load.

3.1 Cleaning the Crane

Important!

Increase the frequency of maintenance procedures if the crane is:

- Operated for long periods.
- Used to lift heavy loads.
- Operated in wet, dirty, hot, or cold surroundings.

Clean the crane to remove dirt and help prevent rust and corrosion.

- 3.1.1 CLEAN THE CRANE every six months or whenever it is dirty.
 - a WIPE ALL EQUIPMENT to remove dirt and grease.
 - b LEAVE A LIGHT FILM of oil on all surfaces to protect against rust and corrosion.
 - c WIPE OFF excessive amounts of oil to avoid the accumulation of dirt.
- 3.1.2 REMOVE UNNECESSARY OBJECTS from the area surrounding the crane.

Important!

- Make sure lubricant has temperature rating appropriate for the ambient temperatures of the operation.

3.2 Lubricating the Crane

Lubricate the crane properly to help protect it from wear and rust. Read the following instructions carefully.

- 3.2.1 LUBRICATE ALL PINS before installation and at least every 3 months. Use a grease brush to apply a light film of NLGI #2 grease to all pins.
- 3.2.2 LUBRICATE THE SLEW DRIVE BEARING located at the mast before installation and at least every 3 months. Use a grease gun to apply NLGI #2 grease to the grease fittings shown in Figure 5.
- 3.2.3 LUBRICATE THE RATCHET JACK before installation and at least every 3 months. Use a grease gun to apply NLGI #2 grease to the grease fittings on the ratchet jack until excess grease can be seen. Wipe away any excess lubricant.
- 3.2.4 LUBRICATE THE WINCH. Refer to the Winch Owner's Manual for instructions.
- 3.2.5 LUBRICATE THE WIRE ROPE and other equipment by following the manufacturer's recommendations.

Figure 5 – Slew Bearing

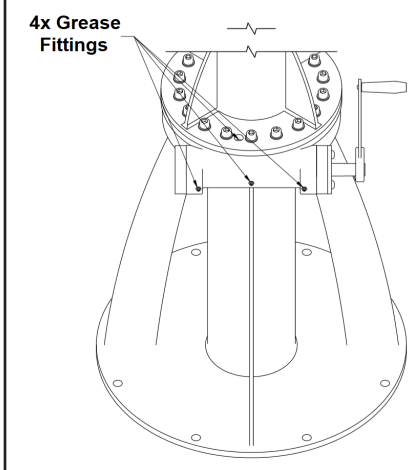

3.3 Disassembling the Crane

⚠ CAUTION

When removing the boom extension, hold the boom extension securely so it does not slide abruptly in or out of the boom causing damage or injury.

When removing the ratchet jack, support the end of the boom so the boom does not fall and the ratchet jack does not swing up causing damage or injury.

- 3.3.1 STUDY PARTS DRAWINGS to understand how the crane is assembled. See pages 19-23.
- 3.3.2 REMOVE ANY ATTACHED LOAD from the wire rope.
- 3.3.3 REMOVE THE WIRE ROPE
 - a REMOVE THE ROPE KEEPER PINS located at the ends of the boom.
 - b UNWIND THE ROPE from the winch drum and release the anchor.
 - c REPLACE THE ROPE KEEPER PINS
- 3.3.4 REMOVE THE WINCH HANDLE on hand winches, or disconnect power supply on power winches. Refer to instructions in the Winch Owner's Manual.
- 3.3.5 REMOVE THE WINCH from the crane.
- 3.3.6 REMOVE THE BOOM EXTENSION.
 - a ADJUST THE BOOM ANGLE using the support jack so the boom is horizontal.
 - b SECURE THE BOOM EXTENSION then remove the cotter pin and clevis pin securing the boom extension to the boom.
 - c CAREFULLY PULL THE BOOM EXTENSION out of the boom, then reinstall the clevis pin and cotter pin in the boom.
- 3.3.7 REMOVE THE SUPPORT JACK.
 - a SECURE THE BOOM to prevent it from falling when the ratchet jack is released.
 - b DISCONNECT THE SUPPORT JACK at the mast by removing the cotter pin and clevis pin. Be careful that the ratchet jack does not swing and cause injury.
 - c REMOVE THE PIN AT THE BOOM to disconnect the support jack from the crane. Hold onto the support jack to prevent it from falling away.
 - d RECONNECT the clevis pins to the boom and mast with the appropriate cotter pins.
- 3.3.8 DISCONNECT THE BOOM from the mast.
 - a SECURE THE BOOM to prevent it from falling away when the pins are removed.
 - b REMOVE THE COTTER PIN AND CLEVIS PIN and carefully remove the boom.
 - c REPLACE the clevis pin and cotter pin in the mast.

3.4 Inspecting the Equipment

⚠WARNING

Do not use damaged or malfunctioning equipment. Place an “OUT OF ORDER” sign on the crane. Do not use the crane until the sign is removed by a qualified person who has completely corrected the problem.

Inspect the crane to detect signs of damage or poor operation before they become hazardous. See Table 2 Inspection Checklist.

Important!

- Start an inspection program as soon as you put the crane into use.
- Appoint a qualified person to be responsible for all repairs to the equipment.
- Keep written records of inspection. This allows comparison with comments from previous inspections so you can see changes in condition or performance.

Perform frequent inspections:

- Before each operation.
- Every 3 hours during operation.
- Whenever you notice signs of damage or poor operation.

Frequent Wire Rope Inspection:

- Use ASME B30.7 as a guideline for rope inspection, replacement and maintenance.
- Check the wire rope, end connections and end fittings for corrosion, kinking, bending, crushing, birdcaging or other signs of damage.
- Check the number, distribution and type of visible broken wires. See paragraph 3.4.4 b and Figure 5.
- Check the wire rope for reduction of rope diameter from loss of core support, or wear of outside wires. See Figure 7.
- Take extra care when inspecting sections of rapid deterioration such as sections in contact with saddles, sheaves, repetitive pickup points, crossover points and end connections.

3.4.1 **CONSULT APPLICABLE CODES AND REGULATIONS** for specific rules on inspecting the crane and other equipment.

3.4.2 **REFER TO THE WINCH OWNER’S MANUAL** for information regarding winch inspection.

3.4.3 **Instructions for Frequent Inspection**

a **VISUALLY INSPECT** the entire crane and all other equipment involved in the operation.

- Check all equipment for cracks, dents, bending, rust, wear, corrosion and other damage.
- Make sure the wire rope is installed correctly and anchored securely.
- Make sure the entire crane is properly lubricated.
- Make sure all fasteners are tight and secure.
- Make sure mounting fasteners are tightened securely.
- Check the support jack for signs of leakage or damage, and make sure it operates smoothly to raise and lower the boom.
- Make sure the foundation is in good condition, and capable of supporting the crane and its load under all load conditions.

b **TEST CRANE PERFORMANCE** by operating the crane with a load not exceeding the load rating.

- Listen for unusual noises, and look for signs of damage as you operate the crane.
- Make sure the wire rope winds evenly and tightly onto the drum. If it is loose or uneven, rewind it before continuing.
- Make sure the load moves smoothly, without hesitation or strain.
- On hand operated models, make sure the winch handle rotates freely in both directions.
- On power operated models, make sure the winch responds to the control device. It must rotate as shown on the control labels, and it must turn off when you release the control.
- Make sure the boom rotates freely when you push the handle, and remains stationary when you release it.
- Check the winch brake. Raise the load, then lower it and stop it a few feet off the ground. If the load continues to coast or creep under normal operating conditions, the brake may be worn and in need of repair or replacement. Contact the factory.

Completely correct all problems before continuing. Use the Troubleshooting Chart to help determine the cause of certain problems. See Table 3.

Perform periodic inspections:

- Every 6 months.
- Whenever you return the crane to service from storage.
- Whenever you notice damage or poor operation in a frequent inspection.
- Whenever you have, or think you may have, overloaded or shock loaded the crane.

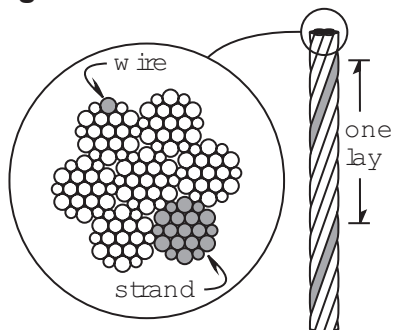
Figure 6 – Broken Wires

Wire rope assembly must be replaced if more than 6 wires are broken in one lay, or if more than 3 wires are broken in one strand in one lay.

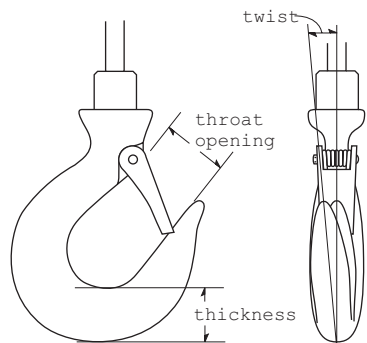
Figure 7 – Load Hook Inspection

The wire rope assembly must be replaced if the throat opening is 15% wider than nominal, if the thickness is 10% less than nominal, or if the hook is twisted 10° or more.

3.4.4 Instructions for Periodic Inspection

- a VISUALLY INSPECT the crane and all other equipment.
 - Disassembly may be required in order to properly inspect individual components. Contact factory for assembly/disassembly instructions. **Disassembly of the winch or crane before contacting Thern, Inc. voids all warranties.**
 - Check the finish for wear, flaking, or other damage.
 - Check all equipment for cracks, dents, bending, rust, wear, corrosion and other damage. If the equipment was overloaded, or if you notice cracks and other signs of overloading and damage, promptly remove equipment from use and have it repaired or replaced. **DO NOT CONTINUE TO USE DAMAGED OR OVERLOADED EQUIPMENT OR WIRE ROPE.**
 - Check all fasteners for stripped threads, wear, bending, and other damage.
 - Make sure the entire crane is properly lubricated.
 - Check the support jack for signs of leakage or damage, and make sure it operates smoothly to raise and lower the boom.
 - Remove the ratchet jack from the crane assembly. Test the travel limits of the ratchet jack. Make sure it does not fully un-thread.
 - Make sure all labels and plates are readable, firmly attached, free of damage and clean. Replacements are available from the factory.
- b INSPECT THE WIRE ROPE according to the wire rope manufacturer's recommendations, or follow accepted industry standards for wire rope inspection.
 - Always wear protective clothing when handling wire rope.
 - Check the entire length of wire rope for bent wires, crushed areas, broken or cut wires, corrosion, and other damage. Carefully inspect areas that pass over sheaves or through roller guides.
 - Note the location and concentration of broken wires. Replace wire rope if more than 6 wires are broken in one lay, or more than 3 wires are broken in one strand in one lay. See Figure 6.
 - Make sure the load hook or other device is securely attached to the wire rope, and the wire rope where it is attached is not frayed, corroded, broken, or otherwise damaged.
 - Measure the throat opening, thickness, and twist of the hook. Replace the hook if it shows signs of damage. See Figure 7.
 - Make sure hook latch opens without binding and closes when released.
 - Check the anchor holes in the drum and the surrounding area for signs of wear or distortion.
- c PLACE enough weight to keep the wire rope straight and tightly drawn.
 - Measure the diameter of the wire rope, especially in areas where wear is noticeable. Replace the wire rope if the diameter measures below the minimum diameter at any point. See Figure 8.
- d REMOVE THE WINCH and inspect it by following the instructions in the Winch Owner's Manual.
- e INSPECT THE BASE FOUNDATION for damage.
 - Check fasteners for stripped threads, wear, bending, and other damage.
 - check the foundation for cracks, corrosion, and other damage.

Figure 8 – Rope Diameter

The wire rope assembly must be replaced if the diameter measures less than the minimum diameter at any point.

wire rope size	minimum diameter
5/16 in	19/64 in (.2969 in)
3/8 in	11/32 in (.3438 in)
7/16 in	13/32 in (.4063 in)
1/2 in	15/32 in (.4688 in)
9/16 in	33/64 in (.5156 in)
5/8 in	37/64 in (.5781 in)

- r TEST CRANE PERFORMANCE by operating the crane with a load equal to the load rating.
 - Listen for unusual noises, and look for signs of damage as you operate the crane.
 - Make sure the wire rope winds evenly and tightly onto the drum. If it is loose or uneven, rewind it before continuing.
 - Make sure the load moves smoothly, without hesitation or strain.
 - On hand operated models, make sure the winch handle rotates freely in both directions.
 - On power operated models, make sure the winch responds to the control device. It must rotate as shown on the control labels, and it must turn off when you release the control.
 - Make sure the boom rotates freely when you rotate the slew drive handle.
 - Check the brake. Raise the load, then lower it and stop it a few feet off the ground. If the load continues to coast or creep under normal operating conditions, the brake may be worn and in need of repair or replacement. Contact the factory.

Completely correct all problems before continuing. Use the Troubleshooting Chart to help determine the cause of certain problems. See Table 3.

Table 3 – Troubleshooting Chart

problem	cause	correction
overheating	<ul style="list-style-type: none"> • operated too long without rest. • load too heavy • poor lubrication. • bearing seized up 	<ul style="list-style-type: none"> allow to cool lighten load inspect and lubricate as necessary inspect and replace as necessary
boom bounces up and down	<ul style="list-style-type: none"> • load too heavy • mounting bolts loose • sheave worn or damaged. • foundation loose or unlevel • winch gears worn or damaged 	<ul style="list-style-type: none"> lighten load tighten mounting bolts to proper torque inspect and replace as necessary inspect and repair as necessary inspect and repair as necessary
boom does not rotate	<ul style="list-style-type: none"> • rotation points contaminated or worn • flange bearing broken or locked. 	<ul style="list-style-type: none"> inspect and repair as necessary inspect and replace as necessary
boom rotates on its own	<ul style="list-style-type: none"> • foundation loose or unlevel • mast bent, distorted, or leaning. 	<ul style="list-style-type: none"> inspect and repair as necessary inspect and repair as necessary
unusual noises		
high pitched squeak	• poor lubrication.	lubricate entire crane properly
grinding noise	• contaminated lubricant at rotation points	clean and lubricate rotation points
rattling noise	• loose bolts, set screws or other fasteners.	tighten all bolts and other fasteners
resistance felt in ratchet jack - boom not able to raise or lower to the published angle limits	• threaded ends of ratchet jack do not protrude equally from the jack	Adjust the threaded rod ends by removing the jack and turning the ends until an equal amount of threads are showing
ratchet jack fully un-threads	• travel limit pin damaged	contact Thern

Refer to the Winch Owner's Manual for possible problems with the winch and brake.

3.5 Repairing the Crane

Important!

- It is your responsibility to determine when to replace parts. When considering whether to continue using a part or to replace it, remember that replacing it is the best way to avoid further equipment damage.
- Appoint a qualified person to be responsible for all repairs to the equipment.

- 3.5.1 GET FACTORY AUTHORIZATION for all repairs. Unauthorized repairs will void the warranty, and may lead to damage or failure of the crane.
- 3.5.2 REPLACE DAMAGED OR POORLY OPERATING PARTS with Thern repair parts.
- 3.5.3 REFINISH AREAS where the paint is worn or flaking. A good finish helps to protect against corrosion and weather damage.
- REMOVE THE FINISH from damaged areas, down to the bare metal.
 - CLEAN THE AREA thoroughly.
 - REPAINT with a high quality primer and finishing coat.
- 3.5.4 TO ORDER REPAIR PARTS, contact your local dealer. Include the following information when ordering:
- model number
 - serial number (or code number)
 - part number
 - product finish (enamel, epoxy, galvanized, etc.)
 - date purchased, and from whom
 - description of what happened, or what is wrong
 - your name and return address

Table 4 – Crane Weight Chart

Component	Model 5FT40		Model 5FT100	
	LB	KG	LB	KG
Mast Assembly	686 *	(311.2)*	1624	(736.6)
Boom Assembly	167	(75.8)	470	(213.2)
Boom Ext Assembly	125	(56.7)	353	(160.1)
Support Jack	46	(20.9)	134	(60.8)
TOTAL	1024 *	(464.6) *	2581	(1170.7)
Winch	LB	KG	LB	KG
M452B-K	77	(35.0)	77	(35.0)
M492B	-	-	162	(73.5)
2W40V-BM-K	122	(55.4)	-	-
3WG4B-K	192	(87.1)	-	-
3WG4MT-K	202	(91.6)	-	-
4HWF6M-KL	478	(216.8)	478	(216.8)
4HBN7M-KL	-	-	546	(247.7)

*Add 40 lbs (18.2 kg) for hydraulic jack system.

3.6 Field Test Procedure

⚠CAUTION

Use the following instructions to perform a pre-service load test on new, undamaged, and unaltered equipment only. **For field testing of existing in-service equipment, do not exceed 100% rated capacity.**

- 3.6.1 VISUALLY INSPECT the product for any signs of wear, damage, or deformation. **Do not apply test loads until problems have been corrected.**
- 3.6.2 ASSEMBLE THE CRANE according to the instructions found within the owner's manual.
- 3.6.3 OPERATE THE CRANE, without load, through its designed range of motion. The product should operate smoothly, braking systems of power driven components operate effectively, and motion limiting devices are adjusted and functioning properly. **Do not continue until problems have been corrected.**
- 3.6.4 PREPARE A TEST LOAD with a load sensing device.
- 3.6.5 FOR MAXIMUM DYNAMIC LOAD TEST, load the crane to 110% of its rated capacity and operate the crane through its designed range of motion while checking for signs of damage.
 - a SLOWLY RELEASE THE LOAD and visually inspect the product for signs of wear, damage, or deformation. **Do not continue until problems have been corrected.**
- 3.6.6 FOR MAXIMUM STATIC LOAD TEST, load the crane to 125% of its rated capacity and hold for 10 minutes while checking for signs of damage. Do not exceed 125% of rated capacity.
 - a SLOWLY RELEASE THE LOAD and visually inspect the product for signs of wear, damage, or deformation. **Do not continue until problems have been corrected.**
- 3.6.6 OPERATE THE CRANE, without load, through its designed range of motion to confirm no failures.

Tests are considered successful if no fractures, permanent deformations, or damage affecting the function or safety of the crane are visible and if no connections have loosened or show signs of damage.

4.1 Transporting the Crane

Important!

- Keep a record of what you ship, and when you send it.

- 4.1.1 PARTIALLY DISASSEMBLE THE CRANE into components that can be transported.
- 4.1.2 PACK THE CRANE for transport, using the original packaging materials, if appropriate.
- 4.1.3 PACK THE WINCH for transport, using the original packaging materials, if appropriate. Please see the winch owner's manual for instructions.
- 4.1.4 REASSEMBLE THE CRANE at its new location following the instructions under Section 1.2 - Assembling the Crane.
- 4.1.5 INSPECT THE CRANE according to the Instructions for Frequent Inspection before installing it for operation. See Section 3.4.3 - Instructions for Frequent Inspection.

4.2 Storing the Crane

- 4.2.1 PARTIALLY DISASSEMBLE THE CRANE and store all parts in a cool clean place away from corrosive chemicals and moisture.
- 4.2.2 SEAL THE CRANE in plastic with a desiccant to help protect it from rust, corrosion, and other damage.
- 4.2.3 SEAL THE WINCH in plastic with a desiccant to help protect it from rust, corrosion, and other damage. Please see the winch owner's manual for instructions.
- 4.2.4 REASSEMBLE THE CRANE at its new location according to Section 1.2 - Assembling the Crane.
- 4.2.5 INSPECT THE CRANE according to Section 3.4.4 - Instructions for Periodic Inspection before installing it for operation.

Model 5FT40

item	description	part number	qty.
1	WELDMENT BASE 5FT40	A27438 *	1
2	DRIVE SLEWING WE12 MANUAL	A27164 *	1
3	CAPSCR SOKHD M16-2.0 X 50MM M567 12.9	A13915	34
4	WASHER FLT M16 X 30MM X 3.3MM M567	A11710	34
5	WELDMENT MAST 5FT40 SJ	A27437 *	1
6	WELDMENT BOOM 5FT40	A27439 *	1
7	WELDMENT BOOM EXT 5FT40	A27440 *	1
8	JACK RATCHET 1.75 X 38.5-62.0	A27557AGAL	1
9	PIN CLEVIS 1.688 X 3.125 EFF LENGTH SST	A9501	2
10	PIN CLEVIS 1.250 X 2.625 EFF LENGTH SST	A20174	1
11	PIN CLEVIS 1.250 X 5.500 EFF LENGTH SST	A7258	2
12	PIN HAIR COTTER .88/1.25 X .177 DIA SST	A9507	6
13	PIN CLEVIS 1.250 X 7.500 EFF LENGTH SST	A27491	1
14	PIN HEADLESS .375 X 6.000 EFF LENGTH SST	A27492	1
15	PIN LINCH .188 X 1.000 SST	A12416	2
16	PIN LINCH D .250 X 2.500 SST	A13549	1
17	SHEAVE ASSY .50 GR X 1.250 ID X 6.88 OD	A27490	2
18	PLUG FINISH RND .875 X 14-20GA BLK	A25168	1
19	RING RET EXT 1.250 SST	A3892	1
20	WASHER FLT SM OD 1.250 X 2.750 X .116 SST	A21430	1
21	O-RING 3.239 X 3.279 X .070 BUNA-N 70	A27358	1
22	PLATE BRG SLEW DRIVE INPUT	A27179	1
23	SEAL OIL 1.250ID X 1.500OD X .125	A5295	1
24	CAPSCR SOKBTNHD M12-1.75 X 20MM SST A4	A13275	2
25	KEY 8MM X 7MM X 30MM 4140 HT BES	A10098	1
26	SHAFT SLEW DRIVE INPUT	A27493	1
27	HANDLE MEDALLION ASSEMBLY	B4217	1
28	LABEL NAMEPLATE CRANES CE	A11529	1
29	LABEL 5FT40 LOAD RATING	A28264	1
30	LABEL THERN 1.65 X 5.46	A6888	2
31	LABEL CAPTAIN	B7327	2
32	LABEL SHEET SET 5FT40	A27555	1

* Specify finish when ordering.

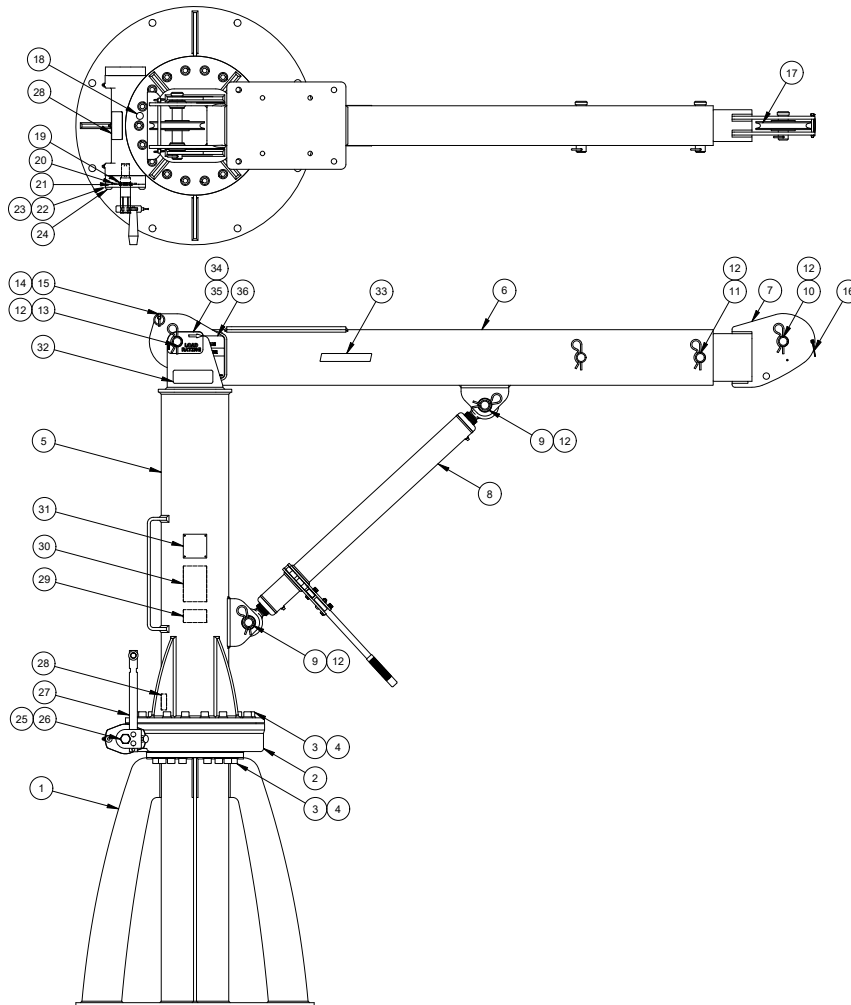

Model 5FT40H

item	description	part number	qty.
1	WELDMENT BASE 5FT40	A27438	1
2	DRIVE SLEWING WE12 MANUAL	A27164	1
3	CAPSCR SOKHD M16-2.0 X 50MM M567 12.9	A13915	34
4	WASHER FLT M16 X 30MM X 3.3MM M567	A11710	34
5	WELDMENT MAST 5FT40 HJ	A27610	1
6	WELDMENT BOOM 5FT40 HJ	A27611	1
7	WELDMENT BOOM EXT 5FT40	A27440	1
8	CYLINDER HYD 3 X 24 3000PSI MAX	A27165	1
9	PIN CLEVIS 1.000 X 2.750 EFF LENGTH SST	A22292	2
10	PIN CLEVIS 1.250 X 2.625 EFF LENGTH SST	A20174	1
11	PIN CLEVIS 1.250 X 5.500 EFF LENGTH SST	A7258	2
12	PIN HAIR COTTER .88/1.25 X .177 DIA SST	A9507	6
13	PIN CLEVIS 1.250 X 7.500 EFF LENGTH SST	A27491	1
14	PIN HEADLESS .375 X 6.000 EFF LENGTH SST	A27492	1
15	PIN LINCH .188 X 1.000 SST	A12416	2
16	PIN LINCH D .250 X 2.500 SST	A13549	1
17	SHEAVE ASSY .50 GR X 1.250 ID X 6.88 OD	A27490	2
18	PLUG FINISH RND .875 X 14-20GA BLK	A25168	1
19	RING RET EXT 1.250 SST	A3892	1
20	WASHER FLT SM OD 1.250 X 2.750 X .116 SST	A21430	1
21	O-RING 3.239 X 3.279 X .070 BUNA-N 70	A27358	1
22	PLATE BRG SLEW DRIVE INPUT	A27179	1
23	SEAL OIL 1.250ID X 1.500OD X .125	A5295	1
24	CAPSCR SOKBTNHD M12-1.75 X 20MM SST A4	A13275	2
25	KEY 8MM X 7MM X 30MM 4140 HT BES	A10098	1
26	SHAFT SLEW DRIVE INPUT	A27493	1
27	HANDLE MEDALLION ASSEMBLY	B4217	1
28	LABEL NAMEPLATE CRANES CE	A11529	1
29	LABEL SHEET SET 5FT40H	A30192	1
30	HARDWARE KIT CRANE WINCH .500-13NC SST	A25792	1
31	VALVE HAND LEVER SINGLE STATION 3 POS.	A22168	1
32	PUMP HAND W/ RETURN PORT	A22165	1
33	HYDRAULIC OIL MOBIL DTE 24 2.5 GAL	A13905	0.5
34	CAPSCR HEXHD .250-20NC X 2.500 SST 18-8	A4168	6
35	WASHER FLT SM OD .250 X .625 X .040 SST	A4270	12
36	NUT HEX NYLK .250-20NC SST 18-8	A2963	6
37	FITTING ELBOW 90 DEG -6 MJIC X -8 MORB SST	A36038	4
38	FITTING ELBOW 90 DEG -6 MJIC X -6 MORB SST	A36039	1
39	FITTING ELBOW 90 DEG 1/4 NPT X -6 MJIC SST	A36040	1
40	FITTING ADAPTER -6 MJIC X -8 MORB SST	A36041	2
41	FITTING ELBOW 90 DEG SWIVEL -6 JIC SST	A36042	2
42	HOSE ASSY PN -6 JICF X -6 JICF X 23 SST	A13961-23	1
43	HOSE ASSY PN -6 JICF X -6 JICF X 27 SST	A13961-27	2
44	HOSE ASSY PN -6 JICF X -6 JICF X 30 SST	A13961-30	1

* Specify finish when ordering.

Model 5FT100H

* Specify finish when ordering.

item	description	part number	qty.
1	WELDMENT BASE 5FT100	A31642	1
2	DRIVE SLEWING KE21 MANUAL	A36028	1
3	CAPSCR SOKHD M20-2.5 X 60MM M567 12.9	A36035	24
4	CAPSCR SOKHD M20-2.5 X 90MM M567 12.9	A36036	24
5	WASHER FLT M20 X 37MM X 3MM M567	A36037	48
6	WELDMENT MAST 5FT100 HJ	A31643	1
7	WELDMENT BOOM 5FT100 HJ	A31640	1
8	WELDMENT BOOM EXT 5FT100	A31639	1
9	CYLINDER HYD 5 X 24 3000PSI MAX	A31584	1
10	CLEVIS PIN	A9500	3
11	PIN CLEVIS 1.750 X 3.875 EFF LENGTH SST	A31614	1
12	PIN CLEVIS 1.750 X 7.000 EFF LENGTH SST	A31613	2
13	PIN LINCH D .250 X 1.750 SST	A12309	4
14	PIN HAIR COTTER .88/1.25 X .177 DIA SST	A9507	3
15	PIN CLEVIS 1.750 X 9.730 EFF LENGTH SST	A31607	1
16	PIN HEADLESS .500 X 7.250 EFF LENGTH SST	A31606	1
17	PIN LINCH .188 X 1.000 SST	A12416	2
18	PIN LINCH D .250 X 4.000 SST	A13555	1
19	SHEAVE ASSY .63 GR X 1.750 ID X 10.25 OD	A31610	2
20	PLUG FINISH RND .875 X 14-20GA BLK	A25168	1
21	RING RET EXT 1.250 SST	A3892	1
22	WASHER FLT SM OD 1.250 X 2.750 X .116 SST	A21430	1
23	O-RING 3.239 X 3.279 X .070 BUNA-N 70	A27358	1
24	PLATE BRG SLEW DRIVE INPUT	A27179	1
25	SEAL OIL 1.250ID X 1.500OD X .125	A5295	1
26	CAPSCR SOKBTNHD M12-1.75 X 20MM SST A4	A13275	2
27	KEY 8MM X 7MM X 30MM 4140 HT BES	A10098	1
28	SHAFT SLEW DRIVE INPUT 5FT100	A31632	1
29	HANDLE MEDALLION ASSEMBLY	B4217	1
30	VALVE HAND LEVER SINGLE STATION 3 POS.	A22168	1
31	PUMP HAND W/ RETURN PORT 121DA	A31674	1
32	HYDRAULIC OIL MOBIL DTE 24 2.5 GAL	A13905	1
33	CAPSCR HEXHD .250-20NC X 2.500 SST 18-8	A4168	6
34	WASHER FLT SM OD .250 X .625 X .040 SST	A4270	12
35	NUT HEX NYLK .250-20NC SST 18-8	A2963	6
36	FITTING ELBOW 90 DEG -6 MJIC X -8 MORB SST	A36038	2
37	FITTING ELBOW 90 DEG -6 MJIC X -6 MORB SST	A36039	1
38	FITTING ELBOW 90 DEG 1/4 NPT X -6 MJIC SST	A36040	1
39	FITTING ADAPTER -6 MJIC X -8 MORB SST	A36041	4
40	FITTING ELBOW 90 DEG SWIVEL -6 JIC SST	A36042	4
41	HOSE ASSY PN -6 JICF X -6 JICF X 27 SST	A13961-27	1
42	HOSE ASSY PN -6 JICF X -6 JICF X 30 SST	A13961-30	1
43	HOSE ASSY PN -6 JICF X -6 JICF X 32 SST	A13961-32	1
44	HOSE ASSY PN -6 JICF X -6 JICF X 35 SST	A13961-35	1
45	LABEL NAMEPLATE CRANES CE	A11529	1
46	LABEL SHEET SET 5FT100H	A36033	1

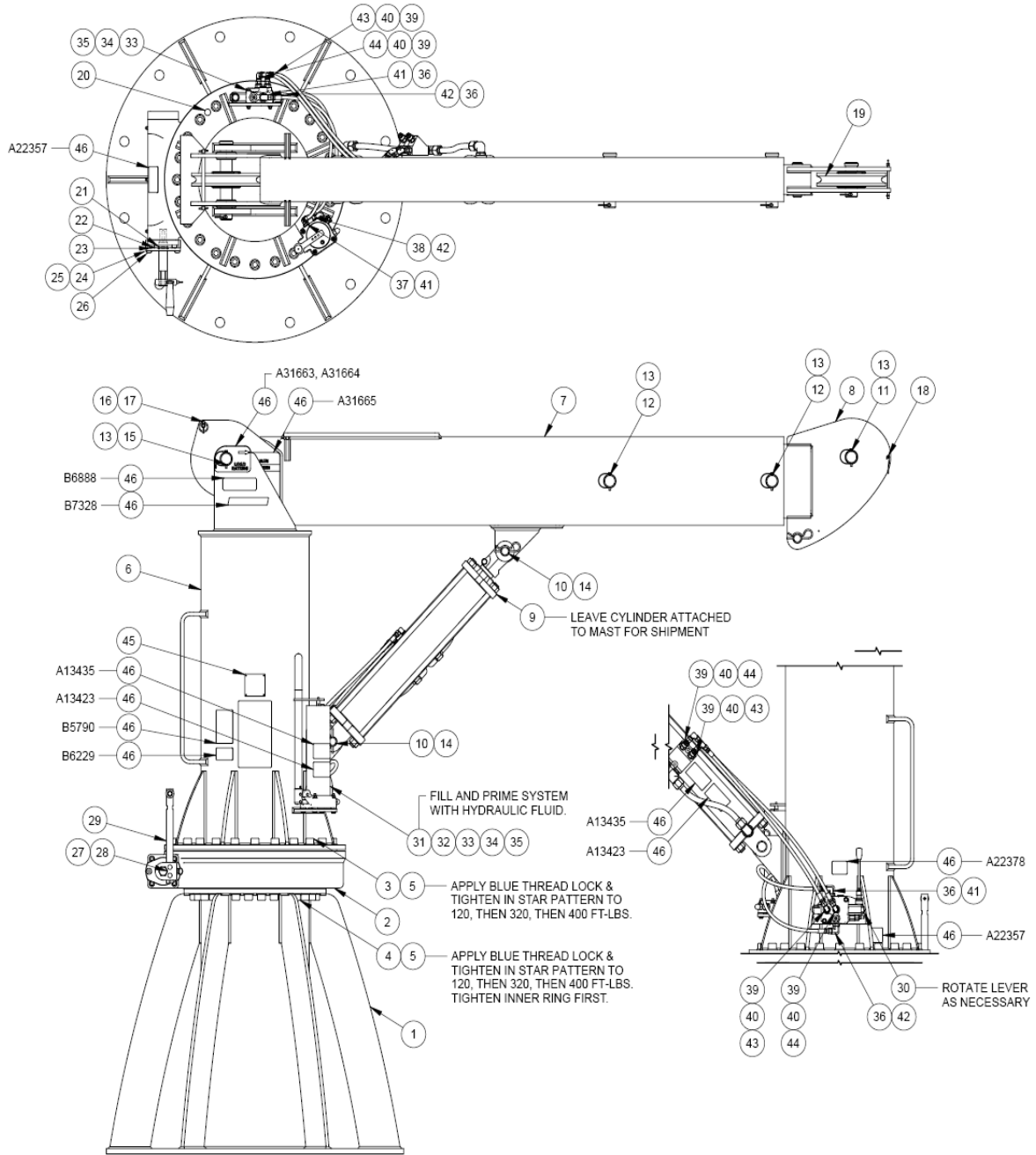

	-M1 *	-M1X *	-M2	-M2X
description	part number	part number	part number	part number
MANUAL WINCH	M452B-K	M452BEGRA-K	2W40V-BM-K	2W40V-BMX-K
(x4) CAPSCR HEXHD	A4192	A4192	A4192	A4192
(x4) HEX NUT	A4330	A4330	A4330	A4330
(x8) WASHER	A2882	A2882	A2882	A2882

	-E2	-E2T	-E3	-E4
description	part number	part number	part number	part number
POWER WINCH	3WG4B-K	3WG4MT-K	4HWF6M-KL	4HBN7M-KL
(x4) CAPSCR HEXHD	A4192	A4129	A2888	A2888
(x4) HEX NUT	A4330	A4330	A2887	A2887
(x8) WASHER	A2882	A2882	A9867	A9867

	-E2X	-E2TX	-E3X	-E4X
description	part number	part number	part number	part number
POWER WINCH	3wg4b-KX	3WG4MTX-K	4HWF6MX-KL	4HBN7MX-KL
(x4) CAPSCR HEXHD	A4192	A4192	A2888	A2888
(x4) HEX NUT	A4330	A4330	A2887	A2887
(x8) WASHER	A2882	A2882	A9867	A9867

* M1 manual winch not available with 5FT40H series.

5FT40 Series Lift Below Floor²

Lift Below ¹ Floor				Wire Rope Diameter		Wire Rope ³ Length		Winch Configurations Maximum Winch Rating (lbs)				
Minimum (C4)		Maximum (C1)						M1	M2	E2	E2T	E3
(ft)	(m)	(ft)	(m)	(in)	(mm)	(ft)	(m)	(lb)	(lb)	(lb)	(lb)	(lb)
-4	-1.2	2	0.6	3/8	10	28	8.5	4100	4100	4100	3700	4100
4	1.2	10	3.0	3/8	10	36	10.9	4100	4100	3600	3300	4100
13	3.9	19	5.7	3/8	10	45	13.7	3700	4100	3600	3300	4100
28	8.5	34	10.3	3/8	10	60	18.2	3700	3700	3200	2900	4100
43	13.1	49	14.9	3/8	10	75	22.8	3400	3400	3200	2900	4100
58	17.6	64	19.5	3/8	10	90	27.4	-	3400	2900	2700	4100
88	26.8	94	28.6	3/8	10	120	36.5	-	-	2700	2400	4100
118	35.9	124	37.7	3/8	10	150	45.7	--	-	-	2200	4100
-4	-1.2	2	0.6	7/16	11	28	8.5	3900	3900	3300	3000	5500
4	1.2	10	3.0	7/16	11	36	10.9	3400	3900	3300	3000	5500
13	3.9	19	5.7	7/16	11	45	13.7	3400	3400	3300	3000	5500
28	8.5	34	10.3	7/16	11	60	18.2	3000	3000	2900	2600	5500
43	13.1	49	14.9	7/16	11	75	22.8	-	3000	2600	2300	5000
58	17.6	64	19.5	7/16	11	90	27.4	-	-	2600	2300	5000
88	26.8	94	28.6	7/16	11	120	36.5	-	-	-	2100	4600
118	35.9	124	37.7	7/16	11	150	45.7	-	-	-	1900	4200
-4	-1.2	2	0.6	1/2	13	28	8.5	3700	3700	3200	3000	5500
4	1.2	10	3.0	1/2	13	36	10.9	3200	3700	3200	3000	5500
13	3.9	19	5.7	1/2	13	45	13.7	3200	3200	2800	2500	5500
28	8.5	34	10.3	1/2	13	60	18.2	-	-	2800	2500	5500
43	13.1	49	14.9	1/2	13	75	22.8	-	-	-	2200	5000
58	17.6	64	19.5	1/2	13	90	27.4	-	-	-	2000	5000
88	26.8	94	28.6	1/2	13	120	36.5	-	-	-	1800	4500
118	35.9	124	37.7	1/2	13	150	45.7	-	-	-	-	-

	Boom Position	Maximum Load Rating		Hook Reach		Hook Height	
		lbs	(kg)	inch	(mm)	inch	(mm)
BLUE RANGE	A-1	4800	(2180)	77	(1955)	68	(1727)
	A-2	4100	(1860)	92	(2337)	68	(1727)
	A-3	3500	(1590)	107	(2717)	68	(1727)
	A-4	3000	(1360)	122	(3098)	68	(1727)
GREEN RANGE	B-1	5500	(2500)	69	(1753)	102	(2590)
	B-2	4600	(2090)	82	(2083)	108	(2743)
	B-3	4000	(1810)	96	(2438)	115	(2921)
	B-4	3300	(1500)	109	(2768)	121	(3073)
	C-1	5500	(2500)	55	(1397)	122	(3098)
	C-2	4600	(2090)	66	(1677)	132	(3352)
	C-3	4000	(1810)	77	(1955)	143	(3632)
	C-4	3300	(1500)	87	(2209)	153	(3886)

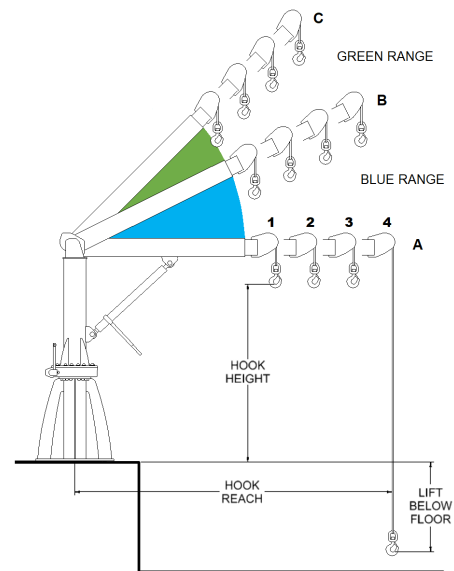

IMPORTANT:
It is the owner or operator's responsibility to determine the suitability of the equipment to its intended use. Study all applicable codes, manuals and regulations. Be sure to read the Owner's Manual supplied with the equipment before operating it.

¹ Lift below floor level varies depending on boom position. For longer lifts, including use with two-part line kits, please contact factory.

² Performance Characteristics are for standard products referred to in this manual. Non-standard products may vary from the original design. Contact Thern, Inc. for this information.

³ Wire rope assemblies include a swivel hook with an unfinished end.

5FT100 Series Lift Below Floor²

Lift Below ¹ Floor				Wire Rope Diameter		Wire Rope ³ Length		Winch Configurations		
Minimum (C3)		Maximum (C1)						M1	E3	E4
(ft)	(m)	(ft)	(m)	(in)	(mm)	(ft)	(m)	(lbs)	(lbs)	(lbs)
-3	0	2	0	7/16	11	45	13	11,000 *	11,000 *	11,000 *
5	1	10	3	7/16	11	60	18	11,000 *	11,000 *	11,000 *
12	3	17	5	7/16	11	75	22	11,000 *	9800 *	11,000 *
20	6	25	7	7/16	11	90	27	11,000 *	9800 *	11,000 *
35	10	40	12	7/16	11	120	36	11,000 *	9000 *	11,000 *
50	15	55	16	7/16	11	150	45	11,000 *	8200 *	11,000 *
75	22	80	24	7/16	11	200	60	11,000 *	-	11,000 *
100	30	105	32	7/16	11	250	76	-	-	-
-2	0	4	1	1/2	13	36	10	7600	5500	7200
7	2	13	3	1/2	13	45	13	7600	5300	7200
22	6	28	8	1/2	13	60	18	7600	5300	7200
37	11	43	13	1/2	13	75	22	7600	4700	7200
52	15	58	17	1/2	13	90	27	7600	4700	6800
82	24	88	26	1/2	13	120	36	7600	4300	6800
112	34	118	35	1/2	13	150	45	7000	-	6800
162	49	168	51	1/2	13	120	60	-	-	-
-2	0	4	1	9/16	14	36	10	-	5200	7200
7	2	13	3	9/16	14	45	13	-	5200	7200
22	6	28	8	9/16	14	60	18	-	5200	7200
37	11	43	13	9/16	14	75	22	-	4600	7200
52	15	58	17	9/16	14	90	27	-	4100	6600
82	24	88	26	9/16	14	120	36	-	4100	6600
112	34	118	35	9/16	14	150	45	-	-	-
-2	0	4	1	5/8	16	36	10	-	-	7200
7	2	13	3	5/8	16	45	13	-	-	7200
22	6	28	8	5/8	16	60	18	-	-	7200
37	11	43	13	5/8	16	75	22	-	-	6400
52	15	58	17	5/8	16	90	27	-	-	6400
82	24	88	26	5/8	16	120	36	-	-	5800
112	34	118	35	5/8	16	150	45	-	-	-

5FT100 Series Load Rating, Hook Height and Reach							
	Boom Position	Maximum Load Rating		Hook Reach		Hook Height	
		lbs	(kg)	inch	(mm)	inch	(mm)
BLUE RANGE	A-1	11000	(5000)	86	(2184)	56	(1422)
	A-2	9000	(4080)	110	(2794)	56	(1422)
	A-3	7500	(3400)	134	(3403)	56	(1422)
GREEN RANGE	B-1	11000	(5000)	80	(2032)	92	(2336)
	B-2	11000	(5000)	101	(2565)	102	(2590)
	B-3	10000	(4535)	123	(3214)	112	(2844)
	C-1	11000	(5000)	70	(1778)	112	(2844)
	C-2	11000	(5000)	88	(2235)	127	(3225)
	C-3	10000	(4535)	107	(2718)	142	(3606)

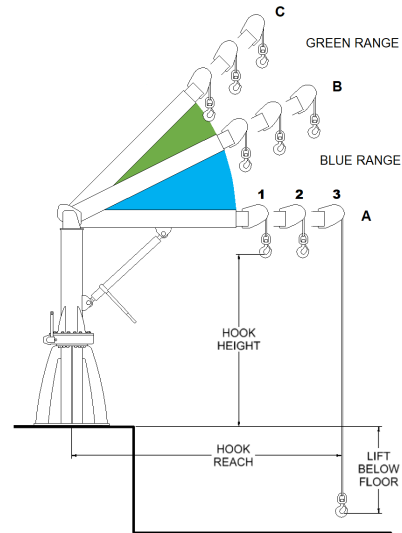

IMPORTANT:
It is the owner or operator's responsibility to determine the suitability of the equipment to its intended use. Study all applicable codes, manuals and regulations. Be sure to read the Owner's Manual supplied with the equipment before operating it.

¹ Lift below floor level varies depending on boom position. For longer lifts, including use with two-part line kits, please contact factory.

² Performance Characteristics are for standard products referred to in this manual. Non-standard products may vary from the original design. Contact Thern, Inc. for this information.

³ Wire rope assemblies include a swivel hook with an unfinished end.

*Requires 5FT100TPL two-part line kit.



Thern, Incorporated
5712 Industrial Park Road
Winona, MN 55987

Toll Free: 1-800-843-7648
Phone: 1-507-454-2996

Email: info@thern.com
www.thern.com

Thern Europe
Siriusdreef 17-27,
2132 WT Hoofddorp
The Netherlands

Phone: +31-546-898380
Email: europe@thern.com