

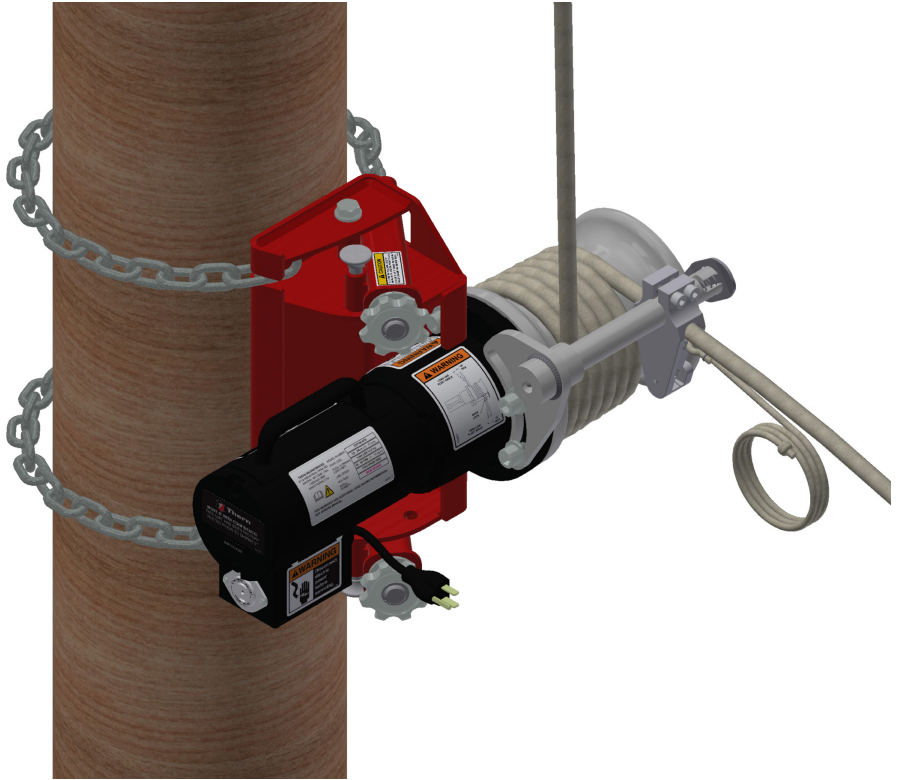

Read these instructions thoroughly before operating the equipment. Keep it with the equipment at all times. Replacements are available from Thern, Inc., PO Box 347, Winona, MN 55987, 507-454-2996. www.thern.com

ORIGINAL TEXT



Supplemental Instructions

For 3CP1M-PM Capstan Pole Mount

These instructions are to serve as guidelines for hazard-free installation, operation, and maintenance. They should not be understood to prepare you for every possible situation.

Suggestions for Safe Operation

Keep these instructions readable and with the equipment at all times. Contact Thern, Inc. for replacements.

Keep all unnecessary personnel away while in operation.

Do not exceed the load rating of the capstan or any other component in the system. To do so could result in failure of the equipment.

Do not use damaged or malfunctioning equipment. To do so could result in failure of the equipment.

Do not modify the equipment in any way. To do so could cause equipment failure.

Do not use the capstan components for any use other than for their original intended function.

Attach the winch only to structurally sound locations capable of supporting the equipment and all reaction loads.



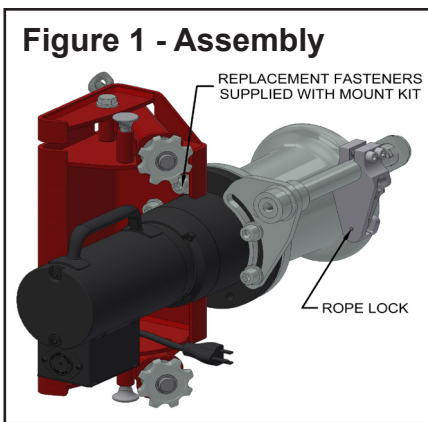

1.1 Assembling the Capstan

- 1.1.1 STUDY PARTS DRAWING to understand how the pole mount bracket is assembled. See page 3.
- 1.1.2 MOUNT THE CAPSTAN to the pole mount bracket using the four supplied fasteners. Use blue thread lock compound and tighten to 50 ft-lbs. (68 Nm). See **Figure 1**.
- 1.1.3 ROTATE THE ROPE LOCK as needed to allow proper operation and rope take-off position. You may need to remove and reconfigure the rope lock mounting bar for correct orientation. See **Figure 1**.

1.2 Installing the Capstan

⚠WARNING

Attach the winch only to structurally sound locations capable of supporting the equipment and all reaction loads. **WORKING LOAD LIMIT: 1000 lbs. (450 kg)**

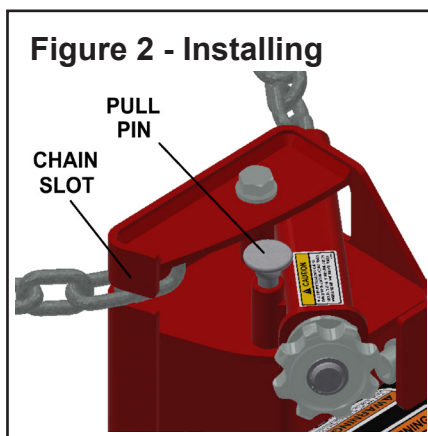

- 1.2.1 MOUNTING ON A POLE
 - a. PULL PINS AT CHAIN TUBES to allow tubes to pivot. This allows the bracket to sit properly against round or multi-sided poles.
 - b. LOOSEN THE CHAIN TENSIONERS completely by rotating the hand knobs counterclockwise until they reach the end.
 - c. PASS THE CHAINS around the pole and attach chain link to slot in bracket. See **Figure 2**.
 - d. TIGHTEN THE CHAINS by rotating the tensioner hand knobs clockwise. Do this for both chains. It may be necessary to retighten the chains after initial capstan operation under load.
- 1.2.2 MOUNTING ON A TOWER OR BEAM
 - a. PIVOT CHAIN TUBES until pins lock into place. This forms a 90-degree shoulder between the chain tensioner and the bracket for mounting to a square cornered member.
 - b. STEPS b – d are the same as above.

1.3 Inspecting the Equipment

Do not use damaged or malfunctioning equipment. Place an “OUT OF ORDER” sign on the equipment. Do not use the equipment until the sign is removed by a qualified person who has completely corrected the problem.

- 1.3.1 INSPECT THE EQUIPMENT before each use to detect signs of damage or poor operation before they become hazardous.
 - Check all equipment for cracks, dents, bending, rust, wear, corrosion, and other damage.
 - Make sure all fasteners are tight and secure.

Model 3CP1M-PM

item	description	part number	qty.
1	WELDMNT FRAME	A35893	1
2	CAPSCR SOKHD M12-1.75 X 30MM ZNPL 12.9	A10641	4
3	WASHER FLT M12 X 24MM X 2.5MM ZNPL	A9879	8
4	CAPSCR HEXHD M12-1.75 X 75MM ZNPL 8.8	A34659	2
5	NUT HX NYLK M12-1.75 ZNPL CL8	A9878	2
6	ADJUSTER LOCK PULL	A35907	2
7	ADJUSTER LOCK PIN	A35908	2
8	SPRING COMP .480OD X .036WD X 1.00 SST	A11046	2
9	WELDMNT ADJUSTER	A35897	2
10	WASHER FLT SAE .875 X 1.750 X .134 ZNPL	A3601	2
11	ADJUSTER ASSEMBLY	A35902	2
12	KNOB ADJUSTER	A35906	2
13	RING RET EXT INVERT .750 SS	A13828	2
14	LABEL THERN 1.00 X 3.00	A6889	1
15	LABEL DRUM ROTATION CAPSTAN	A23843	1
16	LABEL WLL 1000 LBS	A28953	1
17	LABEL CAUTION PULL THIS PIN	A28976	2

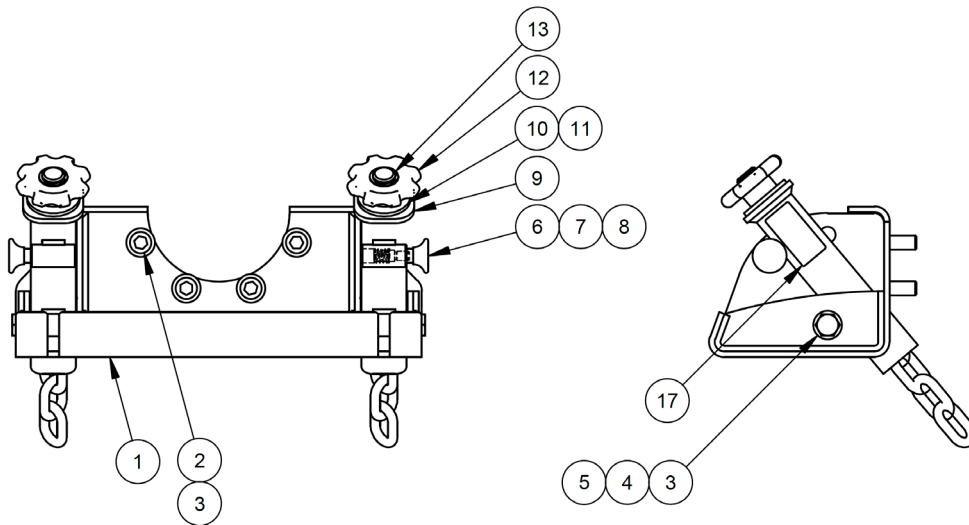



Thern, Incorporated
5712 Industrial Park Road
Winona, MN 55987
PH: 507-454-2996
FAX: 507-454-5282
EMAIL: info@thern.com
www.thern.com

Thern Europe
Siriusdreef 17-27, 2132 WT
Hoofddorp
The Netherlands
PH: +31-546-898-380
EMAIL: europe@thern.com