



Read this Owner's Manual thoroughly before operating the equipment. Keep it with the equipment at all times. Replacements are available from Thern, Inc., PO Box 347, Winona, MN 55987, 507-454-2996. [www.thern.com](http://www.thern.com)



**IMPORTANT:** Please record product information on page 2. This information is required when calling the factory for service.



# Owner's Manual

For  
4WP2D Series  
Worm Gear Power Winches

## Two-Year Limited Warranty

**Please record the following:**

Date Purchased: \_\_\_\_\_

Model No.: \_\_\_\_\_

Serial No.: \_\_\_\_\_

**This information is required when calling the factory for service.**

Thern, Inc. warrants its products against defects in material or workmanship for two years from the date of purchase by the original using buyer, or if this date cannot be established, the date the product was sold by Thern, Inc. to the dealer. To make a claim under this warranty, contact the factory for an RGA number. The product must be returned, prepaid, directly to Thern, Inc., 5712 Industrial Park Road, Winona, Minnesota 55987. The following information must accompany the product: the RGA number, the date of purchase, the description of the claimed defect, and a complete explanation of the circumstances involved. If the product is found to be defective, it will be repaired or replaced free of charge, and Thern, Inc. will reimburse the shipping cost within the contiguous USA.

This warranty does not cover any damage due to accident, misuse, abuse, or negligence. Any alteration, repair or modification of the product outside the Thern, Inc. factory shall void this warranty. This warranty does not cover any costs for removal of our product, downtime, or any other incidental or consequential costs or damages resulting from the claimed defects. This warranty does not cover brake discs, as these are wear components and their life is subject to use conditions which vary between applications.

FACTORY AUTHORIZED REPAIR OR REPLACEMENT AS PROVIDED UNDER THIS WARRANTY IS THE EXCLUSIVE REMEDY TO THE CONSUMER. THERN, INC. SHALL NOT BE LIABLE FOR ANY INCIDENTAL OR CONSEQUENTIAL DAMAGES FOR BREACH OF ANY EXPRESS OR IMPLIED WARRANTY ON THIS PRODUCT. EXCEPT TO THE EXTENT PROHIBITED BY APPLICABLE LAW, ANY IMPLIED WARRANTY OF MERCHANTABILITY OR FITNESS FOR A PARTICULAR PURPOSE ON THIS PRODUCT IS LIMITED IN DURATION TO THE DURATION OF THIS WARRANTY.

Some states do not allow the exclusion or limitation of incidental or consequential damages, or allow limitations on how long an implied warranty lasts, so the above limitation or exclusion may not apply to you. This warranty gives you specific legal rights, and you may also have other rights which vary from state to state.

**Note: Thern, Inc. reserves the right to change the design or discontinue the production of any product without prior notice.**

## About This Manual

The Occupational Safety and Health Act of 1970 states that it is the employer's responsibility to provide a workplace free of hazard. To this end, all equipment should be installed, operated, and maintained in compliance with applicable trade, industrial, federal, state, and local regulations. It is the equipment owner's responsibility to obtain copies of these regulations and to determine the suitability of the equipment to its intended use.

This Owner's Manual, and warning labels attached to the equipment, are to serve as guidelines for hazard-free installation, operation, and maintenance. They should not be understood to prepare you for every possible situation.

The information contained in this manual is applicable only to the Thern 4WP2D Series Worm Gear Power Winches. Do not use this manual as a source of information for any other equipment.

**The following symbols are used for emphasis throughout this manual:**

**▲WARNING**

Failure to follow 'WARNING!' instructions may result in equipment damage, property damage, and/or serious personal injury.

**▲CAUTION**

Failure to follow 'CAUTION!' instructions may result in equipment damage, property damage, and/or minor personal injury.

**Important!**

Failure to follow 'important!' instructions may result in poor performance of the equipment.

## Suggestions for Safe Operation

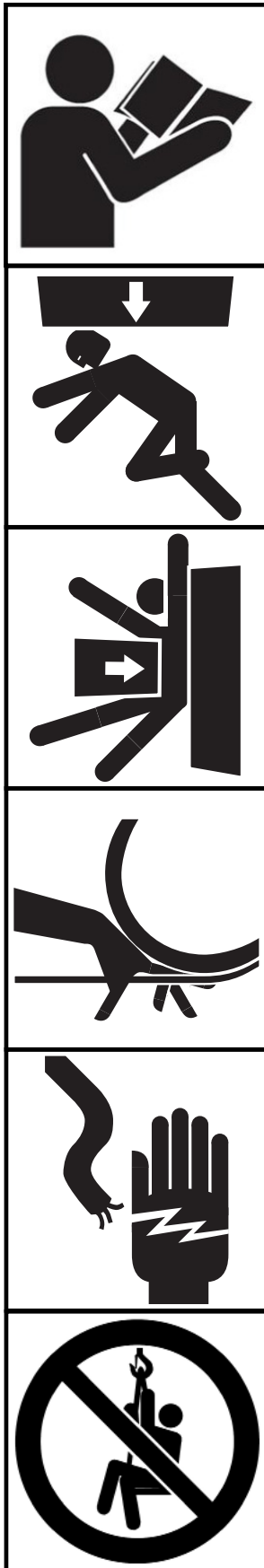

### **⚠ WARNING**

#### **DO the following:**

Read and comply with the guidelines set forth in this Owner's Manual. Keep this manual, and all labels attached to the winch, readable and with the equipment at all times. Contact Thern, Inc. for replacements.

Check lubrication before use.

Install the wire rope securely to the winch drum.

Keep at least 4 wraps of wire rope wound on the drum at all times, to serve as anchor wraps. With less than 4 wraps on the drum the wire rope could come loose, causing the load to escape.

Keep hands away from the drum, wire rope, and other moving parts of the equipment.

Keep all unnecessary personnel away from winch while in operation. Keep out of the path of the load and out of the path of a broken wire rope that might snap back and cause injury.

Disconnect power before servicing the equipment.

#### **DO NOT do the following:**

Do not lift people, or things over people. Do not walk or work under a load or in the line of force of any load.

Do not use clutch equipped models to lift loads, or drag loads on an incline. Accidental release of the clutch could result in loss of the load.

Do not exceed the load rating of the winch or any other component in the system. To do so could result in failure of the equipment.

Do not use more than one winch to move a load unless each winch was designed for use in a multiple winch system.

Do not use damaged or malfunctioning equipment. To do so could result in failure of the equipment.

Do not modify the equipment in any way. To do so could cause equipment failure.

Do not wrap the wire rope around the load. This damages the wire rope and could cause the load to escape. Use approved rigging connectors to secure the wire rope to the load.

Do not lift loads or pull loads on an incline unless the winch is equipped with a load brake.

Do not divert your attention from the operation. Stay alert to the possibility of accidents, and try to prevent them from happening.

Do not jerk or swing the load. Avoid shock loads by starting and stopping the load smoothly. Shock loads overload the equipment and may cause damage.

Do not leave a suspended load unattended unless specific precautions have been taken to secure the load and keep people away from the winch and out from under the load.

Do not adjust the brake with the load suspended.

Do not exceed the 5 minute duty cycle rating of the winch. To do so could result in equipment damage or failure.

## 1.1 Installing the Winch

### **⚠WARNING**

#### **Important!**

- Inspect the winch immediately following installation according to the Instructions for Periodic Inspection. This will give you a record of the condition of the winch with which to compare future inspections.
- A qualified professional should inspect or design the foundation to insure that it will provide adequate support.
- Locate the winch so it will be visible during the entire operation.
- Do not weld the winch frame to the foundation or support structure. Welding the frame may void warranty, contact Thern, Inc. Use fasteners as instructed.

**Do not install the winch in an area defined as hazardous by the National Electric Code, unless installation in such an area has been thoroughly approved.**

**Do not install the winch near corrosive chemicals, flammable materials, explosives, or other elements that may damage the winch or injure the operator. Adequately protect the winch and the operator from such elements.**

**Position the winch so the operator can stand clear of the load, and out of the path of a broken wire rope that could snap back and cause injury.**

**Attach the winch to a rigid and level foundation that will support the winch and its load under all load conditions, including shock loading.**

- 1.1.1 CONSULT APPLICABLE CODES AND REGULATIONS for specific rules on installing the equipment.
- 1.1.2 LOCATE THE WINCH in an area clear of traffic and obstacles. Make sure the winch is accessible for maintenance and operation.
- 1.1.3 LOCATE THE WINCH in an area with adequate temperatures. The winch is rated for operation in ambient temperatures ranging from 0° to 100° F.
- 1.1.4 MAINTAIN A FLEET ANGLE between 1/2 and 1-1/2 degrees. The proper fleet angle minimizes wire rope damage by helping the wire rope wind uniformly onto the drum. See Figure 2.
- 1.1.5 POSITION THE WINCH to allow access for proper lubrication.
- 1.1.6 FASTEN THE WINCH securely to the foundation.
  - a FOR STANDARD PRODUCTS referred to in this manual, use 3/8 - inch coarse thread fasteners, grade 5 or better, torque dry to 30 ft lb without lubrication. Make sure the winch is secured to a solid foundation able to support the winch and the load under all conditions with design factors based on accepted engineering practices.
  - b NON-STANDARD PRODUCTS that vary from the original design may have different fastening requirements. Contact a structural engineer or Thern, Inc. for this information.

**TO COMPLY WITH LOCAL CODES, CONTACT A QUALIFIED PROFESSIONAL TO OBTAIN PROPER STRUCTURE OR FOUNDATION SPECIFICATIONS FOR THE MOUNTING OF THERN PRODUCTS.**

## 1.2 Installing the Breather Plug

**Important!**

- Save the oil plug for use when the winch is removed for storage or transport.

**CAUTION**

Install the breather plug to vent heat and pressure from the gearbox. Failure to do so could result in pressure buildup which can cause the gearbox to leak or damage the equipment.

For shipment, the gearbox is sealed with an oil plug, and the breather plug is attached to the gearbox or shipped in a separate envelope.

- 1.2.1 REMOVE THE OIL PLUG and install the breather plug in the proper location. Make sure the breather plug is above the level of the oil. See Figure 1.
- 1.2.2 CHECK THE OIL LEVEL in the gearbox to make sure no oil was lost during shipment. See Section 3.3 Lubricating the Winch.

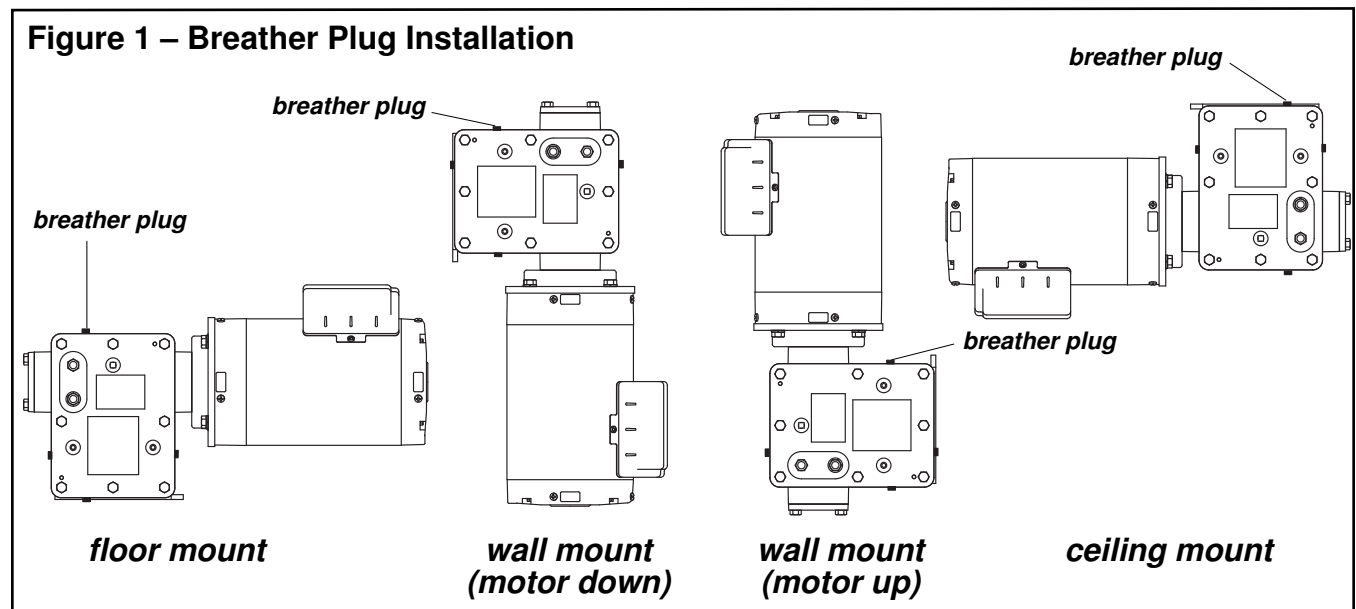

**Important!**

- Use a sheave or roller guide to direct the wire rope to the drum whenever possible.
- Install sheaves, tracks and other equipment so they will remain fixed under all load conditions. Follow the recommendations of the equipment manufacturer.
- Use sheaves of proper diameter to minimize wear on the wire rope. Follow the recommendations of the sheave manufacturer.

**Figure 2 – Maintaining the Fleet Angle**

When wire rope travels over a sheave or through a roller guide – maintain fleet angle by locating the sheave or guide an appropriate distance from the drum, shown as distance “A”.

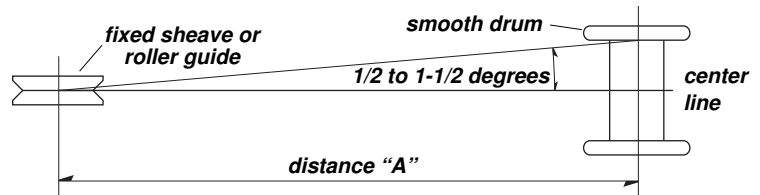

When wire rope travels directly to the load – maintain fleet angle by controlling side-to-side movement of the load with tracks or guide rails. Allowing the load to move too far to one side causes stress on the drum flange which may cause damage.

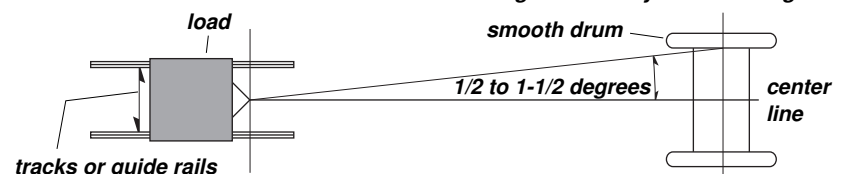

### 1.3 Removing Motor Drain Plugs

Some electric motors are equipped with screw plugs which are designed to be removed to provide drain holes.

1.3.1 LOCATE THE LOWEST POINT ON THE ELECTRIC MOTOR.

1.3.2 REMOVE THE SCREW PLUG located at this lowest point. See Figure 3.

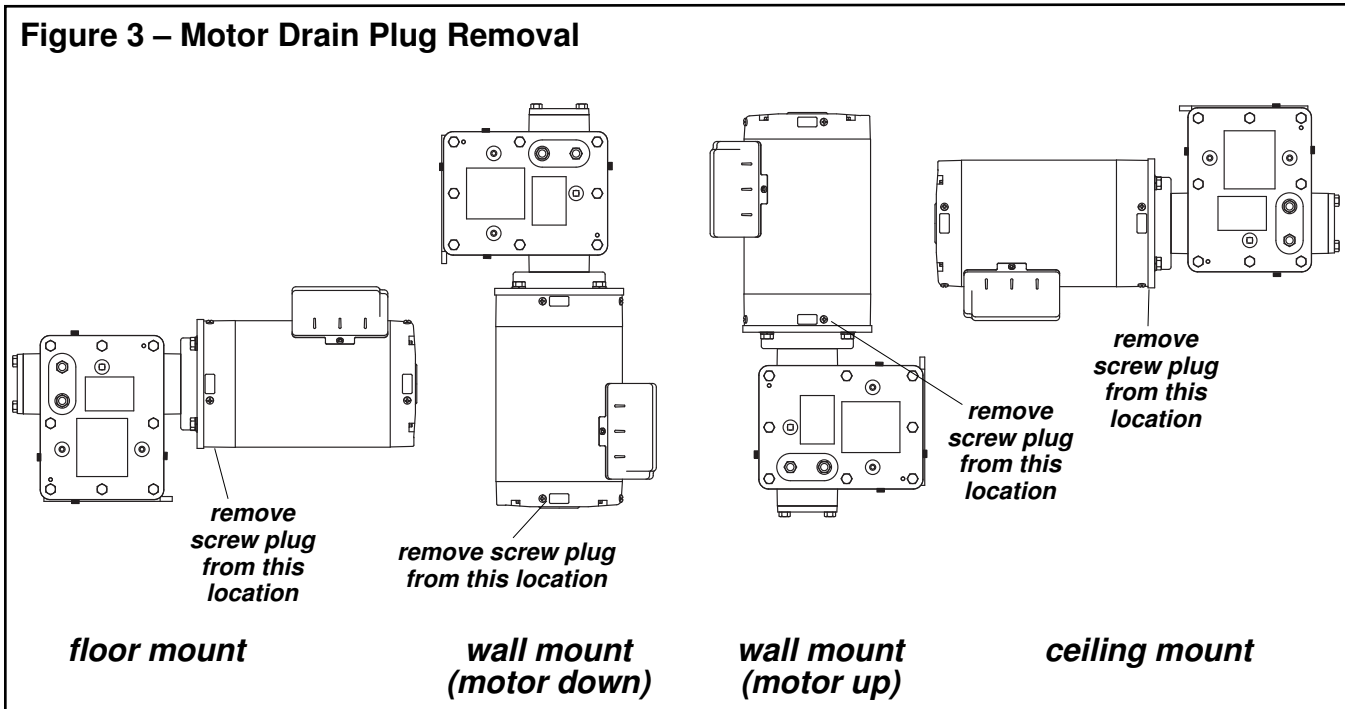

---

## 1.4 Connecting Power

**Important!**

- Use components rated for the power supply you will be using.
- Always disconnect power when the winch is not in use.

**⚠WARNING**

**Install proper branch circuits, disconnect devices, protection, and grounding as required by article 430 of the National Electric Code.**

**All electrical work must be performed by a licensed electrician. Failure to do so could result in electric shock or poor winch operation.**

**All control devices must be momentary contact type. Install all control devices so the winch motor will stop when the operator releases the device.**

**Locate control devices so the operator will be able to view the load through the entire operation.**

**Locate control devices so the operator will be clear of the load, the wire rope, and the path of a broken wire rope that could snap back and cause injury.**

It is the responsibility of the owner to provide equipment for controlling the winch. Controls are available from Thern. The following guidelines are supplied as a reference for the installer.

- 1.4.1 CONSULT APPLICABLE CODES AND REGULATIONS for specific instructions regarding power supply installation and hookup.
- 1.4.2 FOR ELECTRIC WINCHES: install a fuse or circuit breaker, and a disconnect device in the power supply circuit, as required by the National Electric Code. The disconnect device should be a switch you can lock in the OFF position to prevent unauthorized use of the winch.
- 1.4.3 CONNECT THE POWER CORD to a grounded outlet.
- 1.4.4 FOR PNEUMATIC WINCHES: install a regulator, filter, lubricator and drier in the air supply line. Failure to operate with clean, dry, lubricated air will void warranty.
- 1.4.5 FOR HYDRAULIC WINCHES: install a filter in the hydraulic supply line. **Use Mobil DTE hydraulic fluid, or equal, with a viscosity range of 100 – 200 SUS.**
- 1.4.6 INSTALL A CONTROL DEVICE in the power supply line and connect power to the motor. Make sure the control device is a momentary contact type so the motor will stop when the operator releases the control.
- 1.4.7 CONNECT OTHER EQUIPMENT to the power supply as necessary.
- 1.4.8 CHECK POWER SUPPLY at the motor and make sure it agrees with the motor rating. Do not operate the winch until proper power is supplied to the motor.
- 1.4.9 TEST CONNECTIONS by operating the winch. The rotation of the drum must agree with the labels on the control device, and the motor must stop when the control is released.

**CONTACT THE FACTORY OR A QUALIFIED PROFESSIONAL FOR HELP.**



## 1.5 Installing the Wire Rope

### Important!

- Use wire rope and other rigging equipment rated for the size of the largest load you will be moving.
- Do not drag the wire rope through dirt or debris that could cause damage, or poor operation.
- Always wear protective clothing when handling wire rope.

### ⚠WARNING

**Install the wire rope securely to the winch drum. A poorly secured wire rope could come loose from its anchor and allow the load to escape.**

**Do not use 3/16 inch or smaller wire rope on standard drums. To do so could cause damage to the wire rope and allow the load to escape.**

**Install the wire rope so it is wound correctly as shown or the winch and brake will not work properly, and could allow the load to escape, see Figure 4.**

**Figure 4 – Installing the Wire Rope**

*install the wire rope so it is underwound on the drum as shown*

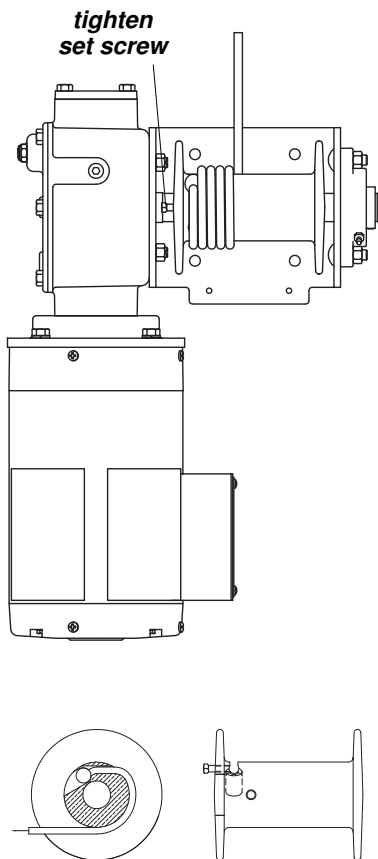

*typical installation shown underwound*

**Wire rope assemblies with anchor fittings can be purchased from Thern, Inc.**

- 1.5.1 PURCHASE THE PROPER WIRE ROPE for your application. Keep the following in mind when selecting a wire rope. Contact a reputable wire rope supplier for help.
  - a BREAKING STRENGTH of new wire rope should be at least 3 times greater than the largest load placed on the winch. If loads are lifted or pulled on an incline, the breaking strength must be at least 5 times greater than the largest load. These are minimum values and will vary with the type of load and how you are moving it.
  - b WIRE ROPE LAY must agree with the winding direction of the drum to help insure proper winding.
  - c WE RECOMMEND 7x19 galvanized aircraft cable for diameters up to 5/16 inch. Do not use 3/16 inch or smaller wire rope on standard drums.
- 1.5.2 ANCHOR THE WIRE ROPE to the drum using either the set screw or quick disconnect anchor.
  - a SET SCREW ANCHOR. See Figure 4.
    - PASS THE WIRE ROPE under the drum from the front and position it in the slot in the drum. Make sure at least 1/2 inch of wire rope extends past the set screw, and the end of the wire rope does not protrude out where it will interfere with wire rope winding onto the drum.
    - TIGHTEN THE SET SCREW to hold the wire rope in place. Hold the wire rope down while tightening so the wire rope does not push up out of the slot.
  - b QUICK DISCONNECT ANCHOR. See Figure 4.
    - PASS THE WIRE ROPE under the drum from the front and position the anchor fitting in the groove in the drum.
    - PULL THE WIRE ROPE to firmly lodge the anchor fitting in place.
- 1.5.3 WIND FOUR FULL WRAPS of wire rope onto the drum by operating the winch while holding the wire rope taught. **These wraps serve as anchor wraps and must remain on the drum at all times.** See Figure 4.

**CONTACT A REPUTABLE WIRE ROPE SUPPLIER FOR HELP.**



## 2.1 General Theory of Operation

### Important!

- Limit nonuniform winding by keeping tension on the wire rope and by maintaining the proper fleet angle.
- To help insure rated performance, make sure power supply at the motor is equal to the motor's power rating.
- It is your responsibility to detect and account for different factors affecting the condition and performance of the equipment.

- 2.1.1 THE PULL REQUIRED to move the load must not exceed the load rating of the winch. Consider the total force required to move the load, not the weight of the load.
- 2.1.2 THE AMOUNT OF TIME required to move the load must not exceed the 5 minute duty cycle rating of the winch.
- 2.1.3 THIS EQUIPMENT CAN develop forces that will exceed the load rating. It is the responsibility of the equipment user to limit the size of the load. Inspect the equipment regularly for damage according to the instructions contained in this manual and in component manufacturer's information.
- 2.1.4 USE A LOAD BRAKE on all winches used to lift loads or pull loads on an incline. Although a new winch may appear to hold the load in place, this characteristic will diminish with use. **Do not depend on gearing to hold the load in place.**
- 2.1.5 PERFORMANCE RATINGS of the equipment are affected by the amount of wire rope wound on the drum, the way in which it is wound, and the way the winch is used.
- a DRUM CAPACITY depends on how tightly and evenly the wire rope is wound on the drum. "Actual drum capacities are usually 25-30% less than values shown in performance Tables, due to loose winding and over lapping."
  - b LINE SPEED increases with each additional layer of wire rope wound onto the drum. Line speed will also vary with load weight and power supply for pneumatic and hydraulic models. Load weight does not affect line speed for electric models.
  - c LOAD RATING represents the maximum pull that can be placed on new equipment. Load ratings are assigned values for specific amounts of load travel or wire rope accumulation. The load rating decreases as layers of wire rope accumulate on the drum.
- 2.1.6 DUTY RATINGS refer to the type of use the equipment is subject to. Consider the following when determining duty rating. The winch has a 5 minute duty cycle rating.
- a ENVIRONMENT: harsh environments include hot, cold, dirty, wet, corrosive, or explosive surroundings. **Protect the equipment from harsh environments when possible.**
  - b MAINTENANCE: poor maintenance, meaning poor cleaning, lubrication, or inspection, leads to poor operation and possible damage of the equipment. **Minimize poor maintenance by carefully following the instructions contained in this manual.**
  - c LOADING: severe loading includes shock loading and moving loads that exceed the load rating of the equipment. **Avoid shock loads, and do not exceed the load rating of the equipment.**
  - d FREQUENCY OF OPERATION: frequent or lengthy operations increase wear and shorten the life span of gears, bearings, and other components. **Increase maintenance of the equipment if used in frequent operations. Length of operation should not exceed the 5 minute duty cycle rating.**

CONTACT THE FACTORY FOR MORE INFORMATION.

## 2.2 Breaking-In the Winch

- 2.2.1 BREAK-IN OCCURS during the first 30 to 60 minutes of operation. During break-in, mating surfaces become polished, and clearances increase. This is desired for efficient operation of bearings and gears.
- 2.2.2 INSPECT THE WINCH following break-in according to the Instructions for Periodic Inspection. See Section 3.4 Inspecting the Equipment.

## 2.3 Preparing for Operation

### Important!

- When determining whether the load will exceed the load rating, consider the total force required to move the load.

- 2.3.1 CONSIDER THE OPERATION. Do not begin until you are sure you can perform the entire operation without hazard.
- 2.3.2 INSPECT ALL COMPONENTS of the system.
- INSPECT THE WINCH and other equipment according to the Instructions for Frequent Inspection.
  - OPERATORS must be in good health, alert, thoroughly trained in operating the equipment, and properly clothed (hard hat, safety shoes and safety glasses, no loose clothing).
  - THE LOAD must be clear of other objects and free to move. Make sure the load will not tip, spin, roll away, or in any way move uncontrollably.
- 2.3.3 KNOW YOUR LOAD and make sure you do not exceed the load rating of the winch or any other equipment in the system.

## 2.4 Attaching the Load

### ⚠WARNING

Do not wrap the wire rope around the load. This damages the wire rope and could cause the load to escape. Use a sling or other approved rigging device.

- 2.4.1 CLEAR OBJECTS from the path of the load so you can move it freely and observe it at all times during the operation.
- 2.4.2 ATTACH THE LOAD using a nylon sling, or other approved rigging device. Follow the recommendations of the sling manufacturer.
- SEAT THE SLING in the saddle of the hook with the hook latch completely closed. See Figure 5.
  - CENTER THE LOAD on the hook so it will remain balanced and not tip or rotate to one side.

Figure 5 – Attaching Load

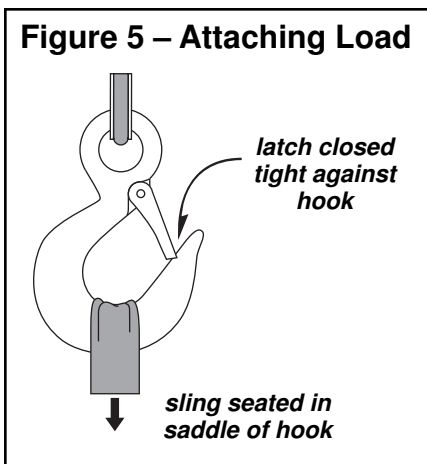

**Important!**

- Obey a stop signal from anyone.
- Maintain tension on the wire rope to keep it tightly and evenly wound on the drum.
- If the winch and load are not visible during the entire operation, get help from another person.
- Appoint a supervisor if more than one person is involved in the operation. This will reduce confusion and increase safety.
- When lifting a load, use a tag line to keep the load from swinging or twisting, while keeping yourself away from the load.

## 2.5 Moving the Load

- 2.5.1 **MOVE THE LOAD** slowly and smoothly, only a small distance at first. Make sure the load is balanced and securely attached before continuing.
- 2.5.2 **USE THE CONTROL DEVICE** to operate the winch. The control device should be momentary contact type, so the winch will stop when the operator releases the control.
- 2.5.3 **DO NOT EXCEED DUTY CYCLE RATING** of the winch. This equipment is rated for a 5 minute duty cycle.
- 2.5.4 **OBSERVE THE WIRE ROPE** as it winds onto the drum. If it becomes loose, uneven, or overlapped, stop the operation and rewind the wire rope before continuing. **Continued operation with overlapped or uneven wire rope can damage the wire rope and shorten its life.**
- 2.5.5 **ALLOW THE WINCH TO COOL DOWN** to ambient temperature in rest periods between operations.
- 2.5.6 **OBSERVE THE GEARBOX AND BRAKE** during operation for signs of overheating. **Frequent overheating may be a sign of damage, or may indicate the need for a larger winch.**
- a **WATCH FOR SMOKE**, the smell of burnt oil, and other signs of overheating. Use a thermocouple or other device to monitor gearbox temperature. The temperature of the oil should not exceed 150° F.
  - b **STOP THE OPERATION** if the gearbox or brake overheats, and allow the winch to cool until it reaches ambient temperature. **Continued operation may cause damage.**

## 2.6 Operating the Clutch

**Figure 6 – Operating the Clutch**

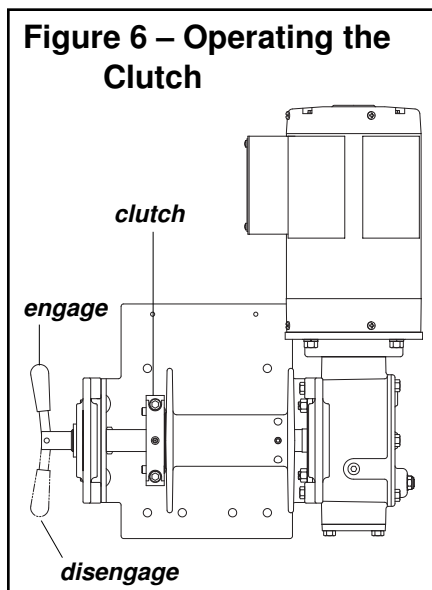

**⚠WARNING**

Do not engage or release the clutch while the winch drum is turning.

**Engage the clutch completely before operating the winch. Operating the winch with a released or partially engaged clutch may cause damage, or allow the load to escape.**

- 2.6.1 **RELEASE THE CLUTCH** with the clutch handle, and unwind the wire rope for hookup to the load. See Figure 6.
- 2.6.2 **ENGAGE THE CLUTCH** with the clutch handle. You may need to rotate the drum by hand to align the clutch jaws. **Visually inspect the clutch for complete engagement.**

---

## 2.7 Emergency Operation

(for models equipped with this feature)

**⚠WARNING**

**Do not adjust the brake with the load suspended. Accidental release of the brake could allow the load to escape.**

**Do not leave a suspended load unattended unless specific precautions have been taken to secure the load and keep unnecessary personnel away from the winch and from under the load.**

- 2.7.1 IN CASE OF POWER FAILURE, turn the control device to OFF and DISCONNECT electric power. Leave electric power DISCONNECTED.
- 2.7.2 MAKE SURE SAFETY PRECAUTIONS have been taken to secure the load and keep unnecessary personnel away from the winch and from under the load while operating the emergency hand crank.
- 2.7.3 IF EQUIPPED WITH A BRAKE MOTOR you must disengage the brake on the motor before using the emergency hand crank. Operating the emergency hand crank with the brake on the motor engaged could result in equipment damage or failure.
  - a It is recommended for two people to operate the winch using the emergency hand crank.
  - b If the winch is equipped with a brake motor, assign one person to operate the hand crank while the other is assigned to operate the brake. Have control of the hand crank before disengaging the brake on the motor. Accidental release of the brake could allow the load to escape.
  - c If the winch is not equipped with a brake motor, assign one person to operate the hand crank while the other is assigned to observe and control the load.
  - d Always follow the brake manufacturers operating instructions for engaging or disengaging the brake.
- 2.7.4 DO NOT USE AN IMPACT WRENCH to operate the emergency hand crank option of the winch. To do so could result in equipment damage or failure. Use a drill-motor.
- 2.7.5 DO NOT EXCEED THE 5 MINUTE DUTY CYCLE rating of the winch if operating with a drill-motor and do not operate the winch with a drill-motor that exceeds 400 rpm. To do so could result in equipment damage or failure.
- 2.7.6 ENGAGE THE BRAKE and remove the handle or drill-motor before operating the winch using electric power.

ANY QUESTIONS ON OPERATING THE EMERGENCY HAND CRANK OPTION OR WINCH APPLICATION CONTACT THERN, INC.

**Important!**

Increase the frequency of maintenance procedures if the winch is:

- Operated for long periods.
- Used to pull heavy loads.
- Operated in wet, dirty, hot, or cold surroundings.

## 3.1 Cleaning the Winch

Clean the winch to remove dirt and help prevent rust and corrosion.

- 3.1.1 CLEAN THE WINCH every 6 months or whenever it is dirty.
- WIPE ALL EQUIPMENT to remove dirt and grease.
  - LEAVE A LIGHT FILM of oil on all surfaces to protect them against rust and corrosion.
  - WIPE OFF excessive amounts of oil to avoid the accumulation of dirt.
- 3.1.2 REMOVE ALL UNNECESSARY OBJECTS from the area surrounding the winch.

## 3.2 Adjusting the Brake

**⚠WARNING**

**Do not adjust the brake with the load suspended. Accidental release of the brake could allow the load to escape.**

**Important!**

- Do not overtighten the brake, since this will cause parts to wear and become damaged.

**Figure 7a – Adjusting the Brake**

*turn brake adjusting nuts clockwise  
1/4 turn*

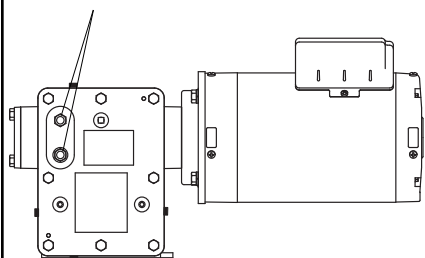

**Figure 7b – Adjusting the Brake**

*brake release knob*

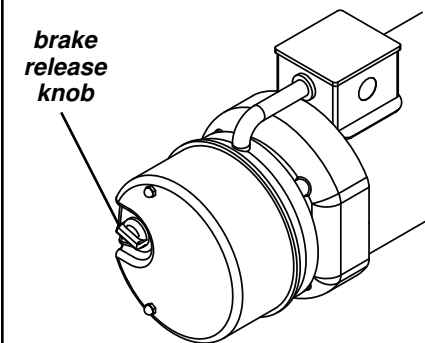

- 3.2.1 ADJUST THE BRAKE whenever it appears to need adjustment, or at least every 3 months.
- 3.2.2 CHECK THE ELECTRIC BRAKE ON THE MOTOR (if equipped) by operating the winch with a test load equal to the winch load rating.
- DISENGAGE THE ELECTRICAL BRAKE **under no load**. See Figure 7a.
  - RAISE THE LOAD, then lower it and stop it about one foot off the ground.
  - OBSERVE THE LOAD when stopped. If it continues to coast or creep, the brake needs adjustment. Refer to the brake manufacturer's instructions, or contact the factory for assistance.
  - RE-ENGAGE THE MECHANICAL BRAKE by following the instructions below.
- 3.2.3 CHECK THE MECHANICAL BRAKE on the 4WP2D series by operating with a test load equal to the winch load rating:
- DISENGAGE THE ELECTRICAL BRAKE (if equipped) **under no load**. Keep disengaged during procedures b and c below. See Figure 7b.
  - RAISE THE LOAD, then lower it and stop it about one foot off the ground.
  - OBSERVE THE LOAD when stopped. If it continues to coast or creep, follow the instructions below:
    - Tighten the brake by turning the adjusting nuts clockwise about 1/4 turn. Continue to test and tighten the brake by alternating the tightening of each brake nut until the brake stops and holds the load securely. See Figure 7b.
    - **DO NOT OVERTIGHTEN** mechanical brake adjusting nuts.
  - RE-ENGAGE THE ELECTRICAL BRAKE (if equipped).
- 3.2.4 A DECELERATION DISTANCE while stopping is typically 6 inches.
- 3.2.5 IF THE LOAD CONTINUES TO COAST or creep, contact the factory.

### 3.3 Lubricating the Winch

#### Important!

- Do not leave plug holes in the reducer open. Open plug holes will allow dirt and moisture to contaminate the lubrication.
- Make sure lubricant has a temperature rating appropriate for the ambient temperatures of the operation.

#### CAUTION

Make sure the breather is clean and open to vent heat and pressure. Poor ventilation may cause overheating and result in equipment damage.

Check the gearbox for proper level before operating. Too much or too little oil will cause overheating and result in equipment damage.

Lubricate the winch properly to help protect it from wear and rust. Read the following instructions carefully.

Figure 8 – Lubricating the Flange Bearing

*flange bearing, lubricate with NLGI no. 2 grease*

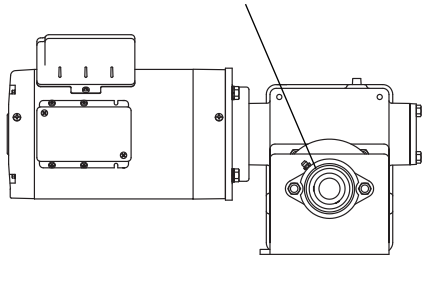

3.3.1 FOR 4WP2D SERIES, the winch is shipped from the factory with the proper amount (44 ounces) of Mobilgear 600 XP220 lubricant in the gearbox. Lubricate the winch as follows. See Figure 9.

3.3.2 MOTOR BEARINGS are typically lubricated for life by the manufacturer.

- a REPLACE MOTOR BEARINGS if the motor is disassembled for any reason.
- b REFER TO MOTOR MANUFACTURER'S INFORMATION for specific instructions regarding motor lubrication.

3.3.3 CHECK OIL LEVEL before every operation and every 10 hours during operation. Remove the level check plug and make sure oil is even with the plug hole. Add oil to the gearbox if necessary. **Do not use synthetic lubricants and do not mix different lubricants.** See Figure 9.

3.3.4 CHANGE GEARBOX OIL at least every 6 months, or whenever it is dirty or contaminated. Remove the drain plug to drain oil from the gearbox. See Figure 9.

3.3.5 LUBRICATE THE FLANGE BEARING at least once every month or more, depending on usage. Use a grease gun to insert NLGI no. 2 grease until clean grease appears at the seals. The bearing will squeak if it is dry. See Figure 8.

3.3.6 LUBRICATE THE WIRE ROPE and other equipment by following the manufacturers recommendations.

Figure 9 – Lubricating the Winch

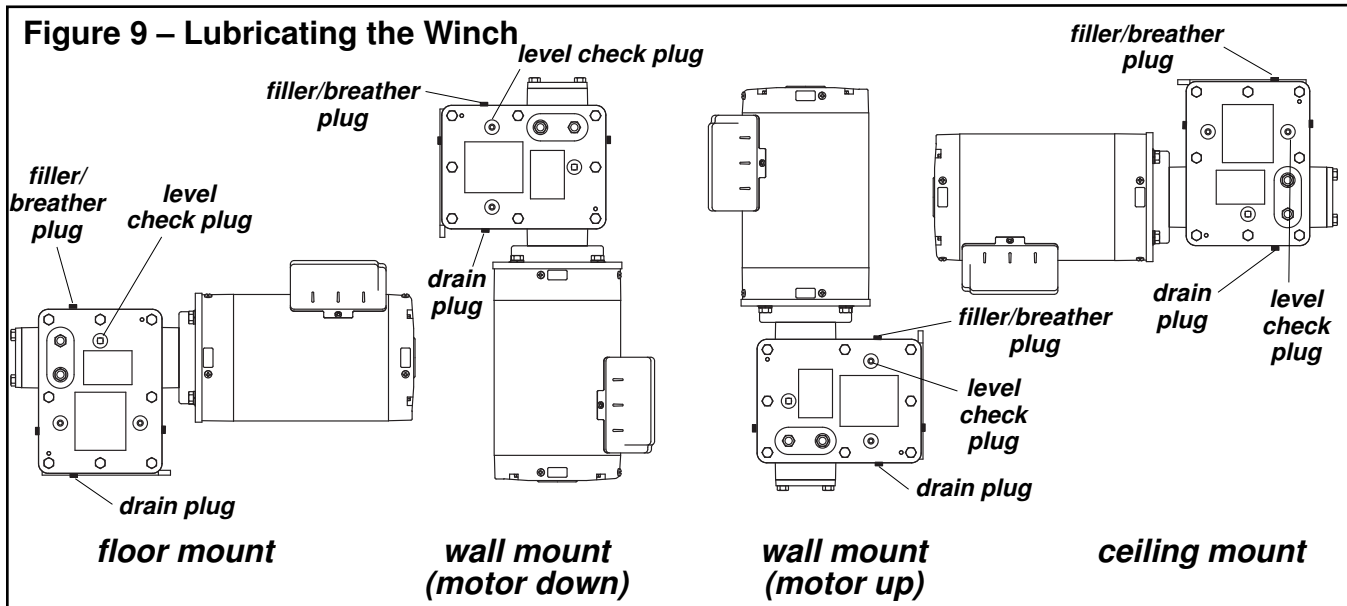

## 3.4 Inspecting the Equipment

### Important!

- Start an inspection program as soon as you put the winch into use.
- Appoint a qualified person to be responsible for regularly inspecting the equipment.
- Keep written records of inspection. This allows comparison with comments from previous inspections so you can see changes in condition or performance.

### Perform frequent inspections:

- Before each operation.
- Every 3 hours during operation.
- Whenever you notice signs of damage or poor operation.

**Figure 10 – Broken Wires**

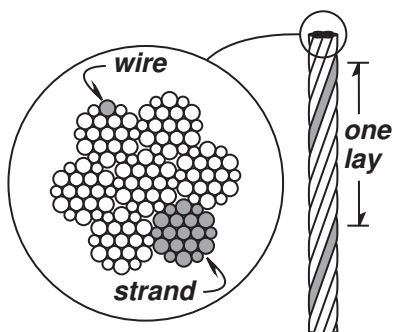

**Wire rope assembly must be replaced if more than 6 wires are broken in one lay, or if more than 3 wires are broken in one strand in one lay.**

### ⚠WARNING

**Do not use damaged or malfunctioning equipment. Place an “OUT OF ORDER” sign on the winch. Do not use the winch until the sign is removed by a qualified maintenance person who has completely corrected the problem.**

Inspect the winch to detect signs of damage or poor operation before they become hazardous.

3.4.1 CONSULT APPLICABLE CODES AND REGULATIONS for specific rules on inspecting the winch and other equipment.

3.4.2 CONSULT MANUFACTURER’S RECOMMENDATIONS for information on inspecting the wire rope and other equipment.

### 3.4.3 Instructions for Frequent Inspection

- a VISUALLY INSPECT the entire winch and all other equipment involved in the operation.
  - Check all equipment for cracks, dents, bending, rust, wear, corrosion and other damage.
  - Make sure the wire rope is installed correctly and anchored securely to the drum.
  - Make sure the winch is properly lubricated.
  - Check the gearbox for signs of leakage, and make sure it is filled with the proper lubricant. Contact the factory if there are any signs of lubricant leaking from the gearbox.
  - Make sure the breather plug is clean, open, and installed correctly.
  - Make sure mounting fasteners are tightened securely.
  - Make sure the foundation is in good condition, and capable of supporting the winch and its load under all load conditions.
  - Check electrical wiring and connections for wear, corrosion, cuts, and other damage.
  - Check clutch operation, if applicable, to make sure it moves freely and engages completely.
- b TEST WINCH PERFORMANCE by moving a test load equal to 10% of the rated capacity.
  - Listen for unusual noises, and look for signs of damage as you operate the winch.
  - Make sure the wire rope winds evenly and tightly onto the drum. If it is loose or uneven, rewind it before continuing.
  - Make sure the load moves smoothly, without hesitation or strain.
  - Make sure the winch responds to the control device. It must rotate as shown on the control labels, and it must turn off when you release the control.
  - Check the brake. Raise the load, then lower it and stop it a few feet off the ground. If the load continues to coast or creep, the brake needs adjustment. See Section 3.2 Adjusting the Brake.

**Completely correct all problems before continuing. Use the Troubleshooting Chart to help determine the cause of certain problems. See Table 2.**



**Perform periodic inspections:**

- Every 6 months.
- Whenever you return the winch to service from storage.
- Whenever you notice damage or poor operation in a frequent inspection.
- Whenever you have, or think you may have, overloaded or shock loaded the winch.

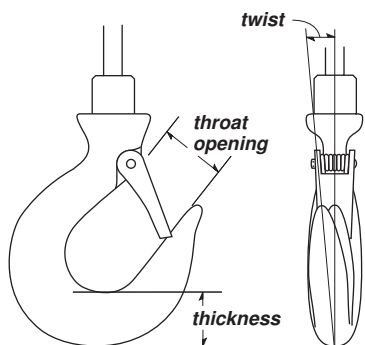
**Figure 11 – Load Hook Inspection**

**The wire rope assembly must be replaced if the throat opening is 15% wider than nominal, if the thickness is 10% less than nominal, or if the hook is twisted 10° or more.**

**3.4.4 Instructions for Periodic Inspection, see Table 1.****a VISUALLY INSPECT the winch and all other equipment.**

- Disassembly may be required in order to properly inspect individual components. Contact factory for assembly/disassembly instructions. Disassembly of the gearbox before contacting Thern, Inc voids all warranties.
- Check the finish for wear, flaking, or other damage.
- Check all equipment for cracks, dents, bending, rust, wear, corrosion and other damage. If the equipment was overloaded, or if you notice cracks and other signs of overloading and damage, promptly remove equipment from use and have it repaired or replaced. **DO NOT CONTINUE TO USE DAMAGED OR OVERLOADED EQUIPMENT.**
- Check all fasteners for stripped threads, wear, bending, and other damage.
- Check the gearbox for signs of leakage. Contact factory if there are any signs of lubricant leaking from the gearbox.
- Make sure the breather plug is clean, open and installed correctly.
- Make sure the winch outboard bearing is properly lubricated.
- Check clutch operation, if applicable, to make sure it moves freely and engages completely.
- Make sure all labels and plates are readable, firmly attached, free of damage and clean. Replacements are available from the factory.

**b DRAIN A SMALL AMOUNT OF OIL from the gearbox into a clean container.**

- Check the oil for dirt, metal particles, water, and other signs of contamination. Completely drain the gearbox if oil is contaminated.
- Make sure the gearbox is properly lubricated. See Section 3.3 Lubricating the Winch.

**c INSPECT THE WIRE ROPE according to the wire rope manufacture's recommendations, or follow accepted industry standards for wire rope inspection.**

- Always wear protective clothing when handling wire rope.
- Check the entire length of wire rope for bent wires, crushed areas, broken or cut wires, corrosion, and other damage. Carefully inspect areas that pass over sheaves or through roller guides.
- Note the location and concentration of broken wires. Replace wire rope if more than 6 wires are broken in one lay, or more than 3 wires are broken in one strand in one lay. See Figure 10.
- Make sure hooks and other fittings are securely attached to the wire rope, and the wire rope where they are attached is not frayed, corroded, broken, or otherwise damaged.
- Measure the throat opening, thickness, and twist of the hook. Replace the hook if it shows signs of damage. See Figure 11.
- Make sure any hook latches open without binding and close when released.
- Check the anchor holes in the drum and the surrounding area for signs of wear or distortion.

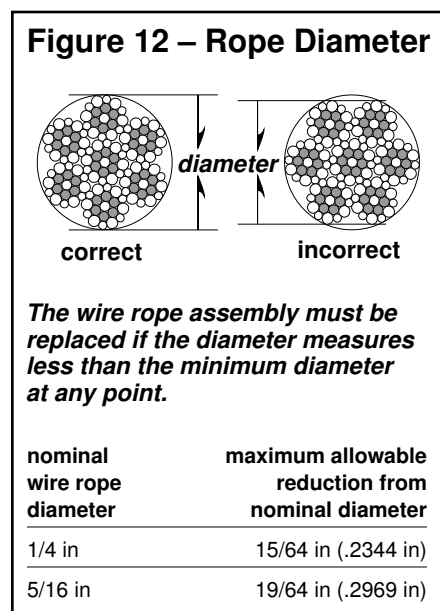

- d MOVE THE DRUM with your hands. Check for excessive movement indicating worn or loose gears, bearings, or shafts. Slight endplay in the driveshaft is normal. Excessive movement is caused by overloading or overheating, and is a sign that your application may require a larger winch.
- e PLACE 100 POUNDS of tension on the wire rope.
  - Measure the diameter of the wire rope, especially in areas where wear is noticeable. Replace the wire rope if the diameter measures below the minimum diameter at any point. See Figure 12.
- f INSPECT THE FOUNDATION AND RIGGING
  - Check mounting fasteners for stripped threads, wear, and other damage.
  - Check the foundation for cracks, corrosion, and other damage.
- g TEST WINCH PERFORMANCE by operating the winch with a test load equal to the load rating.
  - Listen for unusual noises, and look for signs of damage as you operate the winch.
  - Make sure the wire rope winds evenly and tightly onto the drum. If it is loose or uneven, rewind it before continuing.
  - Observe the rotating drum, look for signs of loose or misaligned bearings.
  - Make sure the load moves smoothly, without hesitation or strain.
  - Make sure the winch responds to the control device. It must rotate as shown on the control labels, and it must turn off when you release the control.
  - Check the brake. Raise the load, then lower it and stop it a few feet off the ground. If the load continues to coast or creep, the brake needs adjustment. See Section 3.2 Adjusting the Brake.
- h DISCONNECT POWER and inspect power supply equipment.
  - Check supply lines for wear, cuts, corroded connections, and other damage.
  - Check control devices and other power supply components for signs of moisture, corrosion, burn marks, cracks, and other damage.
- i CONNECT POWER.
  - Check power supply at the motor and make sure it agrees with the motor rating. Do not operate the winch until proper power is supplied to the motor.

**Completely correct all problems before continuing. Use the troubleshooting chart to help determine the cause of certain problems. See Table 2.**



**Table 2 – Troubleshooting Chart**

Contact the factory for detailed instructions on re-sealing the gearbox if you are required to disassemble the gearbox for any reason. Disassembly of the gearbox before contacting Thern, Inc. voids all warranties.

<b>problem</b>	<b>cause</b>	<b>correction</b>
<b>motor won't run</b>	<ul style="list-style-type: none"> <li>• circuit breaker tripped or fuse blown ..... reset circuit breaker or replace fuse</li> <li>• poor power supply ..... inspect and repair as necessary</li> <li>• power supply lines loose or damaged ..... inspect, repair and tighten as necessary</li> <li>• power supply failure ..... check power supply source</li> <li>• motor burnt out or damaged ..... repair or replace as necessary</li> </ul>	
<b>motor runs, drum doesn't turn</b>	<ul style="list-style-type: none"> <li>• loose or broken spring pins or keys ..... inspect and replace as necessary</li> <li>• clutch disengaged ..... stop motor and engage clutch</li> <li>• loose, stripped or broken gears ..... inspect and replace as necessary</li> </ul>	
<b>motor tries to turn but can't</b>	<ul style="list-style-type: none"> <li>• unit overheated ..... allow to cool</li> <li>• load too heavy ..... lighten load</li> <li>• poor power supply ..... inspect supply circuit and repair as needed</li> <li>• band brake too tight ..... loosen brake and readjust</li> <li>• brake broken or locked ..... inspect and replace as necessary</li> <li>• gears or bearings broken or locked ..... inspect and replace as necessary</li> </ul>	
<b>brake does not operate properly</b>	<ul style="list-style-type: none"> <li>• wire rope installed improperly ..... reinstall wire rope correctly</li> <li>• brake adjusted incorrectly ..... adjust brake</li> <li>• brake worn or damaged ..... inspect and replace as necessary</li> <li>• brake components seized up or damaged ..... inspect and repair as necessary</li> </ul>	
<b>lubricant leakage</b>	<ul style="list-style-type: none"> <li>• worn bearings ..... inspect and replace as necessary</li> <li>• oil seals leaking or damaged ..... inspect and replace as necessary</li> <li>• gaskets leaking or damaged ..... tighten fasteners or replace gasket</li> <li>• cracked or damaged reducer ..... inspect and repair as necessary</li> <li>• hydraulic equipment leaking or damaged ..... inspect and replace as necessary</li> </ul>	
<b>excessive end play on drive shaft</b>	<ul style="list-style-type: none"> <li>• loose or damaged keys or keyways ..... inspect and replace as necessary</li> <li>• excessively worn gears ..... inspect and repair as necessary</li> </ul>	
<b>excessive worn gears or bearings</b>	<ul style="list-style-type: none"> <li>• load too heavy ..... lighten load</li> <li>• poor lubrication of gears or bearings ..... inspect and lubricate as necessary</li> </ul>	
<b>overheating</b>	<ul style="list-style-type: none"> <li>• operated too long without rest ..... allow to cool</li> <li>• load too heavy ..... lighten load</li> <li>• poor lubrication ..... inspect and lubricate as necessary</li> <li>• breather plug clogged or damaged ..... clean or replace breather plug</li> <li>• bearing seized up ..... inspect and replace as necessary</li> </ul>	
<b>unusual noises</b>		
high pitched squeak	<ul style="list-style-type: none"> <li>• poor lubrication ..... inspect and lubricate as necessary</li> </ul>	
grinding noise	<ul style="list-style-type: none"> <li>• contaminated lubrication ..... drain, clean and lubricate the winch</li> <li>• broken gears or bearings ..... inspect and replace as necessary</li> </ul>	
whining motor	<ul style="list-style-type: none"> <li>• load too heavy ..... lighten load</li> <li>• motor overheated ..... allow to cool</li> <li>• motor bearings burnt out ..... replace motor or bearings</li> </ul>	
whistling noise	<ul style="list-style-type: none"> <li>• air leak in pneumatic equipment ..... inspect and repair as necessary</li> </ul>	
rattling noise	<ul style="list-style-type: none"> <li>• loose fasteners or setscrews ..... tighten all fasteners and screws</li> </ul>	
heavy thump during operation	<ul style="list-style-type: none"> <li>• contaminants in lubricant ..... drain, clean and lubricate the winch</li> <li>• loose setscrews or keys in gears or shafts ..... inspect and repair as necessary</li> </ul>	

---

## 3.5 Repairing the Winch

### Important!

- It is your responsibility to determine when to replace parts. When considering whether to continue using a part or to replace it, remember that replacing it is the best way to avoid further equipment damage.
- Replace spring pins, retaining rings, and oil seals whenever the winch is disassembled for inspection or repair.
- During reassembly, use loctite 598 Ultra Black to create a seal between the two halves of the gearbox and the input shaft. Contact factory for detailed instructions. Disassembly of the gearbox before contacting Thern, Inc voids all warranties
- Appoint a qualified person to be responsible for all repairs to the equipment.

- 3.5.1 GET FACTORY AUTHORIZATION for all repairs. Unauthorized repairs will void the warranty, and may lead to damage or failure of the winch.
- 3.5.2 REPLACE DAMAGED OR POORLY OPERATING PARTS with Thern repair parts.
- 3.5.3 REFINISH AREAS where the paint is worn or flaking. A good finish helps to protect against corrosion and weather damage.
  - a REMOVE THE FINISH from damaged areas, down to the bare metal.
  - b CLEAN THE AREA thoroughly.
  - c REPAINT with a high quality primer and finishing coat.
- 3.5.4 TO ORDER REPAIR PARTS, contact your local dealer. Include the following information when ordering:
  - model number
  - **serial number** (or code number)
  - part number
  - date purchased, and from whom
  - description of what happened, or what is wrong
  - your name and return address

---

## 4.1 Transporting the Winch

**Important!**

- Keep a record of what you ship, and when you send it.

- 4.1.1 REMOVE THE BREATHER PLUG and install a sealed oil plug to prevent the loss of lubrication during shipment.
- 4.1.2 PACK THE WINCH in an upright position for transport, using the original packaging materials, if possible.
  - a FASTEN THE WINCH to a wooden base using lag bolts, to keep it from moving during transport.
  - b SEAL THE WINCH in plastic with a desiccant to help protect it from rust, corrosion, and other damage.
  - c CONSTRUCT WOODEN SIDES and top to enclose the winch in a solid protective crate.
  - d PACK LOOSE PARTS in small boxes or ship separately.
- 4.1.3 INSPECT THE WINCH according to the Instructions for Periodic Inspection before installing it in a new location.

---

## 4.2 Storing the Winch

- 4.2.1 LUBRICATE THE WINCH as necessary, and make sure the breather plug is clean and properly installed. Add a rust preventative for long term storage.
- 4.2.2 SEAL THE WINCH in plastic with a desiccant to help protect it from rust, corrosion, and other damage.
- 4.2.3 STORE THE WINCH upright, in a cool clean place away from corrosive chemicals and moisture.
- 4.2.4 ROTATE THE DRUM PERIODICALLY to keep bearing and gears surfaces from becoming lacquered.
- 4.2.5 INSPECT THE WINCH according to the Instructions for Periodic Inspection before installing it for operation.
- 4.2.6 TEST INSULATION RESISTANCE in the motor to detect moisture damage. Refer to the motor manufacturer's instructions.
- 4.2.7 LUBRICATE THE WINCH PROPERLY prior to operation. See Section 3.3 Lubricating the Winch.

4WP2D Series Assembly			
item	description	part number	qty.
1 <sup>1</sup>	MOTOR	MTR4WP2D	1
2	KEY .188 X .188 X 1.375	A5178	1
3	CAPSCREW HEXHD .375-16NC X 1.000	A2922	4
4	HELSPRLK WASHER .375 X .683 X .094	A2926	4
5	REDUCER ASSEMBLY	D2595	1
6	HEX NUT .375-16NC	A3017	6
7	SETScrew SQHD .312-18NC X .875	A7703	1
8	DRUM	C3381	1
9	FRAME	D1913	1
10	CARRIAGE BOLT .375-16NC X 1.250	A7283	2
11	FLANGE BEARING	A7285	1
12	BREATHER PLUG .375-18NPT X .48	A3408	1
13	GROOVE PIN TYPE A .312 X 2.500	A7284	1
14	LABEL WARNING POINTS	A2655	1
15	LABEL WARNING KEEP HANDS AWAY FROM DRUM	A2659	2
16	LABEL WARNING DISCONNECT ELECTRIC POWER	A2256	1
17 <sup>2</sup>	LABEL REMOVE DRAIN PLUGS	A8338	1
18 <sup>2</sup>	LABEL DRAIN PLUG WITH ARROW	A8339	8
19	LABEL WARNING	A7406	1
20	LABEL WARNING DO NOT ADJUST BRAKE WHEN	A2658	1
21	LABEL NAMEPLATE	A5957	1

<sup>1</sup> Motor varies.  
<sup>2</sup> Some electric motors are equipped with screw plugs which are designed to be removed to provide drain holes.

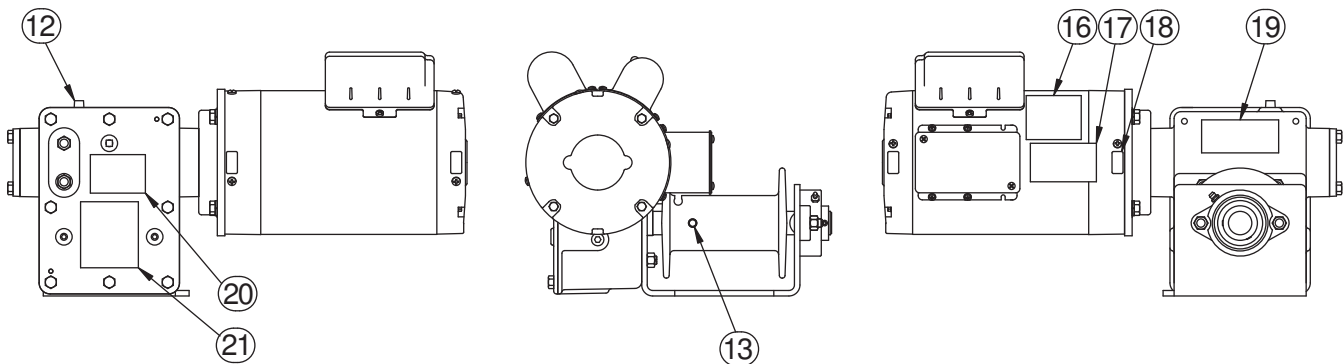
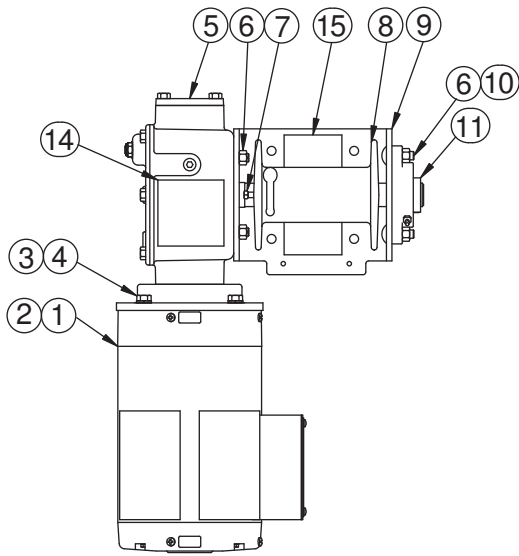



4WP2D8 Series Assembly			
item	description	part number	qty.
1 <sup>1</sup>	MOTOR	MTR4WP2D	1
2	KEY .188 X .188 X 1.375 4140	A5178	1
3	CAPSCREW HEXHD .375-16NC X 1.000	A2922	4
4	HELSPRLK WASHER .375 X .683 X .094	A2926	4
5	REDUCER ASSEMBLY	D2600	1
6	HEX NUT .375-16NC	A3017	6
7	SETSCREW SQHD .312-18NC X .875	A7703	1
8	DRUM	D2281	1
9	FRAME	D2248	1
10	BREATHER PLUG .375-18NPT X .48	A3408	1
11	CARRIAGE BOLT .375-16NC X 1.250	A7283	2
12	FLANGE BEARING 1.062	A7285	1
13	HANDLE	B3620	2
14	CAPSCREW HEXHD .312-18NC X 1.000	A3028	4
15	CAPSCREW HEXHD .312-18NC X .625	A3529	2
16	PRESSURE PLATE	B3861	1
17	GROOVE PIN TYPE A .312 X 2.500	A7284	1
18	LABEL WARNING POINTS	A2655	1
19	LABEL WARNING KEEP HANDS AWAY FROM DRUM	A2659	2
20	LABEL WARNING DISCONNECT ELECTRIC POWER	A2256	1
21 <sup>2</sup>	LABEL REMOVE DRAIN PLUGS	A8338	1
22 <sup>2</sup>	LABEL DRAIN PLUG WITH ARROW	A8339	8
23	LABEL WARNING	A7406	1
24	LABEL WARNING DO NOT ADJUST BRAKE WHEN	A2658	1
25	LABEL NAMEPLATE	A5957	1

<sup>1</sup> Motor varies.  
<sup>2</sup> Some electric motors are equipped with screw plugs which are designed to be removed to provide drain holes.

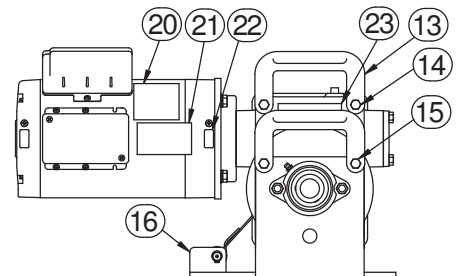
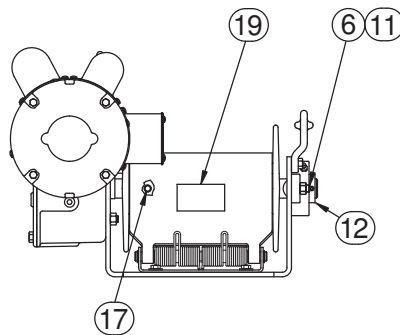
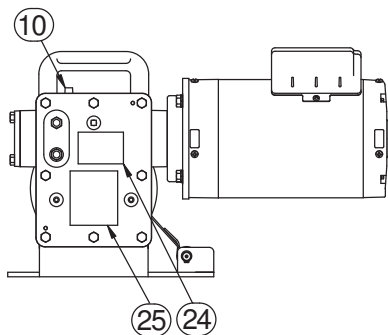
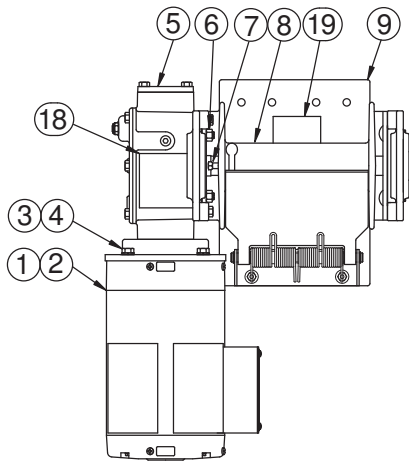

<b>4WP2DC Series Assembly</b>			
<b>item</b>	<b>description</b>	<b>part number</b>	<b>qty.</b>
1 <sup>1</sup>	MOTOR	MTR4WP2D	1
2	KEY .188 X .188 X 1.375	A5178	1
3	CAPSCREW HEXHD .375-16NC X 1.000	A2922	4
4	HELSPRLK WASHER .375 X .683 X .094	A2926	4
5	REDUCER ASSEMBLY	D2601	1
6	HEX NUT .375-16NC	A3017	6
7	SETSCREW SOKHD .312-18NC X .375	A3745	1
8	DRUM	D2337	1
9	FRAME	D2248	1
10	ZERK DRIVE .250	A3988	1
11	TOP CLUTCH	C3695	1
12	CAPSCREW SOKHD .375-16NC X 1.000	A3445	2
13	BEARING FLANGE 1.062	A7285	1
14	CARRIAGE BOLT .375-16NC X 1.250	A7283	2
15	PUSH PULL CLAMP	A7785	1
16	FLAT WASHER SAE .750 X 1.469 X .134	A6500	1
17	SPRING PLUNGER NYLK .375-16NC X 1.125	A7792	2
18	BOTTOM CLUTCH	C3697	1
19	HELSPRLK WASHER .312 X .586 X .078	A2925	1
20	CAPSCREW SOKHD .312-18NC X 1.250	A3548	1
21	GROOVE PIN TYPE A .312 X 2.500	A7284	1
22	CAPSCREW SOKFLTHD 10-24NC X 1.250	A7794	4
23	BREATHING PLUG .375-18NPT X .48	A3408	1
24	HANDLE	B3620	2
25	CAPSCREW HEXHD .312-18NC X 1.000	A3028	2
26	CLUTCH HUB	B3927	1
27	CAPSCREW HEXHD .312-18NC X .625	A3529	2
28	LABEL WARNING POINTS	A2655	1
29	LABEL WARNING KEEP HANDS AWAY FROM DRUM	A2659	2
30	LABEL WARNING DISCONNECT ELECTRIC POWER	A2256	1
31 <sup>2</sup>	LABEL REMOVE DRAIN PLUGS	A8338	1
32 <sup>2</sup>	LABEL DRAIN PLUG WITH ARROW	A8339	8
33	LABEL WARNING	A7406	1
34	LABEL CLUTCH DISENGAGED	A7842	1
35	LABEL CLUTCH ENGAGE	A7843	1
36	LABEL WARNING DO NOT ADJUST BRAKE WHEN	A2658	1
37	LABEL NAMEPLATE	A5957	1

<sup>1</sup> Motor varies.

<sup>2</sup> Some electric motors are equipped with screw plugs which are designed to be removed to provide drain holes.

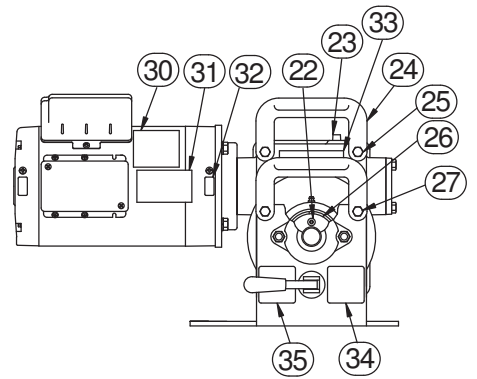
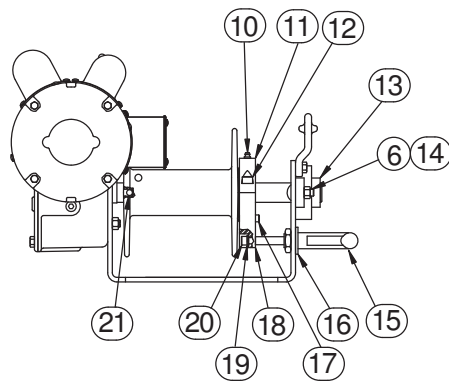
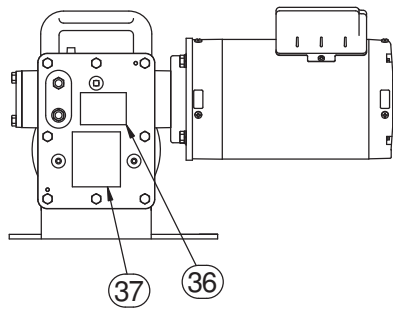
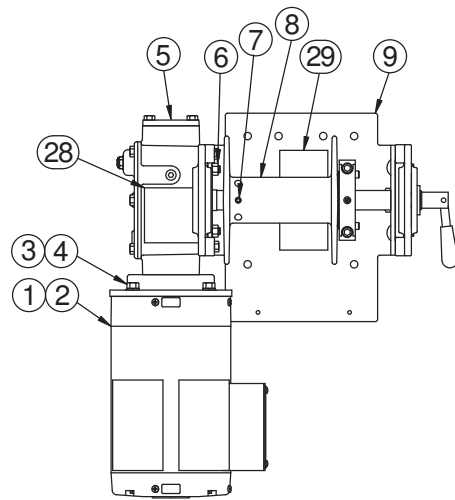

Reducer Assembly		D2595		D2600		D2601	
item	description	part number	qty.	part number	qty.	part number	qty.
1	CAPSCREW HEXHD .312-18NC X .750	A3032	12	A3032	12	A3032	12
2	BEARING HOUSING ASSEMBLY	B4265	1	B4265	1	B4265	1
3	THRUST BEARING .753ID X 1.250OD X .125	A8181	1	A8181	1	A8181	1
4	SHIM .751/.755 X 1.12 X .032	A8182	1	A8182	1	A8182	1
5	BRAKE DRUM ASSEMBLY	B4266	1	B4266	1	B4266	1
6	FLAT WASHER .781ID X 1.875OD X .090	A8184	2	A8184	2	A8184	2
7	FLAT WASHER .765ID X 1.254OD X .060	A8185	1	A8185	1	A8185	1
8	PIPE PLUG SQHD .125-27NPT X .35	A3407	1	A3407	1	A3407	1
9	DOWEL PIN .188 X .500	A7308	2	A7308	2	A7308	2
10	BALL THRUST BEARING	A8186	1	A8186	1	A8186	1
11	OIL SEAL 1.250ID X 1.687OD X .250	A8187	1	A8187	1	A8187	1
12	INPUT SHAFT	C3749	1	C3749	1	C3749	1
13	MOTOR MOUNT	D2594	1	D2594	1	D2594	1
14	PIPE PLUG HEXSOC .125-27NPT X .31	A3405	2	A3405	2	A3405	2
15	BRAKE BAND CONNECTOR	B2917	1	B2917	1	B2917	1
16	HEX JAM NUT NYLK .375-16NC	A3180	2	A3180	2	A3180	2
17	CAPSCREW HEXHD .312-18NC X 1.000	A3028	4	A3028	4	A3028	4
18	HELSPRLK WASHER .312 X .586 X .078	A2925	4	A2925	4	A2925	4
19	SPRING WASHER .380 X .750 X .034	A3296	1	A3296	1	A3296	1
20	COVER	D2052RED	1	D2052RED	1	D2052RED	1
21	GEARCASE	D2449RED	1	D2449RED	1	D2449RED	1
22	PIPE PLUG HEXSOC .375-18NPT X .425	A3290	4	A3290	4	A3290	4
23	OIL SEAL 1.125ID X 1.874OD X .250	A8188	1	A8188	1	A8188	1
24	STUD .375-16NC X 1.312	A7279	4	A7279	4	A7279	4
25	DRUM SHAFT ASSEMBLY	C3414	1	C3623	1	C3694	1

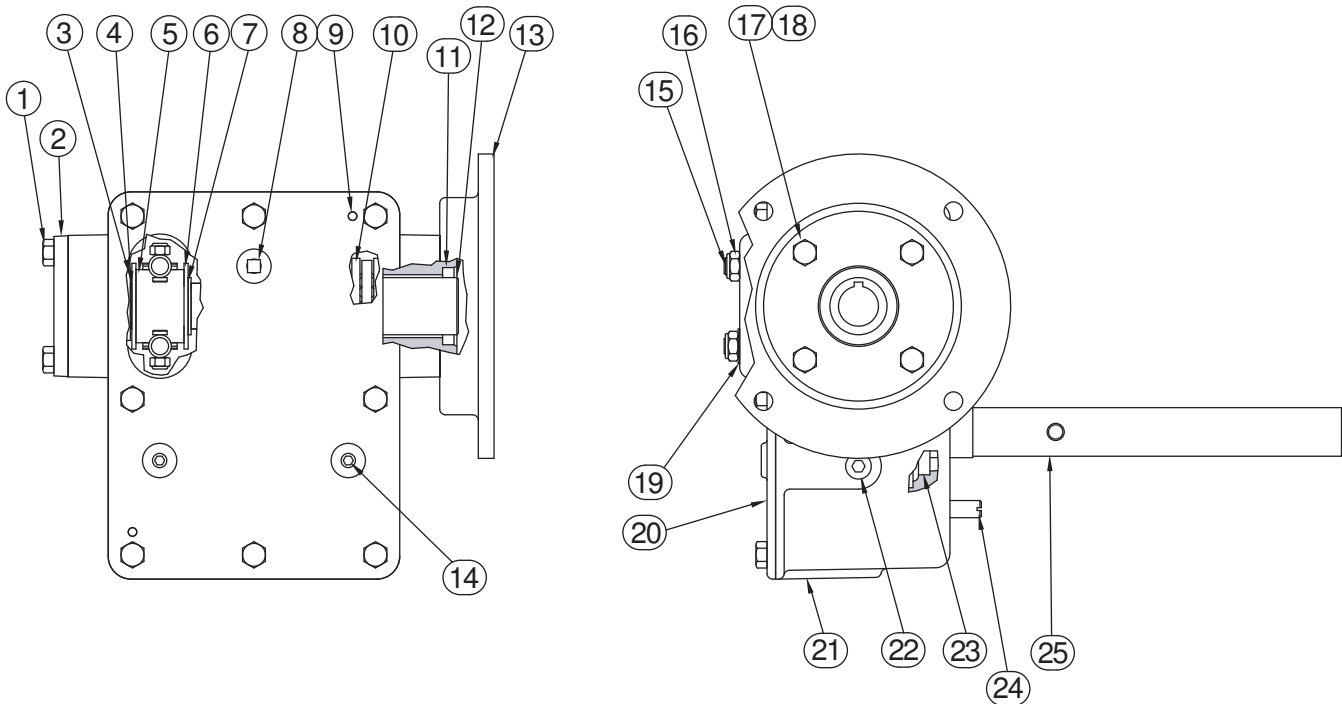

Pressure Plate Assembly		B3688 <sup>1</sup>		B3861 <sup>2</sup>	
item	description	part number	qty.	part number	qty.
1	PRESSURE PLATE	B3643	1	B3858	1
2	PIN	A3269	1	B3859	1
3	PRESSURE PLATE BASE	A3268	1	B3860	1
4	TORSION SPRING	A3277	1	A3277	2
5	SPACER TUBE	A3273	1	A3273	2
6	CAPSCREW HEXHD .250-20NC X .375	A7434	2	A7434	2
7	FLAT WASHER	—	—	A3052	2
8	RETAINING RING .500	A3278	2	A3278	2

<sup>1</sup> B3688 option for 4WP2D series winches – sold separately.  
<sup>2</sup> B3861 supplied with 4WP2D8 series winches.

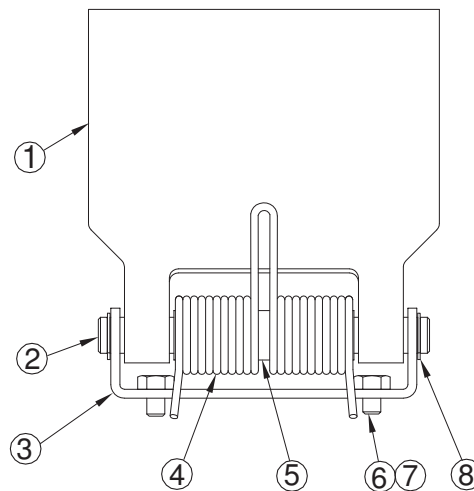

4WP2D Series – Performance Characteristics <sup>1</sup>													
model	motor codes	motor hp	load rating (lb)			wire rope dia. (in)	line speed (fpm)		drum capacity (ft) <sup>2</sup>			approx. ship wt. (lb)	
			1st layer	mid drum	full drum		1st layer	full drum	1st layer	mid drum	full drum		
4WP2D-800-26	A,B,D,E	1	800	590	460	1/4	26	45	11	35	77	75	
4WP2D-800-40	D,E	1.5	800	590	460	1/4	40	68	11	35	77	75	
4WP2D-1500-26	D,E	2	1500	1100	900	1/4	26	45	11	35	77	75	
4WP2D-1500-40	B,D,E	3	1500	1100	900	1/4	40	68	11	35	77	75	
4WP2D8-800-26	A,B,D,E	1	800	460	330	1/4	26	65	19	130	280	100	
4WP2D8-800-40	D,E	1.5	800	460	330	1/4	40	97	19	130	280	100	
4WP2D8-1500-26	D,E	2	1500	900	600	1/4	26	65	19	130	280	100	
4WP2D8-1500-40	B,D,E	3	1500	900	600	1/4	40	97	19	130	280	100	
4WP2DC-800-26	A,B,D,E	1	800	460	330	1/4	26	65	12	87	190	100	
4WP2DC-800-40	D,E	1.5	800	460	330	1/4	40	97	12	87	190	100	
4WP2DC-1500-26	D,E	2	1500	900	600	1/4	26	65	12	87	190	100	
4WP2DC-1500-40	B,D,E	3	1500	900	600	1/4	40	97	12	87	190	100	

<b>Motor Codes</b>	<p>A 115 volt 1 phase</p> <p>B 230 volt 1 phase</p> <p>D 230 volt 3 phase</p> <p>E 460 volt 3 phase</p>	<p><sup>1</sup> Performance Characteristics are for standard products referred to in this manual. Non-standard products may vary from the original design. Contact Thern, Inc. for this information.</p> <p><sup>2</sup> Actual drum capacities may be 25-30% less, due to nonuniform winding. Tension in wire rope will also affect drum capacity.</p>
--------------------	---	---



**Thern, Incorporated**  
5712 Industrial Park Road  
Winona, MN 55987

PH 507-454-2996  
FAX 507-454-5282

EMAIL: [info@thern.com](mailto:info@thern.com)  
[www.thern.com](http://www.thern.com)

**Thern Europe**  
Windmolen 22  
7609 NN Almelo  
Netherlands

PH +31-548-659-052

EMAIL: [europe@therneurope.eu](mailto:europe@therneurope.eu)