

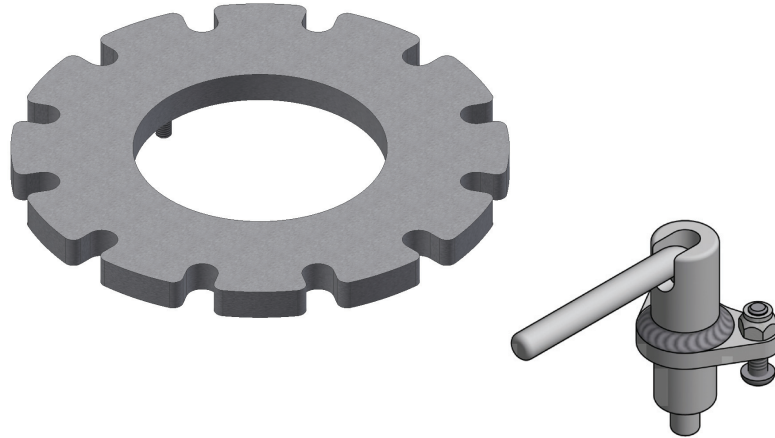

Read these instructions thoroughly before operating the equipment. Keep it with the equipment at all times. Replacements are available from Thern, Inc., 5712 Industrial Park Road, Winona, MN 55987, 507-454-2996. www.thern.com



ORIGINAL TEXT

Supplemental Instructions

For 5PA5LCK and 5PF5LCK Series Rotation Lock

These instructions are to serve as guidelines for hazard-free installation, operation, and maintenance. They should not be understood to prepare you for every possible situation.



A22283A-0518

Suggestions for Safe Operation

Keep these instructions readable and with the equipment at all times. Contact Thern, Inc. for replacements.

Check lubrication before use.

Keep all unnecessary personnel away from crane while in operation.

Do not exceed the load rating of the crane or any other component in the system. To do so could result in failure of the equipment.

Do not use damaged or malfunctioning equipment. To do so could result in failure of the equipment.

Do not modify the equipment in any way. To do so could cause equipment failure.

Do not use components for any use other than for their original intended function.

Do not use the rotational lock while the crane is being transported or while the boom may be subjected to side forces. To do so could result in failure of the equipment.

Important!

- Inspect the crane during assembly according to the Instructions for Periodic Inspection. This will give you a record of the condition of the crane with which to compare future inspections.
- Contact the factory immediately if any parts are missing or damaged.

Important!

Increase the frequency of maintenance procedures if the crane is:

- Operated for long periods.
- Used to lift heavy loads.
- Operated in wet, dirty, hot, or cold surroundings.

1.1 Installation and Assembly

- 1.1.1 **INSTALL THE BASE.** Refer to crane owner's manual for additional information and crane overturning moments and mounting bolt reaction forces.
- 1.1.2 **INSTALL THE PLATE** on the base. Position the plate so that the alignment pin and notch in base are aligned. **Plate must set level on base. See Figure 1.**
- 1.1.3 **INSTALL THE FLANGE BEARING** in the base. Bearing must be set level on the plate.
- 1.1.4 **FASTEN THE LOCK** to the mounting plate on the mast using the fasteners provided. Nut should be on top, closest to lock handle. See Figure 1. Do not overtighten fasteners, this may strip threads or cause damage to other parts.
- 1.1.5 **INSTALL THE MAST** in the base. Move the mast side-to-side to make sure the bottom of the mast properly seats on the pin in the bottom of the base. **The crane will not be stable unless properly seated. See Figure 1.**
- 1.1.6 **ASSEMBLE THE CRANE** following the steps outlined in the crane owner's manual.

CAUTION Do not use the rotational lock while the crane is being transported or while the boom may be subjected to side forces. The rotational lock is intended only as an aid for positioning and stability during operation or storage. To secure the crane in other conditions, it is recommended to attach the load hook to a suitable structure and take up the slack using the crane's winch or hoist being careful not to overload the crane.

