

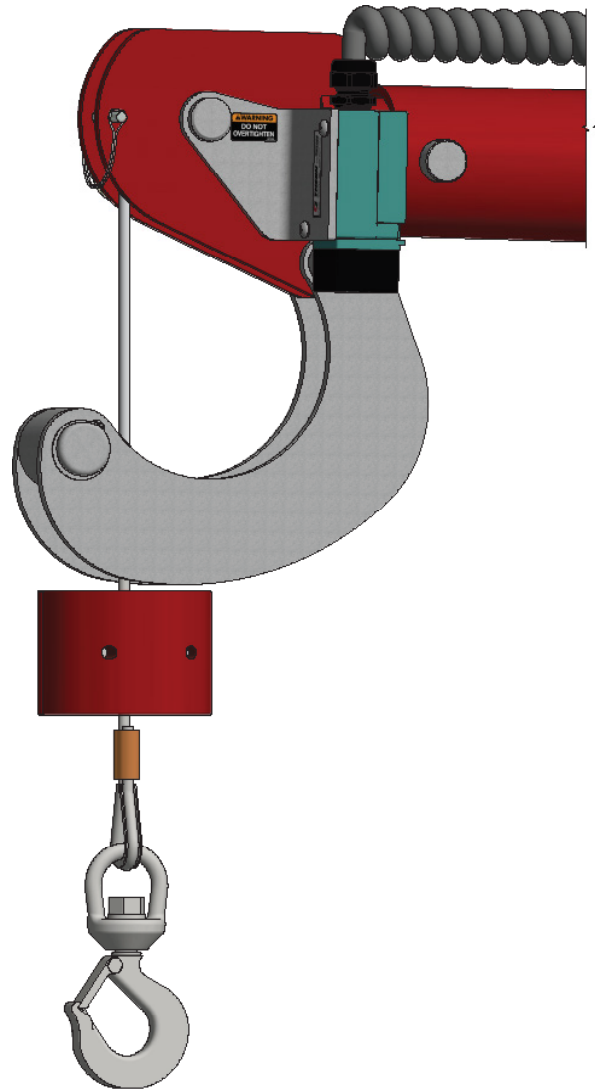

Read these instructions thoroughly before operating the equipment. Keep it with the equipment at all times. Replacements are available from Thern, Inc., 5712 Industrial Park Road, Winona, MN 55987, 507-454-2996. www.thern.com

ORIGINAL TEXT



Supplemental Instructions

For 5PxLS Series
Upper Travel Limit Switch



These instructions are to serve as guidelines for hazard-free installation, operation, and maintenance. They should not be understood to prepare you for every possible situation.

Suggestions for Safe Operation

⚠WARNING

DO the following:

Read and comply with the guidelines set forth in the Owner's Manual and this supplement. Keep the manual and this supplement, and all labels attached to the crane, readable and with the equipment at all times. Contact Thern, Inc. for replacements.

DO NOT do the following:

Do not use components for any use other than for their original intended function.

Important!

- Inspect the crane during assembly according to the Instructions for Periodic Inspection. This will give you a record of the condition of the crane with which to compare future inspections.
- Contact the factory immediately if any parts are missing or damaged.

Important!

Increase the frequency of maintenance procedures if the crane is:

- Operated for long periods.
- Used to lift heavy loads.
- Operated in wet, dirty, hot, or cold surroundings.

1.1 Installation and Assembly

- 1.1.1 ASSEMBLE THE CRANE following the steps outlined in the crane owner's manual.
- 1.1.2 ATTACH THE LIMIT SWITCH to the crane. See figure 1.
 - a Remove all loads attached to the crane.
 - b Attach the limit switch arm assembly to the crane using the longer threaded clevis pin supplied with the kit. Do not overtighten the nut. Arm should rotate freely without being loose. See figure 2.
 - c Remove the clevis pin holding the sheave at the end of the boom. Save the clevis pin for future use if the crane will ever be operated without the limit switch.
 - d Attach the limit switch and mounting bracket to the crane using the shorter threaded clevis pin supplied with the kit. Do not overtighten the nut. Sheave should rotate freely. See figure 2.
 - e Adjust the position of the switch so that the switch activates with a minimal amount of limit switch arm movement. See figure 1. This will allow the most distance possible for the load to decelerate and stop.
 - f Attach a Thern, Inc. headache ball (sold separately) to the wire rope between the load hook and switch arm. The headache ball is what makes contact with the switch arm and causes it to rotate.
 - g Remove limit switch connector plug at the winch motor (part number A20403). Save the connector for future use if the crane will ever be operated without the limit switch. See figure 3.

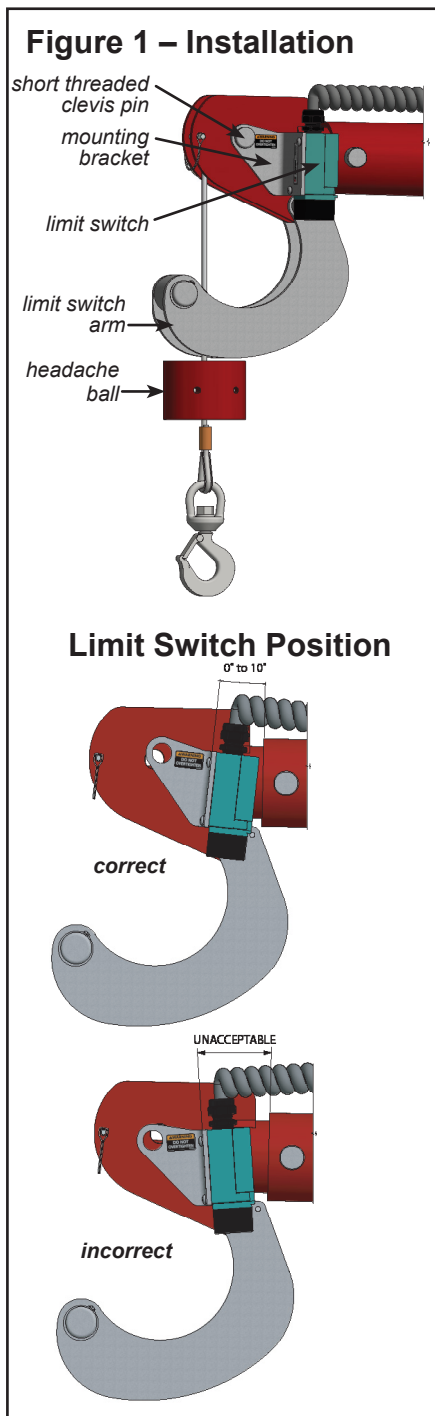

- h Pull the electrical cord from the switch to the winch motor. Safely position the cord such that crane operation will not be affected.
- i Connect the electrical cord from the limit switch to the connector at the winch motor.
- j Test operation of the winch and limit switch to ensure proper operation. **IMPORTANT:** Hold the limit switch override to lower load after tripping limit

1.2 Inspecting the Equipment

⚠WARNING

Do not use damaged or malfunctioning equipment. Place an “OUT OF ORDER” sign on the crane. Do not use the crane until the sign has been removed by a qualified person who has completely corrected the problem.

Inspect the crane to detect signs of damage or poor operation before they become hazardous. Refer to the steps outlined in the crane owner’s manual.

Completely correct all problems before continuing. Use the troubleshooting chart to help determine the cause of certain problems. See Table 1.

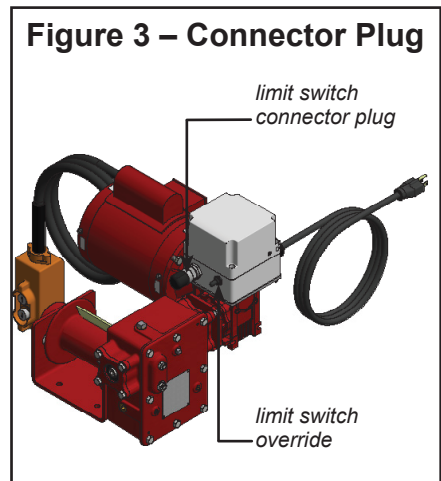
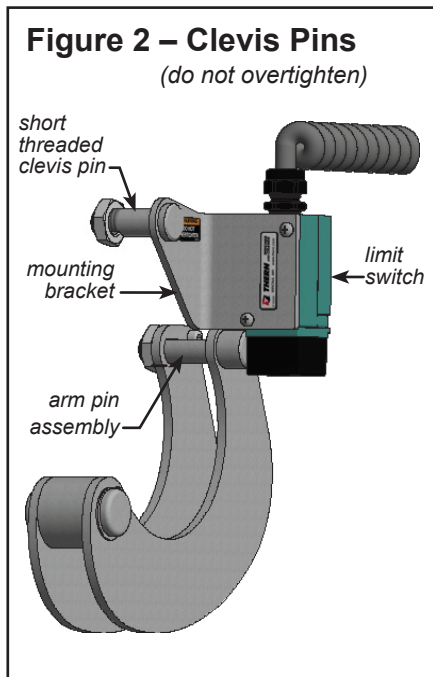

Table 1 – Troubleshooting Chart

problem	cause	correction
winch does not operate	poor electrical connections	inspect and repair as necessary
	limit switch in tripped position	inspect and adjust as necessary use limit switch override
	damaged switch	inspect and replace as necessary
	limit switch not properly connected to the motor connector	inspect and replace as necessary
limit switch does not stop the winch	poor contact with headache ball	inspect and adjust as necessary
	switch arm not positioned correctly	inspect and adjust as necessary
	damaged switch	inspect and replace as necessary

Refer to the Winch Owner’s Manual for possible problems with the winch and brake.

ITEM	PART NUMBER	QTY	DESCRIPTION
1	SEE TABLE	1	BRACKET LIMIT SWITCH
2	SEE TABLE	2	ARM LIMIT SWITCH
3	SEE TABLE	1	LIMIT SWITCH PIN ARM
4	SEE TABLE	1	LIMIT SWITCH
5	SEE TABLE	1	PINSHEAVE LIMIT SWITCH
6	SEE TABLE	1	NUT HEX JAM NYLK SST
7	SEE TABLE	1	WASHER FLT SST
8	A20974	1	NUT HEX JAM NYLK .750-10NC SST 18-8
9	A20973	2	CAPSCR SOKHD .250-20NC X .250 18-8 SST
10	A3892	2	RING RET EXT 1.250 SST
11	A21056	1	SWITCH LIMIT HI CAPACITY LSQ 20AMP
12	A20334	2	MACHSCR PANHDPHL 10-32NC X .500 SST
13	A3934	2	WASHER HELSPRLK #10 X .337 X .047 SST
14	A21488	1	SEALCON STRAIN RELIEF 1/2 NPT .39-.55 BL
15	A21241	1	RECEPTACLE MALE 3 PIN COILED CORDSET
16	A5531	3	TERMINAL RING NON-INSUL #10 X 10-12 GA
17	A14588	1	LABEL THERN WINCHES AND CRANES
18	A21030	2	LABEL DO NOT OVERTIGHTEN

	5PF5 / 5PT5	5PA5	5PA10	5PT10	5PT20	5PT30
ITEM						
1	A20957	A20958	A20959	A20960	A20961* A24526*	A20962
2	A20963	A20964	A20965	A21007	A20966	A20967
3	A20288	A20289	A20289	A20288	A20288	A20289
4	A20968	A20969	A20969	A20968	A20968	A20969
5	A20971	A20970	A20970	A20971	A20971	A20972
6	A20974	A20974	A20974	A20974	A20974	A20975
7	A9867	A9867	A9867	A9867	A9867	A21430

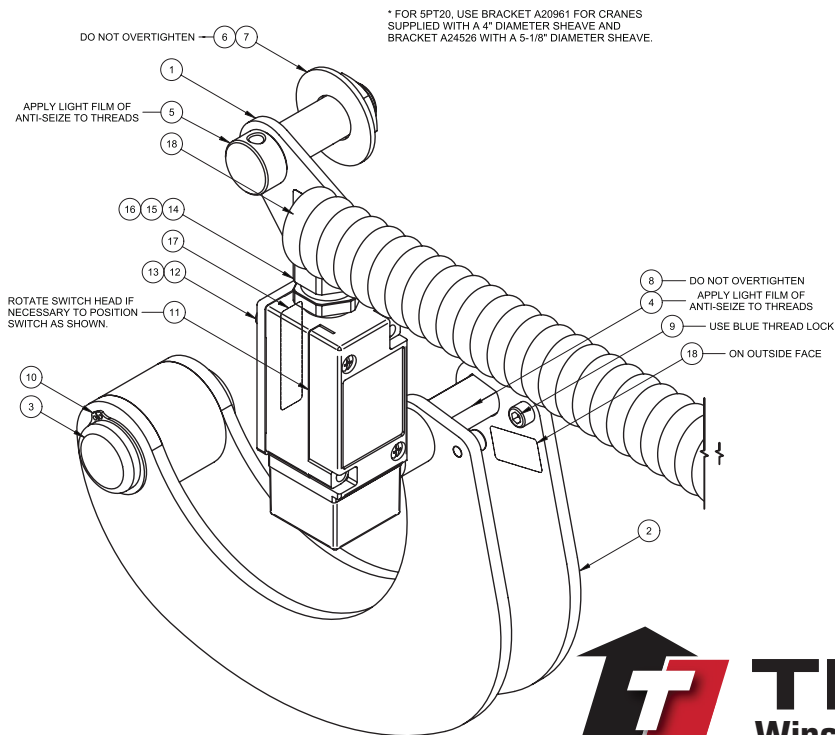

Thern, Incorporated
World Headquarters & Manufacturing
5712 Industrial Park Rd
Winona, MN USA 55987
TF: 1-800-843-7648 P: 1-507-454-2996
www.thern.com

Thern Europe BV
Regional Headquarters
Amsterdam Schiphol Tetra
Siriusdreef 17-27, 2132 WT
Hoofddorp
The Netherlands