



Read this Owner's Manual thoroughly before operating the equipment. Keep it with the equipment at all times. Replacements are available from Thern, Inc., PO Box 347, Winona, MN 55987, 507-454-2996.

IMPORTANT: Please record product information on page 2. This information is required when calling the factory for service.



Owner's Manual

For The
Model MB441, MB451, and MB491
Hand Operated Disc Brakes

Two-Year Limited Warranty

Please record the following:

Date Purchased:

Model No.:

Code No.:

This information is required when calling the factory for service.

Thern, Inc. warrants its products against defects in material or workmanship for two years from the date of purchase by the original using buyer, or if this date cannot be established, the date the product was sold by Thern, Inc. to the dealer. To make a claim under this warranty, contact the factory for an RGA number. The product must be returned, prepaid, directly to Thern, Inc., 5712 Industrial Park Road, Winona, Minnesota 55987. The following information must accompany the product: the RGA number, the date of purchase, the description of the claimed defect, and a complete explanation of the circumstances involved. If the product is found to be defective, it will be repaired or replaced free of charge, and Thern, Inc. will reimburse the shipping cost within the contiguous USA.

This warranty does not cover any damage due to accident, misuse, abuse, or negligence. Any alteration, repair or modification of the product outside the Thern, Inc. factory shall void this warranty. This warranty does not cover any costs for removal of our product, downtime, or any other incidental or consequential costs or damages resulting from the claimed defects. This warranty does not cover brake discs, as these are wear components and their life is subject to use conditions which vary between applications.

FACTORY AUTHORIZED REPAIR OR REPLACEMENT AS PROVIDED UNDER THIS WARRANTY IS THE EXCLUSIVE REMEDY TO THE CONSUMER. THERN, INC. SHALL NOT BE LIABLE FOR ANY INCIDENTAL OR CONSEQUENTIAL DAMAGES FOR BREACH OF ANY EXPRESS OR IMPLIED WARRANTY ON THIS PRODUCT. EXCEPT TO THE EXTENT PROHIBITED BY APPLICABLE LAW, ANY IMPLIED WARRANTY OF MERCHANTABILITY OR FITNESS FOR A PARTICULAR PURPOSE ON THIS PRODUCT IS LIMITED IN DURATION TO THE DURATION OF THIS WARRANTY.

Some states do not allow the exclusion or limitation of incidental or consequential damages, or allow limitations on how long an implied warranty lasts, so the above limitation or exclusion may not apply to you. This warranty gives you specific legal rights, and you may also have other rights which vary from state to state.

Note: Thern, Inc. reserves the right to change the design or discontinue the production of any product without prior notice.

About This Manual

The Occupational Safety and Health Act of 1970 states that it is the employer's responsibility to provide a workplace free of hazard. To this end, all equipment should be installed, operated, and maintained in compliance with applicable trade, industrial, federal, state, and local regulations. It is the equipment owner's responsibility to obtain copies of these regulations and to determine the suitability of the equipment to its intended use.

This Owner's Manual, and warning labels attached to the equipment, are to serve as guidelines for hazard-free installation, operation, and maintenance. They should not be understood to prepare you for every possible situation.

The information contained in this manual is applicable only to the Thern Model MB441, MB451, and MB491 Hand Operated Disc Brakes. Do not use this manual as a source of information for any other equipment.

The following symbols are used for emphasis throughout this manual:

▲WARNING

Failure to follow 'WARNING!' instructions may result in equipment damage, property damage, and/or serious personal injury.

▲CAUTION

Failure to follow 'CAUTION!' instructions may result in equipment damage, property damage, and/or minor personal injury.

Important!

Failure to follow 'important!' instructions may result in poor performance of the equipment.

Suggestions for Safe Operation

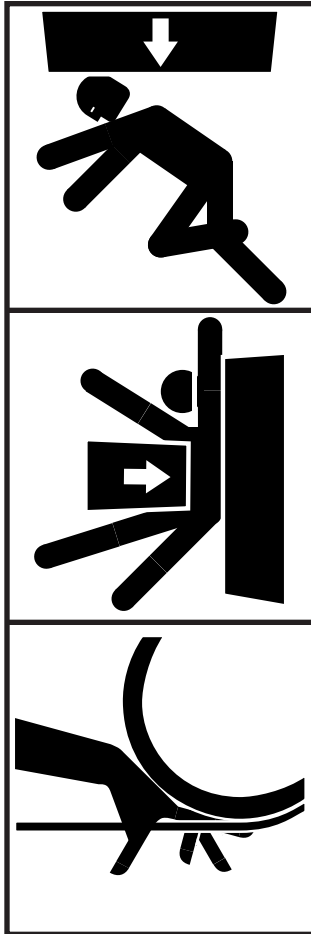
**▲WARNING****DO the following:**

Read and comply with the guidelines set forth in this Owner's Manual. Keep this manual, and all labels attached to the equipment, readable and with the equipment at all times. Contact Thern, Inc. for replacements.

Keep all people, including operators and yourself, away from the equipment. Keep out of the path of the load, and out of the path of a broken wire rope that might snap back and cause injury.

Keep hands away from moving parts of the equipment.

DO NOT do the following:

Do not lift people, or things over people. Do not walk or work under a load or in the line of force of any load.

Do not exceed the load rating of the equipment or any other component in the system. To do so could result in failure of the equipment.

Do not use damaged or malfunctioning equipment. To do so could result in failure of the equipment.

Do not modify the equipment in any way. To do so could cause equipment failure.

Do not divert your attention from the operation. Stay alert to the possibility of accidents, and try to prevent them from happening.

Do not jerk or swing the load. Avoid shock loads by starting and stopping the load smoothly. Shock loads overload the equipment and may cause damage.

Do not leave a suspended load unattended. Place the load on the ground before leaving it unattended.

1.1 Installing the Disc Brake

Important!

- Inspect the disc brake prior to installation according to the instructions contained in this manual.
- Make sure you receive all parts. Check the parts list at the back of this manual. Contact the factory immediately if any parts are missing or damaged.
- Do not overtighten fasteners, this may strip threads or cause damage to other parts.

Figure 1 – Adjusting Brake Handle Length

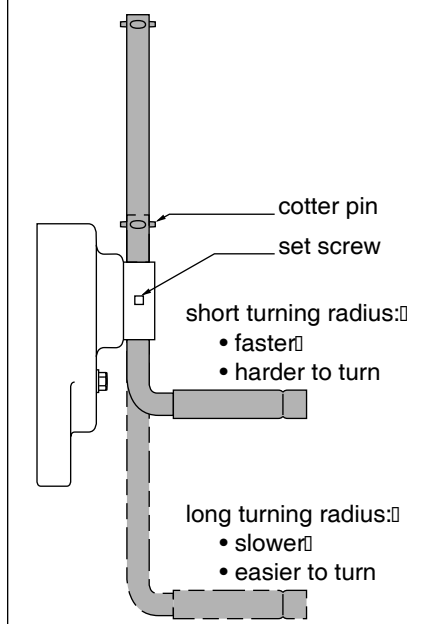

⚠ WARNING

Install the disc brake so it is securely attached to the hand winch, with the brake retainer, cotter pin, or hair pin clip securely in place as shown. A poorly installed brake could come loose and allow the load to fall.

- 1.1.1 REFER TO THE HAND WINCH OWNER'S MANUAL for information regarding winch installation. This Disc Brake Owner's Manual does not include instructions for installing the winch.
- 1.1.2 **Model MB441 – Disc Brake Installation. See figure 2.**
- REMOVE THE HAIR PIN COTTER and remove the winch handle.
 - REMOVE THE BRAKE RETAINER by removing the capscrew and lock washer.
 - SLIDE THE DISC BRAKE onto the drum shaft so the open hole in the brake housing slides onto the countershaft.
 - PLACE THE MACHINERY BUSHING on the countershaft, install the cotter pin, and bend the arms back to secure it in place. See figure 3.
 - REINSTALL THE BRAKE RETAINER using the capscrew and lock washer. **Make sure the long end is positioned behind the gear guard on the winch.**
 - REMOVE THE COTTER PIN from the handle and slide the handle through the holes in the drive assembly.
 - ADJUST HANDLE LENGTH and tighten the set screw. See figure 1.
 - INSTALL THE COTTER PIN in the handle, and bend the arms back to secure it in place. See figure 3.

Figure 2 – Model MB441 Installation

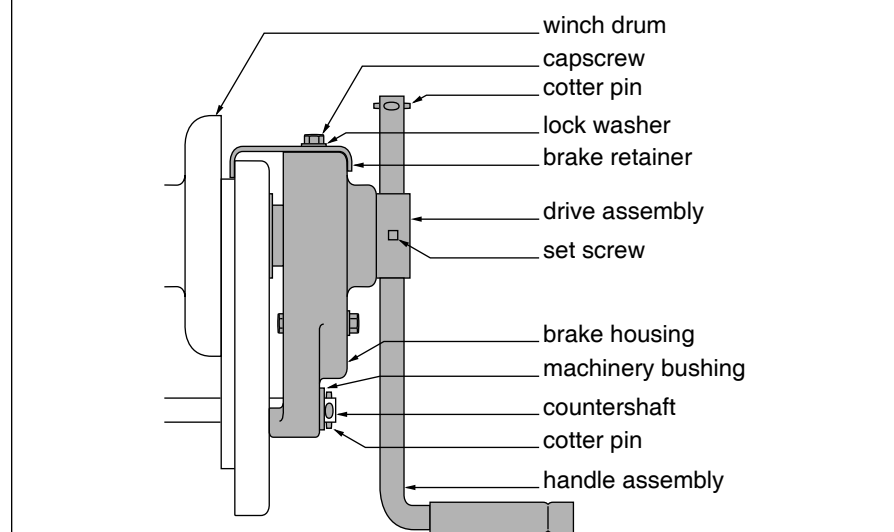
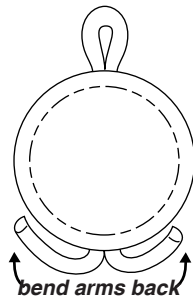

Figure 3 – Cotter Pins



1.1.3 Model MB451 and MB491 - Disc Brake Installation. See figure 4.

- a REMOVE THE HAIR PIN CLIP from the drum shaft of the winch, and remove the winch handle.
- b SLIDE THE DISC BRAKE onto the drum shaft so that the open hole in the brake housing slides onto the countershaft.
- c INSTALL THE HAIR PIN CLIP in the groove on the countershaft.
- d ADJUST HANDLE LENGTH and tighten the set screw. See figure 1.
- e BEND COTTER PIN ARMS back to secure it in place. See figure 3.

Figure 4 – Model MB451 and MB491 Installation

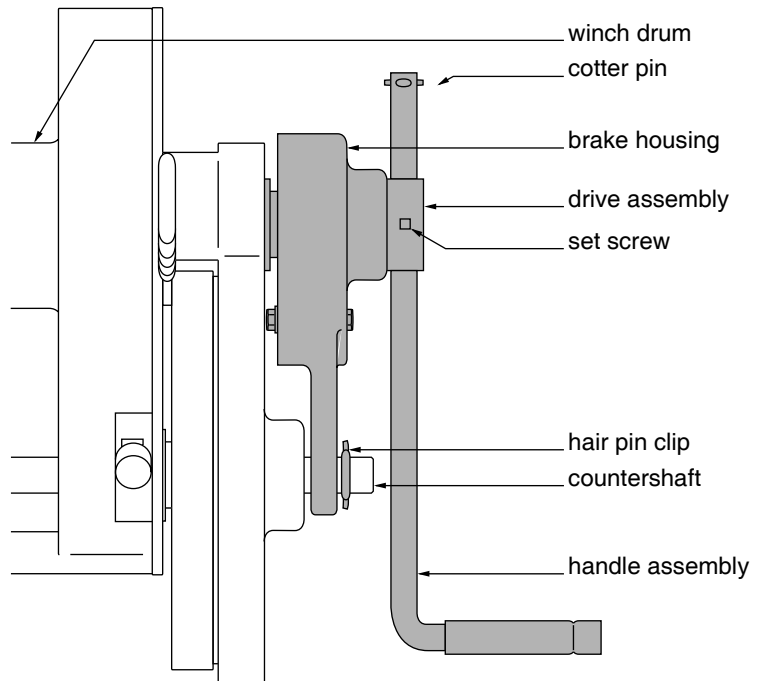

2.1 General Theory of Operation

Important!

- It is your responsibility to detect and account for different factors affecting the condition and performance of the equipment.

- 2.1.1 THE DISC BRAKE IS REQUIRED on all hand winches used to lift loads or pull loads on an incline.
- 2.1.2 INTERNAL FRICTION DISCS allow you to raise and lower the load by turning the brake handle. When the handle is released the friction discs tighten to hold the load in place.
- 2.1.3 DUTY RATINGS refer to the type of use the equipment is subject to. Consider the following when determining duty rating.
- a ENVIRONMENT: harsh environments include hot, cold, dirty, wet, corrosive, or explosive surroundings. **Protect the equipment from harsh environments when possible.**
 - b MAINTENANCE: poor maintenance, meaning poor cleaning, lubrication, or inspection, leads to poor operation and possible damage of the equipment. **Minimize poor maintenance by carefully following the instructions contained in this manual.**
 - c LOADING: severe loading includes shock loading and moving loads that exceed the load rating of the equipment. **Avoid shock loads, and do not exceed the load rating of the equipment.**
 - d FREQUENCY OF OPERATION: frequent or lengthy operations increase wear and shorten the life span of gears, bearings, and other components. **Increase maintenance of the equipment if used in frequent operations.**

CONTACT THE FACTORY FOR MORE INFORMATION.

2.2 Preparing for Operation

▲WARNING

DO the following:

Read and comply with the guidelines set forth in this Owner's Manual. Keep this manual, and all labels attached to the equipment, readable and with the equipment at all times. Contact Thern, Inc. for replacements.

DO NOT do the following:

Do not use damaged or malfunctioning equipment. To do so could result in failure of the equipment.

Do not modify the equipment in any way. To do so could cause equipment failure.

- 2.2.1 REFER TO THE HAND WINCH OWNER'S MANUAL for information regarding winch operation. This Disc Brake Owner's Manual does not include instructions for operating the winch.
- 2.2.2 CONSIDER THE OPERATION. Do not begin until you are sure you can perform the entire operation without hazard.
- 2.2.3 INSPECT ALL COMPONENTS of the system.
 - a INSPECT THE DISC BRAKE according to the instructions contained in this manual.
 - b INSPECT THE HAND WINCH and other equipment by following the instructions contained in the Hand Winch Owner's Manual.
 - c OPERATORS must be in good health, alert, thoroughly trained in operating the equipment, and properly clothed (hard hat, safety shoes and safety glasses, no loose clothing).
 - d THE LOAD must be clear of other objects and free to move. Make sure the load will not tip, spin, roll away, or in any way move uncontrollably.
- 2.2.4 KNOW YOUR LOAD and make sure you do not exceed the load rating of the equipment.

2.3 Operating the Disc Brake

Figure 5 – Operation

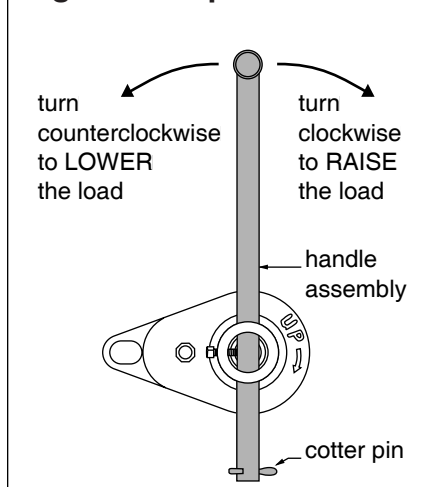

⚠ WARNING

DO the following:

Keep all people, including operators and yourself, away from the equipment. Keep out of the path of the load, and out of the path of a broken wire rope that might snap back and cause injury.

Keep hands away from moving parts of the equipment.

DO NOT do the following:

Do not lift people, or things over people. Do not walk or work under a load or in the line of force of any load.

Do not exceed the load rating of the equipment or any other component in the system. To do so could result in failure of the equipment.

Do not divert your attention from the operation. Stay alert to the possibility of accidents, and try to prevent them from happening.

Do not jerk or swing the load. Avoid shock loads by starting and stopping the load smoothly. Shock loads overload the equipment and may cause damage.

Do not leave a suspended load unattended. Place the load on the ground before leaving it unattended.

- 2.3.1 MOVE THE LOAD slowly and smoothly, only a small distance at first. Make sure the load is balanced and securely attached before continuing.
- 2.3.2 DISENGAGE THE RATCHET on the hand winch, and keep it disengaged throughout the operation. If the ratchet is engaged, you will be unable to lower the load.
- 2.3.3 TURN THE DISC BRAKE HANDLE to operate the winch. See figure 5.
 - a TURN THE HANDLE CLOCKWISE to wind wire rope onto the drum and RAISE the load. If wire rope unwinds from the drum when the handle is rotated clockwise, the wire rope is installed incorrectly. **Install the wire rope correctly before continuing. Refer to the Hand Winch Owner's Manual.**
 - b TURN THE HANDLE COUNTERCLOCKWISE to unwind wire rope from the winch drum and LOWER the load.
- 2.3.4 OBSERVE THE WIRE ROPE as it winds onto the drum. If it becomes loose, uneven, or overlapped, stop the operation and rewind the wire rope before continuing. **Continued operation with overlapped or uneven wire rope can damage the wire rope and shorten its life.**

3.1 Cleaning the Disc Brake

Important!

Increase the frequency of maintenance procedures if the equipment is:

- Operated for long periods.
- Used to lift heavy loads.
- Operated in wet, dirty, hot, or cold surroundings.

Clean the disc brake to remove dirt and help prevent rust and corrosion.

- 3.1.1 CLEAN THE DISC BRAKE every six months or whenever it is dirty.
- 3.1.2 WIPE THE ENTIRE BRAKE with an oily rag to remove dirt and grease.
- 3.1.3 LEAVE A LIGHT FILM of oil on all surfaces to protect them against rust and corrosion.
- 3.1.4 WIPE OFF excessive amounts of oil to avoid the accumulation of dirt.

3.2 Lubricating the Disc Brake

CAUTION

Do not over lubricate the brake bushings. Over lubricating may cause oil to leak onto the friction discs, which may damage the friction discs or result in poor operation of the disc brake.

Lubricate the brake properly to help protect it from wear and corrosion. Read the following instructions carefully.

- 3.2.1 LUBRICATE THE DISC BRAKE at least every 6 months.
- 3.2.2 PLACE 2 OR 3 DROPS of SAE 30 non-detergent oil into the hole in the brake housing marked "oil". See figure 6.
- 3.2.3 TURN THE BRAKE several times to allow the oil to penetrate, and wipe off excess oil to avoid accumulation of dirt.

Important!

- Make sure lubricant has a temperature rating appropriate for the ambient temperatures of the operation.

Figure 6 – Brake Lubrication

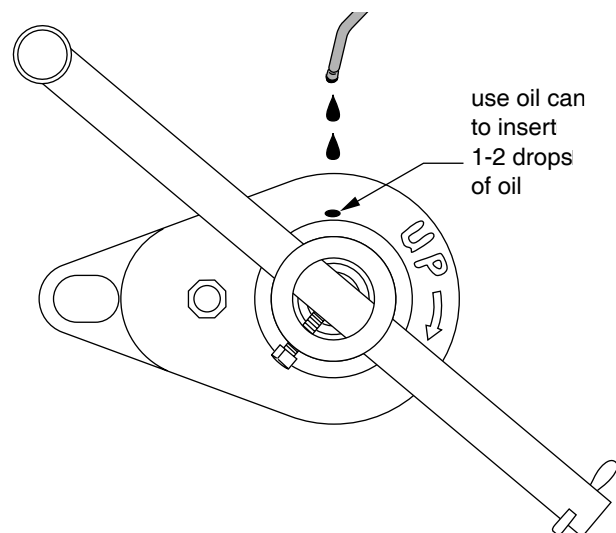

3.3 Inspecting the Equipment

▲WARNING

Do not use damaged or malfunctioning equipment. Place an “OUT OF ORDER” sign on the brake. Do not use the brake until the sign is removed by a qualified maintenance person who has completely corrected the problem.

Important!

- Start an inspection program as soon as you put the disc brake into use.
- Appoint a qualified person to be responsible for regularly inspecting the equipment.
- Keep written records of inspection. This allows comparison with comments from previous inspections so you can see changes in condition or performance.

Perform inspections:

- Before each operation.
- Every 3 hours during operation.
- Whenever you notice signs of damage or poor operation.
- Whenever you return the disc brake to service from storage.
- Whenever you have, or think you may have, overloaded or shock loaded the equipment.

Inspect the disc brake to detect signs of damage or poor operation before they become hazardous.

3.3.1 REFER TO THE HAND WINCH OWNER'S MANUAL for information regarding winch inspection. This Disc Brake Owner's Manual does not include instructions for inspecting the winch.

3.3.2 VISUALLY INSPECT the entire disc brake.

- Check all equipment for cracks, dents, bending, rust, wear, corrosion and other damage.
- Make sure the brake is attached securely to the winch.
- Make sure the brake is properly lubricated.
- Make sure all labels are firmly attached, legible, free of damage and clean.

3.3.3 TEST BRAKE PERFORMANCE by operating the brake with a 100 pound load attached to the winch.

- Listen for unusual noises, and look for signs of damage as you operate the brake.
- Make sure the brake rotates smoothly in both directions.
- Make sure the disc brake ratchet pawl clicks firmly as the brake handle is turned clockwise.
- Check for excessive movement indicating worn or loose parts. If necessary, disassemble the brake and inspect the drive assembly. Check for wear, dirt buildup, corrosion, cracks, and other damage.
- Check for worn friction discs. Raise the load, then lower it and stop it a few feet off the ground. If the load continues to coast or creep, the friction discs may be worn and in need of replacement.

Completely correct all problems before continuing. Use the Troubleshooting Chart to help determine the cause of certain problems. See table 2.

3.4 Repairing the Disc Brake

Important!

- It is your responsibility to determine when to replace parts. When considering whether to continue using a part or to replace it, remember that replacing it is the best way to avoid further equipment damage.
- Appoint a qualified person to be responsible for all repairs to the equipment.

- 3.4.1 GET FACTORY AUTHORIZATION for all repairs. Unauthorized repairs will void the warranty, and may lead to damage or failure of the disc brake.
- 3.4.2 REPLACE DAMAGED OR POORLY OPERATING PARTS with Thern repair parts.
- 3.4.3 TO ORDER REPAIR PARTS, contact your local dealer. Include the following information when ordering:
 - model number
 - **serial number** (or code number)
 - part number
 - date purchased, and from whom
 - description of what happened, or what is wrong
 - your name and return address

Table 2 – Troubleshooting Chart

problem	cause	correction
brake handle turns hard or not at all	<ul style="list-style-type: none"> • ratchet on winch engaged • load too heavy • spring pins loose or broken • brake locked with corrosion or dirt • gears or bearings broken or locked 	disengage winch ratchet lighten load inspect winch and brake, repair as necessary repair and clean as necessary inspect and repair as necessary
brake does not hold load	<ul style="list-style-type: none"> • friction discs worn or damaged • friction discs damaged from over lubrication • disc brake ratchet pawl damaged 	inspect and replace as necessary inspect and replace as necessary inspect and repair as necessary
overheating	<ul style="list-style-type: none"> • operated too long without rest • load too heavy • poor lubrication 	allow to cool lighten load inspect and lubricate as necessary
unusual noises		
high pitched squeak grinding noise	<ul style="list-style-type: none"> • poor lubrication • dirt in brake • broken gears or bearings 	lubricate brake properly inspect and clean as necessary inspect and replace as necessary
rattling noise uneven clicking noise in brake weak clicking noise in brake	<ul style="list-style-type: none"> • loose screws or other fasteners • broken gear tooth in brake • spring or ratchet pawl dirty or damaged • worn brake ratchet pawl, gear, or spring 	tighten all fasteners inspect and repair as necessary inspect and clean or repair as necessary inspect and replace as necessary
no clicking noise in brake	<ul style="list-style-type: none"> • ratchet incorrectly installed • ratchet pawl damaged or worn excessively 	disassemble and install correctly inspect and replace as necessary

3.5 Labels and Plates

Keep all labels and plates attached to the brake and legible at all times. Replacements are available from the factory.

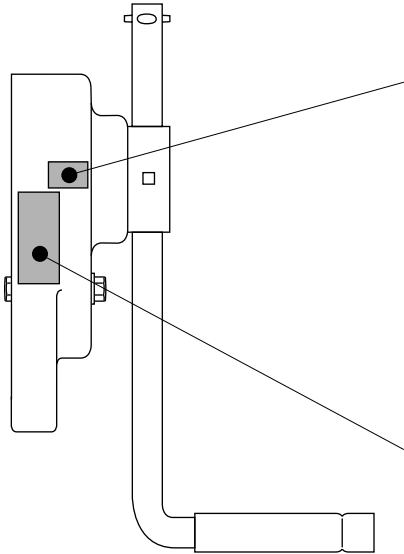

oil indication label
part no. A2176

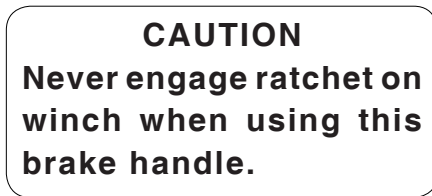

brake caution label
part no. A2221

item	description	part number	qty.	part number	qty.
1	handle assembly	B1038	1	B1038	1
2	bushing	A1104	1	A1104	1
3	ratchet pawl	A1103	1	A1103	1
4	spring	A1842	1	A1842	1
5	set screw	A3885	1	A3885	1
6	cover	A1105	1	A1105	1
7	cap screw	A3884	1	A3884	1
8	jam nut	A3330	1	A3330	1
9	lock washer	A3357	1	A3357	1
10	brake housing	C1015	1	C1015	1
11	drive assembly	B1602	1	B1221	1
12	cotter pin	A4303	2	A4303	2
13	machinery bushing	A3906	1	-	-
14	brake retainer	A1100	1	-	-
15	lock washer	A3352	1	-	-
16	cap screw	A2951	1	-	-

¹ These parts are for brakes that are factory installed on hand winch Models M4021B, M4031B, 462B, and 472B.

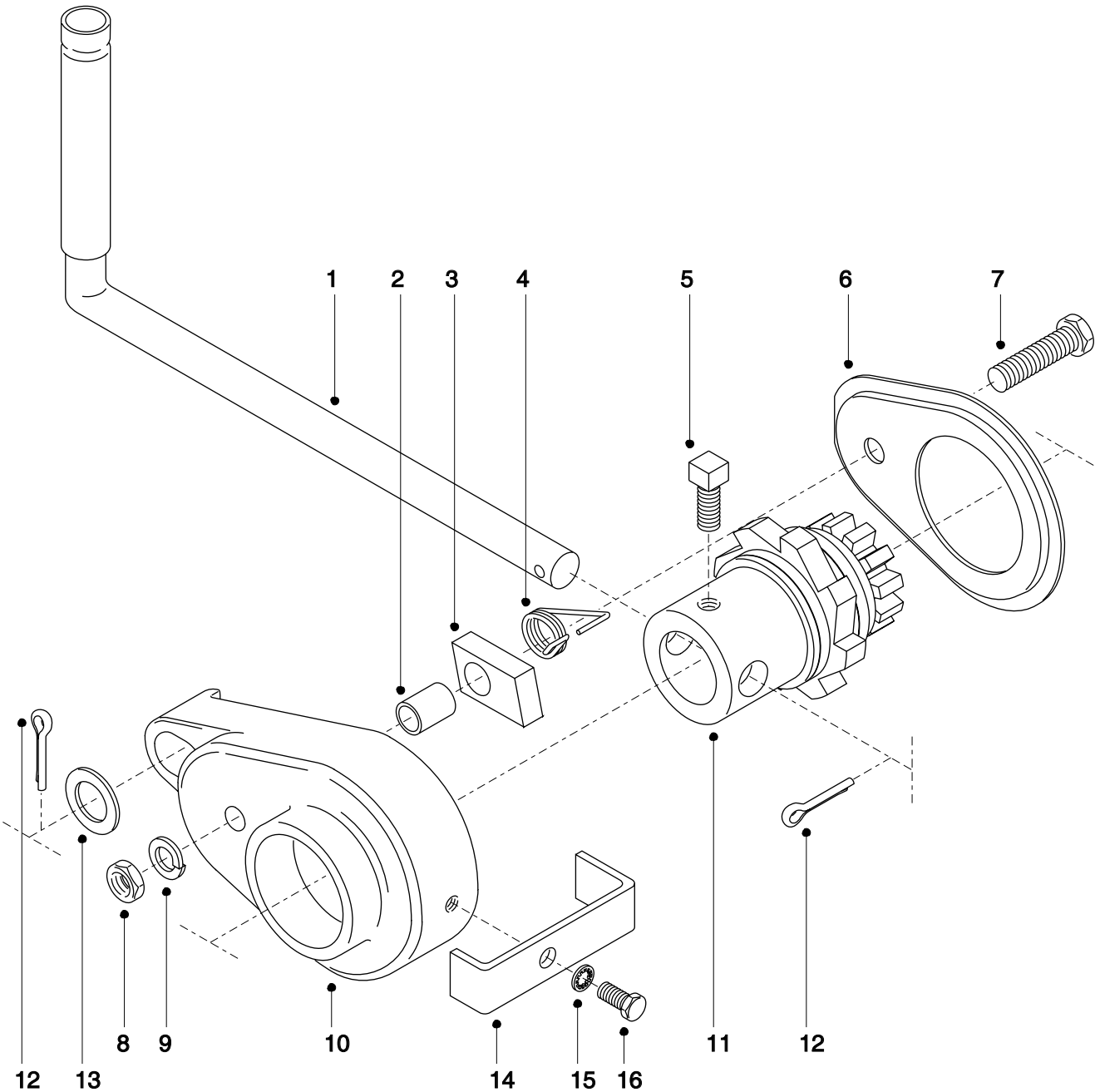

item	description	part number	part number	part number	qty.
1	handle assembly	B1015	B1015	B1015	1
2	ratchet pawl	A1047	A1047	A1047	1
3	spring	A1364	A1364	A1364	1
4	spacer	A1068	A1068	A1068	1
5	set screw	A4267	A4267	A4267	1
6	cover	B1019	B1019	B1019	1
7	cap screw	A4183	A4183	A4183	1
8	jam nut	A3330	A3330	A3330	1
9	lock washer	A3357	A3357	A3357	1
10	brake housing	C1009	C1009	C1010	1
11	drive assembly	B1020	B1209	B1603	1
12	cotter pin	A4309	A4309	A4309	1
13	lock washer	A3352	A3352	A3352	2
14	capscrew	A2951	A2951	A2951	2

¹ These parts are for brakes that are factory installed on hand winch Model 482B.

