



Read this Owner's Manual thoroughly before operating the equipment. Keep it with the equipment at all times. Replacements are available from Thern, Inc., PO Box 347, Winona, MN 55987, 507-454-2996. www.thern.com

IMPORTANT: Please record product information on page 2. This information is required when calling the factory for service.

ORIGINAL TEXT



Owner's Manual

For Thern
Spur Gear Hand Winches

Two-Year Limited Warranty

Please record the following:

Date Purchased: _____

Model No.: _____

Code No.: _____

This information is required when calling the factory for service.

Thern, Inc. warrants its products against defects in material or workmanship for two years from the date of purchase by the original using buyer, or if this date cannot be established, the date the product was sold by Thern, Inc. to the dealer. To make a claim under this warranty, contact the factory for an RGA number. The product must be returned, prepaid, directly to Thern, Inc., 5712 Industrial Park Road, Winona, Minnesota 55987. The following information must accompany the product: the RGA number, the date of purchase, the description of the claimed defect, and a complete explanation of the circumstances involved. If the product is found to be defective, it will be repaired or replaced free of charge, and Thern, Inc. will reimburse the shipping cost within the contiguous USA.

This warranty does not cover any damage due to accident, misuse, abuse, or negligence. Any alteration, repair or modification of the product outside the Thern, Inc. factory shall void this warranty. This warranty does not cover any costs for removal of our product, downtime, or any other incidental or consequential costs or damages resulting from the claimed defects. This warranty does not cover brake discs, wire rope or other wear components, as their life is subject to use conditions which vary between applications.

FACTORY AUTHORIZED REPAIR OR REPLACEMENT AS PROVIDED UNDER THIS WARRANTY IS THE EXCLUSIVE REMEDY TO THE CONSUMER. THERN, INC. SHALL NOT BE LIABLE FOR ANY INCIDENTAL OR CONSEQUENTIAL DAMAGES FOR BREACH OF ANY EXPRESS OR IMPLIED WARRANTY ON THIS PRODUCT. EXCEPT TO THE EXTENT PROHIBITED BY APPLICABLE LAW, ANY IMPLIED WARRANTY OF MERCHANTABILITY OR FITNESS FOR A PARTICULAR PURPOSE ON THIS PRODUCT IS LIMITED IN DURATION TO THE DURATION OF THIS WARRANTY.

Some states do not allow the exclusion or limitation of incidental or consequential damages, or allow limitations on how long an implied warranty lasts, so the above limitation or exclusion may not apply to you. This warranty gives you specific legal rights, and you may also have other rights which vary from state to state.

Note: Thern, Inc. reserves the right to change the design or discontinue the production of any product without prior notice.

About This Manual

The Occupational Safety and Health Act of 1970 states that it is the employer's responsibility to provide a workplace free of hazard. To this end, all equipment should be installed, operated, and maintained in compliance with applicable trade, industrial, federal, state, and local regulations. It is the equipment owner's responsibility to obtain copies of these regulations and to determine the suitability of the equipment to its intended use.

This Owner's Manual, and warning labels attached to the equipment, are to serve as guidelines for hazard-free installation, operation, and maintenance. They should not be understood to prepare you for every possible situation.

The information contained in this manual is applicable only to the Thern Spur Gear Hand Winches. Do not use this manual as a source of information for any other equipment.

The following symbols are used for emphasis throughout this manual:

⚠WARNING

Failure to follow 'WARNING!' instructions may result in equipment damage, property damage, and/or serious personal injury.

⚠CAUTION

Failure to follow 'CAUTION!' instructions may result in equipment damage, property damage, and/or minor personal injury.

Important!

Failure to follow 'important!' instructions may result in poor performance of the equipment.

Suggestions for Safe Operation

⚠WARNING

DO the following:

Read and comply with the guidelines set forth in this Owner's Manual. Keep this manual, and all labels attached to the winch, readable and with the equipment at all times. Contact Thern, Inc. for replacements.

Check lubrication before use.

Install the wire rope securely to the winch drum.

Keep at least 4 wraps of wire rope wound on the drum at all times, to serve as anchor wraps. With less than 4 wraps on the drum the wire rope could come loose, causing the load to escape.

Keep hands away from the drum, gears, wire rope, and other moving parts of the equipment.

Keep all unnecessary personnel away from winch while in operation. Keep out of the path of the load, and out of the path of a broken wire rope that might snap back and cause injury.

DO NOT do the following:

Do not lift people, or things over people. Do not walk or work under a load or in the line of force of any load.

Do not exceed the load rating of the winch or any other component in the system. To do so could result in failure of the equipment.

Do not use more than one winch to move a load that unless each winch was designed for use in a multiple winch system.

Do not operate with other than manual power.

Do not use damaged or malfunctioning equipment. To do so could result in failure of the equipment.

Do not modify the equipment in any way. To do so could cause equipment failure.

Do not wrap the wire rope around the load. This damages the wire rope and could cause the load to escape. Use approved rigging connectors to secure the wire rope to the load.

Do not operate the winch with guards removed or improperly installed.

Do not divert your attention from the operation. Stay alert to the possibility of accidents, and try to prevent them from happening.

Do not jerk or swing the load. Avoid shock loads by starting and stopping the load smoothly. Shock loads overload the equipment and may cause damage.

Do not lift loads or pull loads on an incline unless the winch is equipped with a brake.

Do not leave a suspended load unattended unless specific precautions have been taken to secure the load and keep people away from the winch and out from under the load.



1.1 Installing the Winch

Important!

- Inspect the winch immediately following installation according to the Instructions for Periodic Inspection. This will give you a record of the condition of the winch with which to compare future inspections.
- A qualified professional should inspect or design the foundation to insure that it will provide adequate support.
- Locate the winch so it will be visible during the entire operation.
- Do not weld the winch frame to the foundation or support structure. Welding the frame may void warranty, contact Thern, Inc. Use fasteners as instructed.

⚠WARNING

Do not install the winch in an area defined as hazardous by the National Electric Code, unless installation in such an area has been thoroughly approved.

Do not install the winch near corrosive chemicals, flammable materials, explosives, or other elements that may damage the winch or injure the operator. Adequately protect the winch and the operator from such elements.

Position the winch so the operator can stand clear of the load, and out of the path of a broken wire rope that could snap back and cause injury.

Attach the winch to a rigid and level foundation that will support the winch and its load under all load conditions, including shock loading.

Install the wire rope securely to the winch drum. A poorly secured wire rope could come loose from its anchor and could release the load. See Figure 3.

- 1.1.1 CONSULT APPLICABLE CODES AND REGULATIONS for specific rules on installing the equipment.
- 1.1.2 LOCATE THE WINCH in an area clear of traffic and obstacles that could interfere with operation. Make sure winch is accessible for maintenance and operation.
- 1.1.3 MAINTAIN A FLEET ANGLE between 1/2 and 1-1/2 degrees. The proper fleet angle minimizes wire rope damage by helping the wire rope wind uniformly onto the drum. See Figure 1.
- 1.1.4 FASTEN THE WINCH securely to the foundation.
 - a FOR STANDARD PRODUCTS referred to in this manual, use 3/8 inch coarse thread fasteners, grade 5 or better. Torque for grade 5 fasteners without lubrication is 30 ft. lb. Make sure mounting holes are secured to a solid foundation able to support the winch and the load under all conditions with design factors based on accepted engineering practices.
 - b NON-STANDARD PRODUCTS that vary from the original design may have different fastening requirements. Contact a structural engineer or Thern, Inc. for this information.

TO COMPLY WITH LOCAL CODES, CONTACT A QUALIFIED PROFESSIONAL TO OBTAIN PROPER STRUCTURE OR FOUNDATION SPECIFICATIONS FOR THE MOUNTING OF THERN PRODUCTS.

Important!

- Use a sheave or roller guide to direct the wire rope to the drum whenever possible.
- Install sheaves, tracks and other equipment so they will remain fixed under all load conditions. Follow the recommendations of the equipment manufacturer.
- Use sheaves of proper diameter to minimize wear on the wire rope. Follow the recommendations of the sheave manufacturer.

Figure 1 – Maintaining the Fleet Angle

When wire rope travels over a sheave or through a roller guide – maintain fleet angle by locating the sheave or guide an appropriate distance from the drum, shown as distance "A".

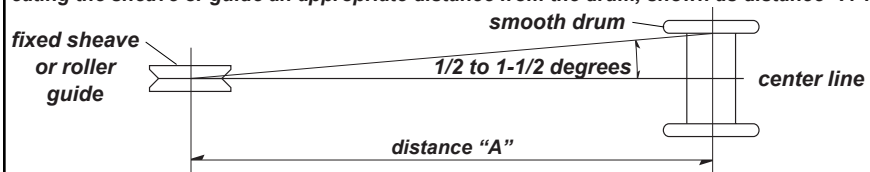

When wire rope travels directly to the load – maintain fleet angle by controlling side-to-side movement of the load with tracks or guide rails. Allowing the load to move too far to one side causes stress on the drum flange which may cause damage.

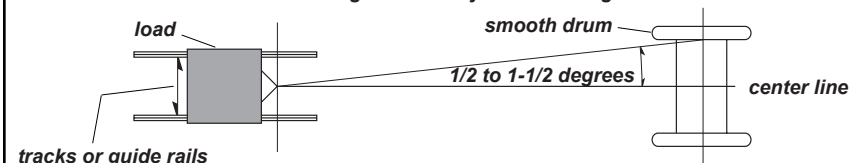

1.2 Installing the Handle

- 1.2.1 FOR MODELS M4022PB, M4032PB, M4042PBSS, M4312PB, M4312PBSS, and M4412PB equipped with PB Brakes, install the handle as follows:
- a LOOSEN THE THUMBSCREW and slide the handle toward the medallion as shown. See Figure 2A.
 - b LINE UP THE NOTCH in the handle with the point of the hex in the medallion. See Figure 2B.
 - c SLIDE THE HANDLE AND MEDALLION ASSEMBLY onto the hex drive on the brake until the flat of the handle lines up with the groove in hex drive. See Figure 2C.
 - d SLIDE THE HANDLE outward away from the medallion to the desired length and tighten the thumbscrew. See Figure 2D.
- 1.2.2 FOR MODELS M4022 AND M4032, place the handle assembly on the handle shaft and secure in place with the lock washer and hex nut.
- 1.2.3 FOR MODELS M4312 AND M4412, place the handle assembly on the drum shaft and install the hair pin cotter in the end of the drum shaft to hold the handle in place.

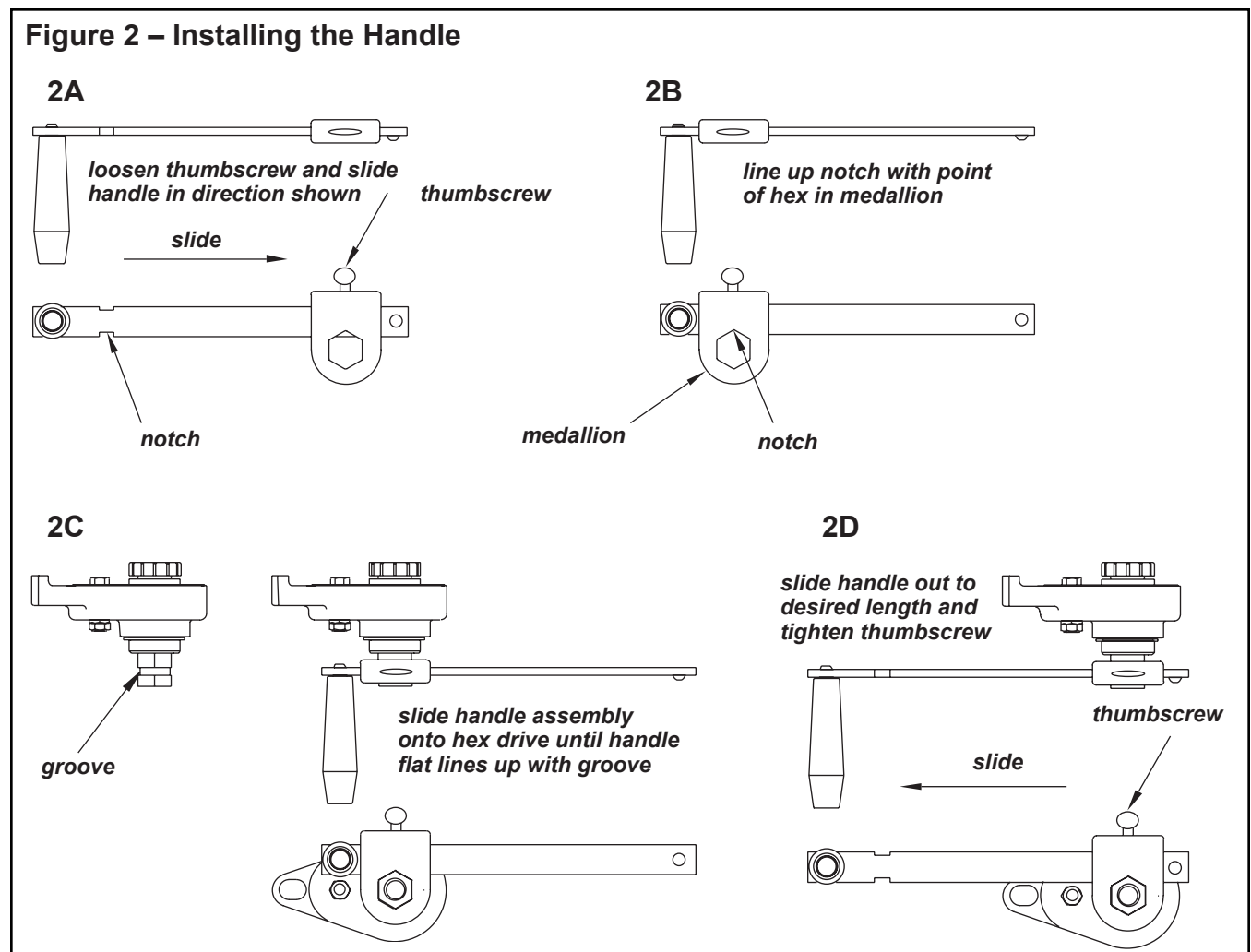

1.3 Installing the Wire Rope

Important!

- Use wire rope and other rigging equipment rated for the size of the largest load you will be moving.
- Do not drag the wire rope through dirt or debris that could cause damage, or poor operation.
- Always wear protective clothing when handling wire rope.

Figure 3A – Flange Clip Anchor

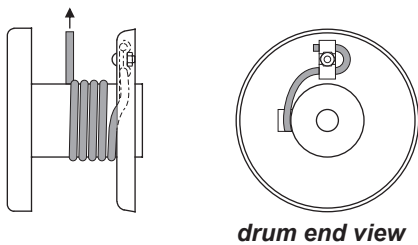

drum end view

typical installation shown
right lay – underwound*

*M4042PBSS is overwound

Wire rope assemblies can be
purchased from Thern, Inc.

Figure 3B – Quick Disconnect Anchor

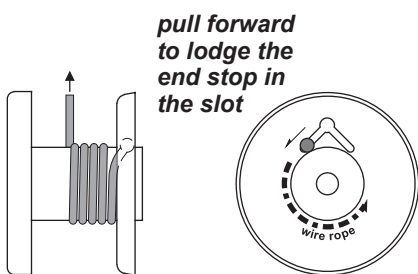

drum end view

typical installation shown
right lay – underwound*

*M4042PBSS is overwound

Wire rope assemblies can be
purchased from Thern, Inc.

⚠WARNING

Install the wire rope so it is wound correctly as shown, or the winch will not work properly, and could release the load.

Install the wire rope securely to the winch drum. A poorly secured wire rope could come loose from its anchor and could release the load.

- 1.3.1 PURCHASE THE PROPER WIRE ROPE for your application. Keep the following in mind when selecting a wire rope. Contact a reputable wire rope supplier for help.
 - a BREAKING STRENGTH of new wire rope should be at least 3 times greater than the largest load placed on the winch. If loads are lifted or pulled on an incline, the breaking strength must be at least 5 times greater than the largest load. These are minimum values and will vary with the type of load and how you are moving it.
 - b WIRE ROPE LAY must agree with the winding direction of the drum to help insure proper winding.
 - c WE RECOMMEND 7 x 19 galvanized aircraft cable for diameters up to 5/16 inch.
- 1.3.2 ANCHOR THE WIRE ROPE to the drum using either the flange clip or quick disconnect anchor.
 - a FLANGE CLIP ANCHOR. See Figure 3A.
 - PASS THE END OF THE WIRE ROPE through the hole in the flange.
 - INSERT THE CARRIAGE BOLT, loop the wire rope around the bolt, and install the clip so the wire rope is held by the curves of the clip.
 - INSTALL THE JAM NUT and tighten it until the wire rope is flattened against the drum flange.
 - b QUICK DISCONNECT ANCHOR. See Figure 3B.
 - PUSH THE END STOP through the large center hole in the drum flange.
 - PULL THE WIRE ROPE forward to lodge the end stop in the slot.
- 1.3.3 TURN THE HANDLE CLOCKWISE to wind wire rope onto the drum. If wire rope unwinds from the drum when the handle is rotated clockwise, the wire rope is installed incorrectly. **Install the wire rope correctly before continuing.**
- 1.3.4 WIND FOUR FULL WRAPS of wire rope onto the drum by operating the winch while holding the wire rope taught. **These wraps serve as anchor wraps and must remain on the drum at all times.**

2.1 General Theory of Operation

Important!

- Limit nonuniform winding by keeping tension on the wire rope and by maintaining the proper fleet angle.
- It is your responsibility to detect and account for different factors affecting the condition and performance of the equipment.

- 2.1.1 THE PULL REQUIRED to move the load must not exceed the load rating of the winch. Consider the total force required to move the load, not the weight of the load.
- 2.1.2 THIS EQUIPMENT CAN develop forces that will exceed the load rating. It is the responsibility of the equipment user to limit the size of the load. Inspect the equipment regularly for damage according to the instructions contained in this manual.
- 2.1.3 USE A DISC BRAKE on all hand winches used to lift loads or pull loads on an incline.
- 2.1.4 PERFORMANCE RATINGS of the equipment are affected by the amount of wire rope wound on the drum, the way in which it is wound, and the way the winch is used.
- a DRUM CAPACITY depends on how tightly and evenly the wire rope is wound on the drum. Actual drum capacities are usually 25-30% less than values shown in performance Tables, due to loose winding and overlapping.
 - b FORCE REQUIRED TO LIFT the load increases with each additional layer of wire rope wound onto the drum. The value shown in performance Tables is based on an empty drum and maximum handle length.
 - c LOAD RATING represents the maximum pull that can be placed on new equipment. Load ratings are assigned values for specific amounts of load travel or wire rope accumulation. The load rating decreases as layers of wire rope accumulate on the drum.
- 2.1.5 DUTY RATINGS refer to the type of use the equipment is subject to. Consider the following when determining duty rating.
- a ENVIRONMENT: harsh environments include hot, cold, dirty, wet, corrosive, or explosive surroundings. **Protect the equipment from harsh environments when possible.**
 - b MAINTENANCE: poor maintenance, meaning poor cleaning, lubrication, or inspection, leads to poor operation and possible damage of the equipment. **Minimize poor maintenance by carefully following the instructions contained in this manual.**
 - c LOADING: severe loading includes shock loading and moving loads that exceed the load rating of the equipment. **Avoid shock loads, and do not exceed the load rating of the equipment.**
 - d FREQUENCY OF OPERATION: frequent or lengthy operations increase wear and shorten the life span of gears, bearings, and other components. **Increase maintenance of the equipment if used in frequent operations.**
- 2.1.6 AIRBORNE NOISE EMISSIONS vary depending on load and the type of winch being used. Standard configurations do not typically exceed a sound pressure level of 80dB(A) at workstations.

CONTACT THE FACTORY FOR MORE INFORMATION.

2.2 Breaking-In the Winch

- 2.2.1 BREAK-IN OCCURS during the first 10 hours of normal operation. During break-in, mating surfaces become polished, and clearances increase. This is desired for efficient operation of bearings and gears.
- 2.2.2 INSPECT THE WINCH following break-in according to the Instructions for Periodic Inspection.

2.3 Preparing for Operation

- 2.3.1 CONSIDER THE OPERATION. Do not begin until you are sure you can perform the entire operation without hazard.
- 2.3.2 INSPECT ALL COMPONENTS of the system.
- a INSPECT THE WINCH and other equipment according to the Instructions for Frequent Inspection.
 - b OPERATORS must be in good health, alert, thoroughly trained in operating the equipment, and properly clothed (hard hat, safety shoes and safety glasses, no loose clothing).
 - c THE LOAD must be clear of other objects and free to move. Make sure the load will not tip, spin, roll away, or in any way move uncontrollably.
- 2.3.3 KNOW YOUR LOAD and make sure you do not exceed the load rating of the winch or any other equipment in the system.

Important!

- When determining whether the load will exceed the load rating, consider the total force required to move the load.

Figure 4 – Attaching Load

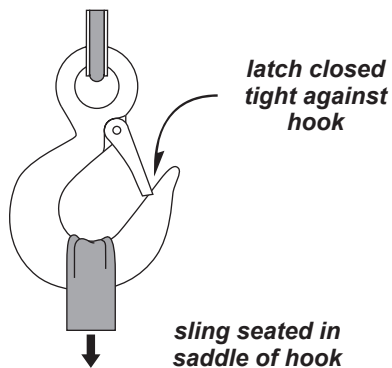

2.4 Attaching the Load

⚠WARNING

Do not wrap the wire rope around the load. This damages the wire rope and could cause the load to escape. Use a sling or other approved lifting device.

- 2.4.1 CLEAR OBJECTS from the path of the load so you can move it freely and observe it at all times during the operation.
- 2.4.2 ATTACH THE LOAD using a nylon sling, or other approved lifting device. Follow the recommendations of the sling manufacturer.
- a SEAT THE SLING in the saddle of the hook with the hook latch completely closed. See Figure 4.
 - b CENTER THE LOAD on the hook so it will remain balanced and not tip or rotate to one side.

2.5 Moving the Load

- 2.5.1 MOVE THE LOAD slowly and smoothly, only a small distance at first. Make sure the load is balanced and securely attached before continuing.
- 2.5.2 TURN THE HANDLE CLOCKWISE to wind wire rope onto the drum. If wire rope unwinds from the drum when the handle is rotated clockwise, the wire rope is installed incorrectly. **Install the wire rope correctly before continuing.**
- 2.5.3 OBSERVE THE WIRE ROPE as it winds onto the drum. If it becomes loose, uneven, or overlapped, stop the operation and rewind the wire rope before continuing. **Continued operation with overlapped or uneven wire rope can damage the wire rope and shorten its life.**
- 2.5.4 FOR MODELS M4312 AND M4412 ONLY. Move the handle to the countershaft to quickly wind or unwind UNLOADED wire rope. **Do not attempt to move a load with the handle installed on the countershaft.**
- 2.5.5 FOR MODELS M4022, M4032, M4312 AND M4412 ONLY. Engage the ratchet when winding wire rope onto the drum, disengage the ratchet to unwind the wire rope. **DO NOT ENGAGE THE RATCHET while the winch gears are turning.** Stop the winch before engaging the ratchet. Disengage the ratchet by moving the load slightly to remove pressure from the ratchet, then pull out and turn the ratchet knob 90 degrees. Grip the handle tightly at all times during operation. If you release the handle the load may backdrive causing the handle to spin. **Do not try to stop a spinning handle, step clear until the spinning stops.**
- 2.5.6 MOVE THE LOAD slowly and smoothly, only a small distance at first. Make sure the load is balanced and securely attached before continuing.
- 2.5.7 OBSERVE THE WIRE ROPE as it winds onto the drum. If it becomes loose, uneven, or overlapped, stop the operation and rewind the wire rope before continuing. Continued operation with overlapped or uneven wire rope can damage the wire rope and shorten its life.

Important!

- Obey a stop signal from anyone.
- Maintain tension on the wire rope to keep it tightly and evenly wound on the drum.
- If the winch and load are not visible during the entire operation, get help from another person.
- Appoint a supervisor if more than one person is involved in the operation. This will reduce confusion and increase safety.
- When lifting a load, use a tag line to keep the load from swinging or twisting, while keeping yourself away from the load.
- Remove the winch handle when the winch is not in use, to help avoid unauthorized use.

3.1 Cleaning the Winch

Clean the winch to remove dirt and help prevent rust and corrosion.

- 3.1.1 CLEAN THE WINCH every six months or whenever it is dirty.
- a WIPE ALL EQUIPMENT to remove dirt and grease.
 - b LEAVE A LIGHT FILM of oil on all surfaces to protect them against rust and corrosion.
 - c WIPE OFF excessive amounts of oil to avoid the accumulation of dirt.
- 3.1.2 REMOVE ALL UNNECESSARY OBJECTS from the area surrounding the winch.

3.2 Lubricating the Winch

Important!

Increase the frequency of maintenance procedures if the winch is:

- Operated for long periods.
- Used to pull heavy loads.
- Operated in wet, dirty, hot, or cold surroundings.

Important!

- Make sure lubricant has a temperature rating appropriate for the ambient temperatures of the operation.

⚠ CAUTION

Do not over lubricate the brake bushings on models equipped with a brake. Over lubricating may cause oil to leak onto the friction discs, which may damage the friction discs or result in poor operation of the disc brake.

Lubricate the spur gears before each operation, and periodically during operation. Failure to lubricate the gears will cause damage or deformation of gear teeth.

Lubricate the winch properly to help protect it from wear and rust. Read the following instructions carefully.

- 3.2.1 CONSULT MANUFACTURER'S RECOMMENDATIONS for specific information on lubricating the wire rope and other equipment.
- 3.2.2 LUBRICATE WINCH BEARINGS AND SHAFTS at least every 6 months.
- a APPLY 2 TO 3 DROPS of SAE 30 non-detergent oil to bearings and shafts at all friction points.
 - b ROTATE THE DRUM several times to allow the oil to penetrate, and wipe off excess oil to avoid accumulation of dirt.
- 3.2.3 LUBRICATE WINCH GEARS before every operation and at least every 10 hours during operation.
- a APPLY A LIGHT FILM of open gear lubricant to the gear teeth on all gears.
 - b USE SPRAYON S00201 or equivalent open gear lube. For dirty conditions use a dry lubricant such as dry graphite or Moly.
 - c If equipped with a guard mounted grease fitting(s) use standard grease gun to apply grease onto gears and rotate handle to distribute until gears are evenly coated.
- 3.2.4 LUBRICATE THE DISC BRAKE IF APPLICABLE at least every 6 months. Place 1 or 2 drops of SAE 30 non-detergent oil into the hole in the brake housing marked "oil", and turn the brake several times to allow the oil to penetrate.
- 3.2.5 LUBRICATE THE WIRE ROPE and other equipment by following the manufacturer's recommendations.

3.3 Inspecting the Equipment

Important!

- Start an inspection program as soon as you put the winch into use.
- Appoint a qualified person to be responsible for regularly inspecting the equipment.
- Keep written records of inspection. This allows comparison with comments from previous inspections so you can see changes in condition or performance.

Perform frequent inspections:

- Before each operation.
- Every 3 hours during operation.
- Whenever you notice signs of damage or poor operation.

Frequent Wire Rope Inspection:

- Use ASME B30.7 as a guideline for rope inspection, replacement and maintenance.
- Check the wire rope, end connections and end fittings for corrosion kinking, bending, crushing, bird-caging or other signs of damage.
- Check the number, distribution and type of visible broken wires. See paragraph 3.3.4 b and Figure 5.
- Check the wire rope for reduction of rope diameter from loss of core support, or wear of outside wires. See Figure 7.
- Take extra care when inspecting sections of rapid deterioration such as sections in contact with saddles, sheaves, repetitive pickup points, crossover points and end connections.

⚠WARNING

Do not use damaged or malfunctioning equipment. Place an “OUT OF ORDER” sign on the winch. Do not use the winch until the sign is removed by a qualified maintenance person who has completely corrected the problem.

Inspect the winch to detect signs of damage or poor operation before they become hazardous.

3.3.1 CONSULT APPLICABLE CODES AND REGULATIONS for specific rules on inspecting the winch and other equipment.

3.3.2 CONSULT MANUFACTURER’S RECOMMENDATIONS for information on inspecting the wire rope and other equipment.

3.3.3 Instructions for Frequent Inspection

- a VISUALLY INSPECT the entire winch and all other equipment involved in the operation.
 - Check all equipment for cracks, dents, bending, rust, wear, corrosion and other damage.
 - Make sure the wire rope is installed correctly and anchored securely to the drum.
 - Make sure the winch and brake are properly lubricated.
 - Make sure fasteners are installed to securely hold the handle in place.
 - Make sure mounting fasteners are tightened securely.
 - Make sure the foundation is in good condition, and capable of supporting the winch and its load under all load conditions.
- b TEST WINCH PERFORMANCE by operating the winch with a load not exceeding the load rating.
 - Listen for unusual noises, and look for signs of damage as you operate the winch.
 - Make sure the wire rope winds evenly and tightly onto the drum. If it is loose or uneven, rewind it before continuing.
 - Make sure the handle rotates freely in both directions.
 - Make sure the load moves smoothly without hesitation or strain.
 - On models equipped with a ratchet, make sure the ratchet engages and disengages completely.
 - On models equipped with a brake, make sure the disc brake ratchet pawl clicks firmly as the brake handle is turned clockwise.
 - On models equipped with a brake, check the brake. Raise the load, then lower it and stop it a few feet off the ground. If the load continues to coast or creep under normal operating conditions, the friction discs may be worn and in need of replacement. Contact the factory.

Completely correct all problems before continuing. Use the Troubleshooting Chart to help determine the cause of certain problems. See Table 2.

Perform periodic inspections:

- Every 6 months.
- Whenever you return the winch to service from storage.
- Whenever you notice damage or poor operation in a frequent inspection.
- Whenever you have, or think you may have, overloaded or shock loaded the winch.

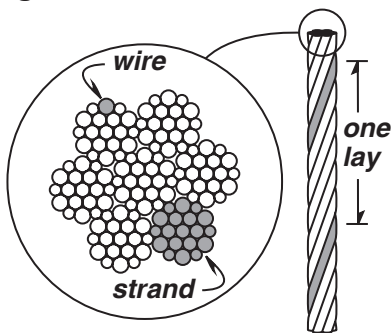
Figure 5 – Broken Wires

Wire rope assembly must be replaced if more than 6 wires are broken in one lay, or if more than 3 wires are broken in one strand in one lay.

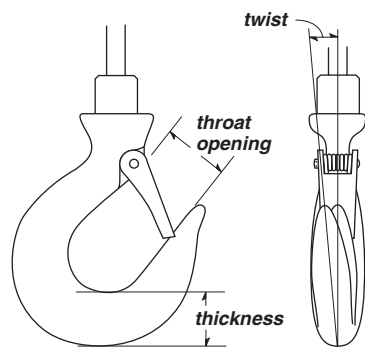
Figure 6 – Load Hook Inspection

The wire rope assembly must be replaced if the throat opening is 15% wider than nominal, if the thickness is 10% less than nominal, or if the hook is twisted 10° or more.

3.3.4 Instructions for Periodic Inspection, see Table 1.

- a VISUALLY INSPECT the winch and all other equipment.
 - Disassembly may be required in order to properly inspect individual components. Contact factory for assembly/disassembly instructions. Disassembly of the winch or brake before contacting Thern, Inc. voids all warranties.
 - Check the finish for wear, flaking, or other damage.
 - Check all equipment, including wire rope for cracks, dents, bending, rust, wear, corrosion and other damage. If the winch was overloaded, or if you notice cracks and other signs of overloading and damage promptly remove equipment from use and have it repaired or replaced. **DO NOT CONTINUE TO USE DAMAGED OR OVERLOADED EQUIPMENT OR WIRE ROPE.**
 - Check all fasteners for stripped threads, wear, bending, and other damage.
 - Check the foundation for cracks, corrosion, and other damage.
 - Make sure the winch and brake are properly lubricated.
 - Make sure all labels and plates are readable, firmly attached, free of damage and clean. Replacements are available from the factory.
- b REMOVE THE WIRE ROPE entirely from the drum.
 - Always wear protective clothing when handling wire rope.
 - Check the entire length of wire rope for bent wires, crushed areas, broken or cut wires, corrosion, and other damage. Carefully inspect areas that pass over sheaves or through roller guides.
 - Note the location and concentration of broken wires. Replace wire rope if more than 6 wires are broken in one lay, or more than 3 wires are broken in one strand in one lay. See Figure 5.
 - Make sure the load hook or other device is securely attached to the wire rope, and the wire rope where it is attached is not frayed, corroded, broken, or otherwise damaged.
 - Measure the throat opening, thickness, and twist of the hook. Replace the hook if it shows signs of damage. See Figure 6.
 - Make sure hook latch opens without binding and closes when released.
 - Check the anchor holes in the drum flange for signs of wear or distortion.
- c PLACE enough weight to keep the wire rope straight and tightly drawn.
 - Measure the diameter of the wire rope, especially in areas where wear is noticeable. Replace the wire rope if the diameter measures below the minimum diameter at any point. See Figure 7.
- d REMOVE THE WINCH from the foundation.
 - Check fasteners for stripped threads, wear, bends, and other damage.
 - Check the frame for bending, distortion, cracks and other damage. A bent frame is caused by overloading, and is a sign that your application may require a winch with a larger load rating.
- e MOVE THE DRUM with your hands.
 - Check for excessive movement indicating worn or loose gears, bearings, or shafts.

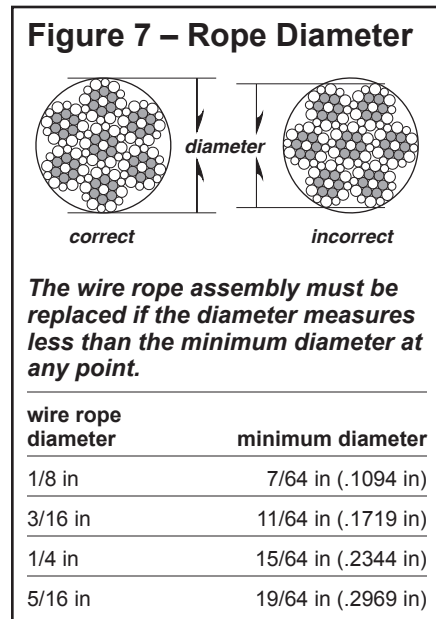

- f FASTEN THE WINCH securely to the foundation.
- g INSTALL THE WIRE ROPE.
- h TEST WINCH PERFORMANCE by operating the winch with a load equal to the load rating.
 - Listen for unusual noises, and look for signs of damage as you operate the winch.
 - Make sure the wire rope winds evenly and tightly onto the drum. If it is loose or uneven, rewind it before continuing.
 - Observe the rotating drum, look for signs of loose or misaligned bearings.
 - Make sure the handle rotates freely in both directions.
 - Make sure the load moves smoothly without hesitation or strain.
 - On models equipped with a ratchet, make sure the ratchet engages and disengages completely.
 - On models equipped with a brake, make sure the disc brake ratchet pawl clicks firmly as the brake handle is turned clockwise.
 - On models equipped with a brake, check the brake. Raise the load, then lower it and stop it a few feet off the ground. If the load continues to coast or creep under normal operating conditions, the friction discs may be worn and in need of replacement. Contact the factory.

Completely correct all problems before continuing. Use the troubleshooting chart to help determine the cause of certain problems. See Table 2.

Table 1 – Inspection Checklist		<i>checked boxes indicate damage or problem in need of repair</i>
	damages	problems
general	<input type="checkbox"/> finish weathered, flaking, otherwise damaged <input type="checkbox"/> parts cracked, bent, rusted, worn, otherwise damaged	<input type="checkbox"/> winch jerks or hesitates during operation <input type="checkbox"/> unusual noises, other signs of malfunction
fasteners	<input type="checkbox"/> stripped threads, bent, worn, otherwise damaged	<input type="checkbox"/> loose, not tightened to proper torque
gears	<input type="checkbox"/> excessively worn, cracked, corroded, otherwise damaged	<input type="checkbox"/> loose or improperly lubricated
ratchet	<input type="checkbox"/> ratchet corroded, cracked, worn, otherwise damaged	<input type="checkbox"/> ratchet does not engage or disengage
brake assembly	<input type="checkbox"/> brake corroded, cracked, worn, otherwise damaged	<input type="checkbox"/> brake does not operate properly
drum	<input type="checkbox"/> anchor hole worn, distorted, otherwise damaged	<input type="checkbox"/> excessive movement or backlash
wire rope	<input type="checkbox"/> bent, crushed, otherwise damaged <input type="checkbox"/> broken wires, see Figure 5 replace if more than 6 wires in one lay, or 3 wires in one strand in one lay, are broken <input type="checkbox"/> diameter reduced, see Figure 7 replace if diameter is excessively worn	<input type="checkbox"/> wire rope loosely or unevenly wound number per strand = number per lay = diameter =
end connections	<input type="checkbox"/> corroded, rusted, worn, otherwise damaged	<input type="checkbox"/> not securely attached
load hook	<input type="checkbox"/> twisted, bent, worn, otherwise damaged, see Figure 6 replace if twist is 10 degrees or more replace if throat width is 15% larger than nominal replace if thickness is 10% less than nominal	<input type="checkbox"/> hook latch fails to close when released twist = throat width = thickness =
labels and plates	<input type="checkbox"/> dirty, illegible, otherwise damaged	<input type="checkbox"/> loosely attached or missing
comments:		
authorized signature: _____		date _____

3.4 Repairing the Winch

Important!

- It is your responsibility to determine when to replace parts. When considering whether to continue using a part or to replace it, remember that replacing it is the best way to avoid further equipment damage.
- Replace all spring pins and retaining rings when you disassemble the winch or brake for repair or replacement.
- Appoint a qualified person to be responsible for all repairs to the equipment.

- 3.4.1 GET FACTORY AUTHORIZATION for all repairs. Unauthorized repairs will void the warranty, and may lead to damage or failure of the winch.
- 3.4.2 REPLACE DAMAGED OR POORLY OPERATING PARTS with Thern repair parts.
- 3.4.3 REFINISH AREAS where the paint is worn or flaking. A good finish helps to protect against corrosion and weather damage.
- REMOVE THE FINISH from damaged areas, down to the bare metal.
 - CLEAN THE AREA thoroughly.
 - REPAINT with a high quality primer and finishing coat.
- 3.4.4 TO ORDER REPAIR PARTS, contact your local dealer. Include the following information when ordering:
- model number
 - serial number (or code number)
 - part number
 - date purchased, and from whom
 - description of what happened, or what is wrong
 - your name and return address

4.1 Transporting the Winch

Important!

- Keep a record of what you ship, and when you send it.

- 4.1.1 PACK THE WINCH using the original packaging materials, if possible.
- 4.1.2 SEAL THE WINCH in plastic with a desiccant to help protect it from rust, corrosion, and other damage.
- 4.1.3 INSPECT THE WINCH according to the Instructions for Periodic Inspection before installing it in a new location.

4.2 Storing the Winch

- 4.2.1 SEAL THE WINCH in plastic with a desiccant to help protect it from rust, corrosion, and other damage.
- 4.2.2 STORE THE WINCH in a cool clean place away from corrosive chemicals and moisture.
- 4.2.3 ROTATE THE DRUM periodically to keep bearing and gear surfaces from becoming lacquered.
- 4.2.4 INSPECT THE WINCH according to the Instructions for Periodic Inspection before installing it for operation.

Table 2 – Troubleshooting Chart

Contact the factory for detailed instructions if you are required to disassemble the winch or brake for any reason. Disassembly of the winch or brake before contacting Thern, Inc. voids all warranties.

problem	cause	correction
handle turns, drum doesn't turn	<ul style="list-style-type: none"> • loose or broken spring pins • loose, stripped or broken gears 	<ul style="list-style-type: none"> inspect winch and brake, repair as necessary inspect gears and repair as necessary
handle turns hard or not at all	<ul style="list-style-type: none"> • ratchet on winch engaged • load too heavy • spring pins loose or broken on winch or brake • disc brake damaged or locked • gears or bearings broken or locked 	<ul style="list-style-type: none"> disengage winch ratchet lighten load inspect winch and brake, repair as necessary inspect brake, repair as necessary inspect and repair as necessary
brake does not operate properly	<ul style="list-style-type: none"> • friction discs worn or damaged. • friction discs damaged from over lubrication • disc brake ratchet pawl damaged. 	<ul style="list-style-type: none"> inspect and replace as necessary inspect and replace as necessary inspect and repair as necessary
excessively worn gears or bearings (excessive backlash)	<ul style="list-style-type: none"> • load too heavy • poor lubrication of gears or bearings 	<ul style="list-style-type: none"> lighten load inspect and relubricate as necessary
overheating	<ul style="list-style-type: none"> • operated too long without rest • load too heavy • poor lubrication. • bearing seized up. 	<ul style="list-style-type: none"> allow to cool lighten load inspect and lubricate as necessary inspect and replace as necessary
unusual noises		
high pitched squeak	<ul style="list-style-type: none"> • poor lubrication. 	<ul style="list-style-type: none"> inspect and relubricate as necessary
grinding noise	<ul style="list-style-type: none"> • contaminated lubrication • dirt in brake or winch gears • broken gears or bearings 	<ul style="list-style-type: none"> clean and relubricate winch inspect and clean as necessary inspect and replace as necessary
rattling noise	<ul style="list-style-type: none"> • loose bolts, set screws or other fasteners 	<ul style="list-style-type: none"> tighten all bolts and other fasteners
uneven clicking noise in brake	<ul style="list-style-type: none"> • broken gear tooth in brake 	<ul style="list-style-type: none"> inspect and repair as necessary
weak clicking noise in brake	<ul style="list-style-type: none"> • spring or ratchet pawl dirty or damaged. • worn brake ratchet pawl, gear, or spring 	<ul style="list-style-type: none"> inspect and clean or repair as necessary inspect and replace as necessary
no clicking noise in brake	<ul style="list-style-type: none"> • ratchet incorrectly installed. • ratchet pawl damaged or worn excessively 	<ul style="list-style-type: none"> disassemble and install correctly inspect and replace as necessary

Spur Gear Hand Winch Performance Characteristics ¹ Imperial

model number	description	load rating (lb)			wire rope dia. (in)	drum capacity (ft) ²			single gear ratio	double gear ratio	force ³ to lift 1000 lb	approx. ship wt. (lb)
		1st layer	mid drum	full drum		1st layer	mid drum	full drum				
M4022	1000 lb – marine duty (for pulling only)	1000	700	500	1/8 3/16	4 3	52 26	130 57	2.85:1	—	40 lb	12
M4022PB	1000 lb – marine duty with brake (for lifting)	1000	700	500	1/8 3/16	4 3	52 26	130 57	2.85:1	—	41 lb	17
M4032	1000 lb – marine duty (for pulling only)	1000	700	500	1/8 3/16	11 7	110 51	250 110	2.85:1	—	40 lb	14
M4032PB	1000 lb – marine duty with brake (for lifting)	1000	700	500	1/8 3/16	11 7	110 51	250 110	2.85:1	—	41 lb	18
M4042PBSS	1000 lb – stainless steel with brake (for lifting)	1000	800	600	1/8 3/16 1/4	12 8 5	110 48 27	240 110 59	3.83:1	—	46 lb (single gear)	24
M4312	2000 lb – marine duty (for pulling only)	2000	1600	1200	3/16 1/4 5/16	8 5 4	48 27 17	110 59 39	3.83:1	14.7:1	20 lb (double gear)	23
M4312PB	2000 lb – marine duty with brake (for lifting)	2000	1600	1200	3/16 1/4 5/16	8 5 4	48 27 17	110 59 39	—	14.7:1	17 lb (double gear)	28
M4312PBSS	2000 lb – stainless steel with brake (for lifting)	2000	1600	1200	3/16 1/4 5/16	8 5 4	48 27 17	110 59 39	—	14.7:1	17 lb (double gear)	28
M4412	2000 lb – marine duty (for pulling only)	2000	1600	1200	3/16 1/4 5/16	18 14 11	97 52 35	210 120 77	3.83:1	14.7:1	20 lb (double gear)	25
M4412PB	2000 lb – marine duty with brake (for lifting)	2000	1600	1200	3/16 1/4 5/16	18 14 11	97 52 35	210 120 77	—	14.7:1	17 lb (double gear)	30

¹ Performance Characteristics are for standard products referred to in this manual. Non-standard products may vary from the original design. Contact Thern, Inc. for this information.

² Actual drum capacities may be 25-30% less, due to nonuniform winding. Wire rope tension will also affect drum capacity.

³ Approximate handle force required to lift 1000 lb with an empty drum, and maximum handle length.

Spur Gear Hand Winch Performance Characteristics ¹ Metric

model number	description	load rating (kg)			wire rope dia. (mm)	drum capacity (m) ²			single gear ratio	double gear ratio	force ³ to lift 450 kg	approx. ship wt. (kg)
		1st layer	mid drum	full drum		1st layer	mid drum	full drum				
M4022	450 kg – marine duty (for pulling only)	450	315	225	3 5	1.2 0.9	52 26	15.8 7.9	2.85:1	—	19	6
M4022PB	450 kg – marine duty with brake (for lifting)	450	315	225	3 5	1.2 0.9	52 26	15.8 7.9	2.85:1	—	19	8
M4032	450 kg – marine duty (for pulling only)	450	315	225	3 5	3.3 2.1	110 51	33.5 15.5	2.85:1	—	19	7
M4032PB	1450 kg – marine duty with brake (for lifting)	450	315	225	3 5	3.3 2.1	110 51	33.5 15.5	2.85:1	—	19	9
M4042PBSS	450 kg – stainless steel with brake (for lifting)	450	360	270	3 5 6	3.6 2.4 1.5	110 48 27	33.5 14.6 8.2	3.83:1	—	21 (single gear)	10
M4312	905 kg – marine duty (for pulling only)	905	725	540	5 6 8	2.4 1.5 1.2	48 27 17	14.6 8.2 5.1	3.83:1	14.7:1	10 (double gear)	11
M4312PB	905 kg – marine duty with brake (for lifting)	905	725	540	5 6 8	2.4 1.5 1.2	48 27 17	14.6 8.2 5.1	—	14.7:1	8 (double gear)	13
M4312PBSS	905 kg – stainless steel with brake (for lifting)	905	725	540	5 6 8	2.4 1.5 1.2	48 27 17	14.6 8.2 5.1	—	14.7:1	8 (double gear)	13
M4412	905 kg – marine duty (for pulling only)	905	725	540	5 6 8	5.4 4.2 3.3	97 52 35	29.5 15.8 10.6	3.83:1	14.7:1	10 (double gear)	12
M4412PB	905 kg – marine duty with brake (for lifting)	905	725	540	5 6 8	5.4 4.2 3.3	97 52 35	29.5 15.8 10.6	—	14.7:1	8 (double gear)	14

¹ Performance Characteristics are for standard products referred to in this manual. Non-standard products may vary from the original design. Contact Thern, Inc. for this information.

² Actual drum capacities may be 25-30% less, due to nonuniform winding. Wire rope tension will also affect drum capacity.

³ Approximate handle force required to lift 450 kg with an empty drum, and maximum handle length.

Spur Gear Hand Winch		Model M4022			
ITEM	PART NUMBER	QTY	DESCRIPTION	MASS	
1	A25587	1	FRAME	2.64	
2	A25558	1	DRUM GEAR GUARD	.20	
3	A14146	1	CAPSCR BTNHD .250-20NC X .375 SST	.01	
4	A25588	1	DRUM ASSEMBLY	3.87	
5	A25591	1	SPACER DRUM .625DIA X 11GA X 3.235	.18	
6	A3333	1	CARIGBOLT .250-20NC X .500 SST	.01	
7	A5922	1	TIE DOWN	.04	
8	A3331	1	NUT HEX .250-20NC SST 18-8	.01	
9	A3492	1	CAPSCR HEXHD .375-16NC X 4.000 ZNPL GR5	.14	
10	A11913	1	NUT HEX JAM NYLK .375-16NC SST 18-8	.01	
11	A25676	1	RATCHET PIN	.26	
12	B1145	1	RATCHET SPRING	.01	
13	A25680	1	RATCHET PAWL	.08	
14	A3939	1	WASHER SPLK INT .375 X .692 X .035 SST	.00	
15	A3330	1	NUT HEX JAM .375-16NC SST 18-8	.01	
16	A1003	2	FLANGE BEARING	.07	
17	A25677	1	HANDLE SHAFT	.49	
18	A4136	2	RING RET EXT .625 SST	.00	
19	A25593	1	PINION STEEL SPUR M4021	.29	
20	A4851	1	PIN GROOVE TYPE A .187 X 1.375 ALYSTL	.01	
21	A25678	1	HANDLE ASSEMBLY	1.26	
22	A3327	1	WASHER HELSPRLK .625 X 1.086 X .156 SST	.03	
23	A3329	1	NUT HEX JAM .625-11NC SST 316	.07	
24	10477	1	LABEL DATE OF MANUFACTURE	.00	
25	A1978	1	LABEL WARNING	.00	
26	A2175	1	LABEL CAUTION THIS UNIT IS NOT FACTORY LUBRICATED	.00	
27	A2691	1	LABEL WARNING NO AUTOMATIC BRAKE	.00	
28	A25761	1	LABEL MODEL/CAPACITY M4022	.00	

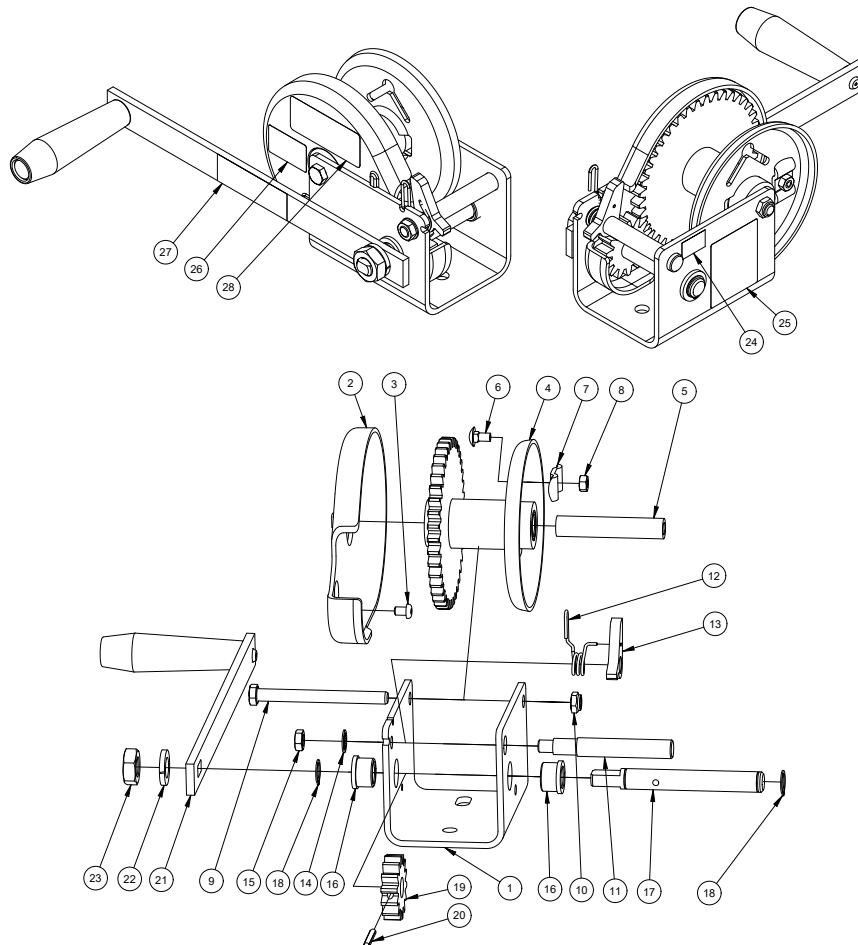

Spur Gear Hand Winch

Model M4032

ITEM	PART NUMBER	QTY	DESCRIPTION	MASS
1	A25666	1	FRAME	3.17
2	A25558	1	DRUM GEAR GUARD	.20
3	A14146	1	CAPSCR BTNHD .250-20NC X .375 SST	.01
4	A25668	1	DRUM ASSEMBLY	4.58
5	A25671	1	SPACER DRUM .625DIA X 11GA X 5.30	.29
6	A3333	1	CARIGBOLT .250-20NC X .500 SST	.01
7	A5922	1	TIE DOWN	.04
8	A3331	1	NUT HEX .250-20NC SST 18-8	.01
9	A3520	1	CAPSCR HEXHD .375-16NC X 6.000 ZNPL GR5	.21
10	A11913	2	NUT HEX JAM NYLK .375-16NC SST 18-8	.01
11	A25686	1	RATCHET PIN	.41
12	B1145	1	RATCHET SPRING	.01
13	A25680	1	RATCHET PAWL	.08
14	A3939	1	WASHER SPLK INT .375 X .692 X .035 SST	.00
15	A3330	1	NUT HEX JAM .375-16NC SST 18-8	.01
16	A1003	2	FLANGE BEARING	.07
17	A25687	1	HANDLE SHAFT	.60
18	A4136	2	RING RET EXT .625 SST	.00
19	A25593	1	PINION STEEL SPUR M4021	.29
20	A4851	1	PIN GROOVE TYPE A .187 X 1.375 ALYSTL	.01
21	A25678	1	HANDLE ASSEMBLY	1.26
22	A3327	1	WASHER HELSPRLK .625 X 1.086 X .156 SST	.03
23	A3329	1	NUT HEX JAM .625-11NC SST 316	.07
24	10477	1	LABEL DATE OF MANUFACTURE	.00
25	A1978	1	LABEL WARNING	.00
26	A2175	1	LABEL CAUTION THIS UNIT IS NOT FACTORY LUBRICATED	.00
27	A2691	1	LABEL WARNING NO AUTOMATIC BRAKE	.00
28	A25765	1	LABEL MODEL/CAPACITY M4032	.00

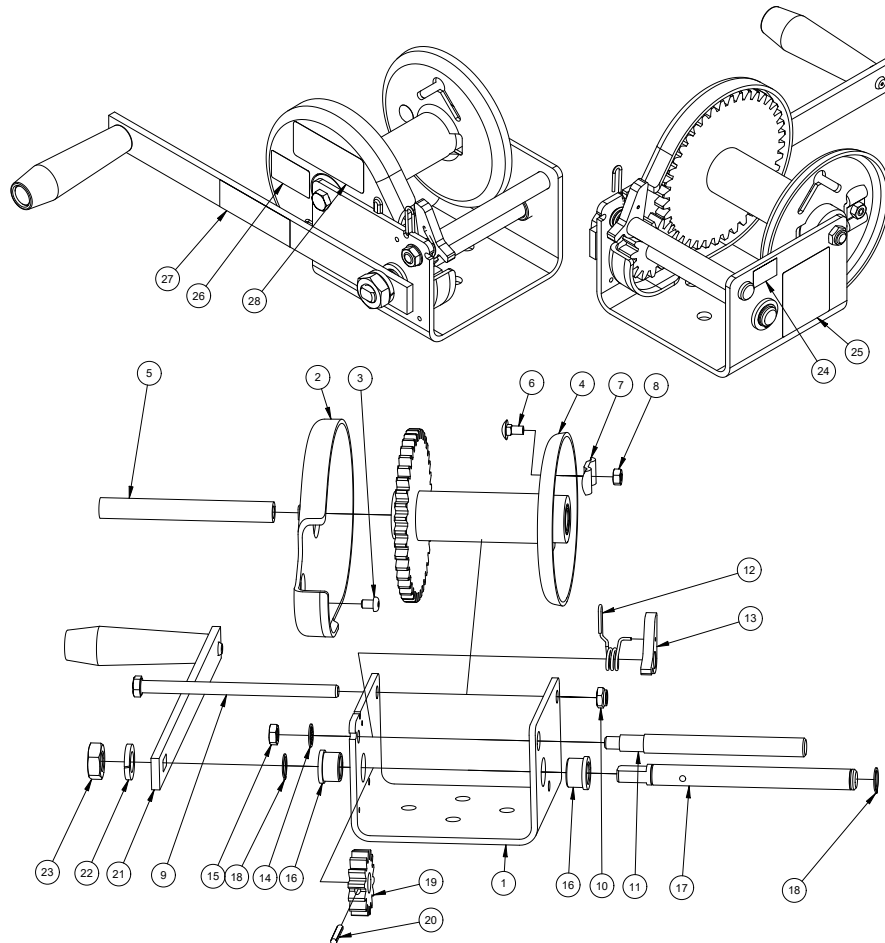

Spur Gear Hand Winch			Model M4022PB		
ITEM	PART NUMBER	QTY (4022PB)	QTY (4022PB-K)	DESCRIPTION	MASS
1	A25587	1	1	FRAME	2.64
2	A25506	1	1	DRUM GEAR GUARD	.22
3	A25661	1	1	ZERK .25-28 UNF SST	.01
4	A14146	1	1	CAPSCR BTNHD .250-20NC X .375 SST	.01
5	A25588	1	1	DRUM ASSEMBLY	3.87
6	A25591	1	1	SPACER DRUM .625DIA X 11GA X 3.235	.18
7	A3333	1	1	CARIGBOLT .250-20NC X .500 SST	.01
8	A5922	1	1	TIE DOWN	.04
9	A3331	1	1	NUT HEX .250-20NC SST 18-8	.01
10	A3519	1	1	CAPSCR HEXHD .375-16NC X 5.500 ZNPL GR5	.19
12	A25603	1	1	SPACER .391ID X .560D X 1.212	.07
13	A11913	1	1	NUT HEX JAM NYLK .375-16NC SST 18-8	.01
14	A1003	2	2	FLANGE BEARING	.07
15	A25592	1	1	INPUT SHAFT	.66
16	A25593	1	1	PINION STEEL SPUR M4021	.29
17	A22352	1	1	PIN GROOVE TYPE A .187 X 1.250 SST	.01
18	A4136	1	1	RING RET EXT .625 SST	.00
19	A25594	1	1	DISC BRAKE ASSEMBLY	3.96
20	A22351	1	1	PIN GROOVE TYPE A .187 X 2.000 SST	.02
21	A25604	1	1	HANDLE MEDALLION ASSEMBLY	2.32
22	10477	1	1	LABEL DATE OF MANUFACTURE	.00
23	A2175	1	1	LABEL CAUTION THIS UNIT IS NOT FACTORY LUBRICATED	.00
24	A1978	1	1	LABEL WARNING	.00
25	A25757	1	0	LABEL MODEL/CAPACITY CE M4022PB	.00
26	A25758	0	1	LABEL MODEL/CAPACITY CE M4022PB-K	.00

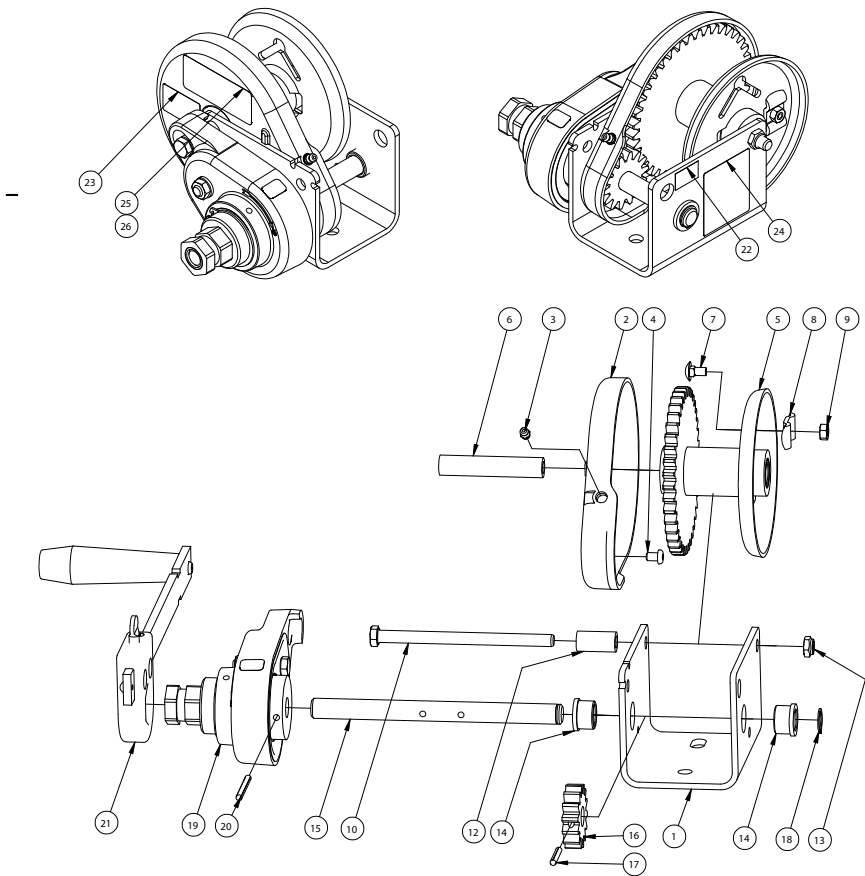

Spur Gear Hand Winch			Model M4032PB		
ITEM	PART NUMBER	QTY (4032PB)	QTY (4032PB-K)	DESCRIPTION	MASS
1	A25666	1	1	FRAME	3.16
2	A25506	1	1	DRUM GEAR GUARD	.22
3	A25661	1	1	ZERK .25-28 UNF SST	.01
4	A14146	1	1	CAPSCR BTNHD .250-20NC X .375 SST	.01
5	A25668	1	1	DRUM ASSEMBLY	4.58
6	A25671	1	1	SPACER DRUM .625DIA X 11GA X 5.30	.29
7	A3333	1	1	CARIGBOLT .250-20NC X .500 SST	.01
8	A5922	1	1	TIE DOWN	.04
9	A3331	1	1	NUT HEX .250-20NC SST 18-8	.01
10	A11913	1	1	NUT HEX JAM NYLK .375-16NC SST 18-8	.01
11	A3528	1	1	CAPSCR HEXHD .375-16NC X 7.500 ZNPL GR5	.25
12	A25603	1	1	SPACER .391ID X .56OD X 1.212	.07
15	A1003	2	2	FLANGE BEARING	.07
16	A25667	1	1	INPUT SHAFT	.83
17	A25593	1	1	PINION STEEL SPUR M4021	.29
18	A22352	1	1	PIN GROOVE TYPE A .187 X 1.250 SST	.01
19	A4136	1	1	RING RET EXT .625 SST	.00
20	A25594	1	1	DISC BRAKE ASSEMBLY	3.96
21	A22351	1	1	PIN GROOVE TYPE A .187 X 2.000 SST	.02
22	A25604	1	1	HANDLE MEDALLION ASSEMBLY	2.32
23	10477	1	1	LABEL DATE OF MANUFACTURE	.00
24	A2175	1	1	LABEL CAUTION THIS UNIT IS NOT FACTORY LUBRICATED	.00
25	A1978	1	1	LABEL WARNING	.00
26	A25763	1	0	LABEL MODEL/CAPACITY CE M4032PB	.00
27	A25764	0	1	LABEL MODEL/CAPACITY CE M4032PB-K	.00

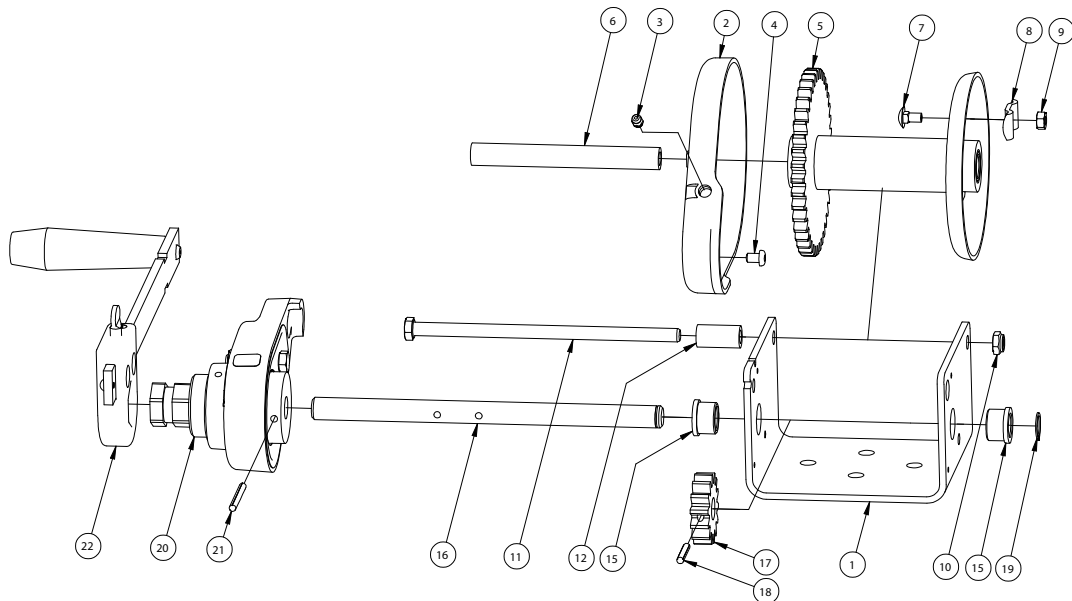
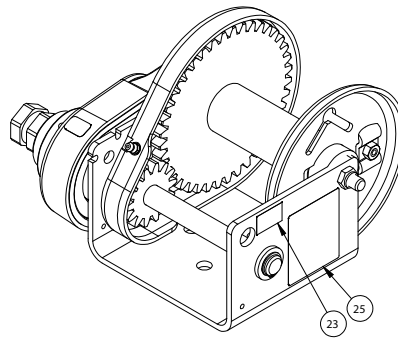
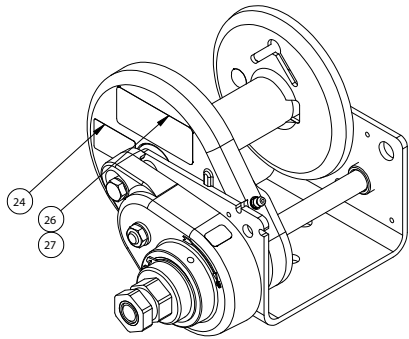

Spur Gear Hand Winch			Model M4042PBSS		
ITEM	PART NUMBER	QTY (4042PBSS)	QTY (4042PBSS-K)	DESCRIPTION	MASS
1	B4217	1	1	HANDLE MEDALLION ASSEMBLY	2.42
2	C3825	1	1	DISC BRAKE ASSEMBLY	4.27
3	A4420	2	2	BEARING HOUSING ASSEMBLY	.43
4	B2415	1	1	COUNTER SHAFT WELDMENT	1.44
5	A25579	1	1	FRAME	4.08
6	A25575	1	1	DRUM ASSEMBLY	7.50
7	A25509	1	1	DRUM GEAR GUARD	.26
8	A14146	1	1	CAPSCR BTNHD .250-20NC X .375 SST	.01
9	A25661	1	1	ZERK .25-28 UNF SST	.01
10	A3886	1	1	NUT HEX JAM .750-16NF SST 18-8	.09
11	A2846	1	1	CARIGBOLT .250-20NC X .750 SST	.02
12	A5922	1	1	TIE DOWN	.04
13	A3331	1	1	NUT HEX .250-20NC SST 18-8	.01
14	B2410	1	1	DRUM SHAFT	1.10
15	A4946	1	1	PIN GROOVE TYPE A .250 X 2.000 SST	.03
16	A4409	2	2	RING RET EXT 1.875 SST	.02
17	A4408	1	1	RING RET EXT .750 SST	.00
18	A25772	1	0	LABEL MODEL/CAPACITY CE M4042PBSS	.00
19	A25773	0	1	LABEL MODEL/CAPACITY CE M4042PBSS-K	.00
20	A2175	1	1	LABEL CAUTION THIS UNIT IS NOT FACTORY LUBRICATED	.00
21	A1978	1	1	LABEL WARNING	.00
22	10477	1	1	LABEL DATE OF MANUFACTURE	.00

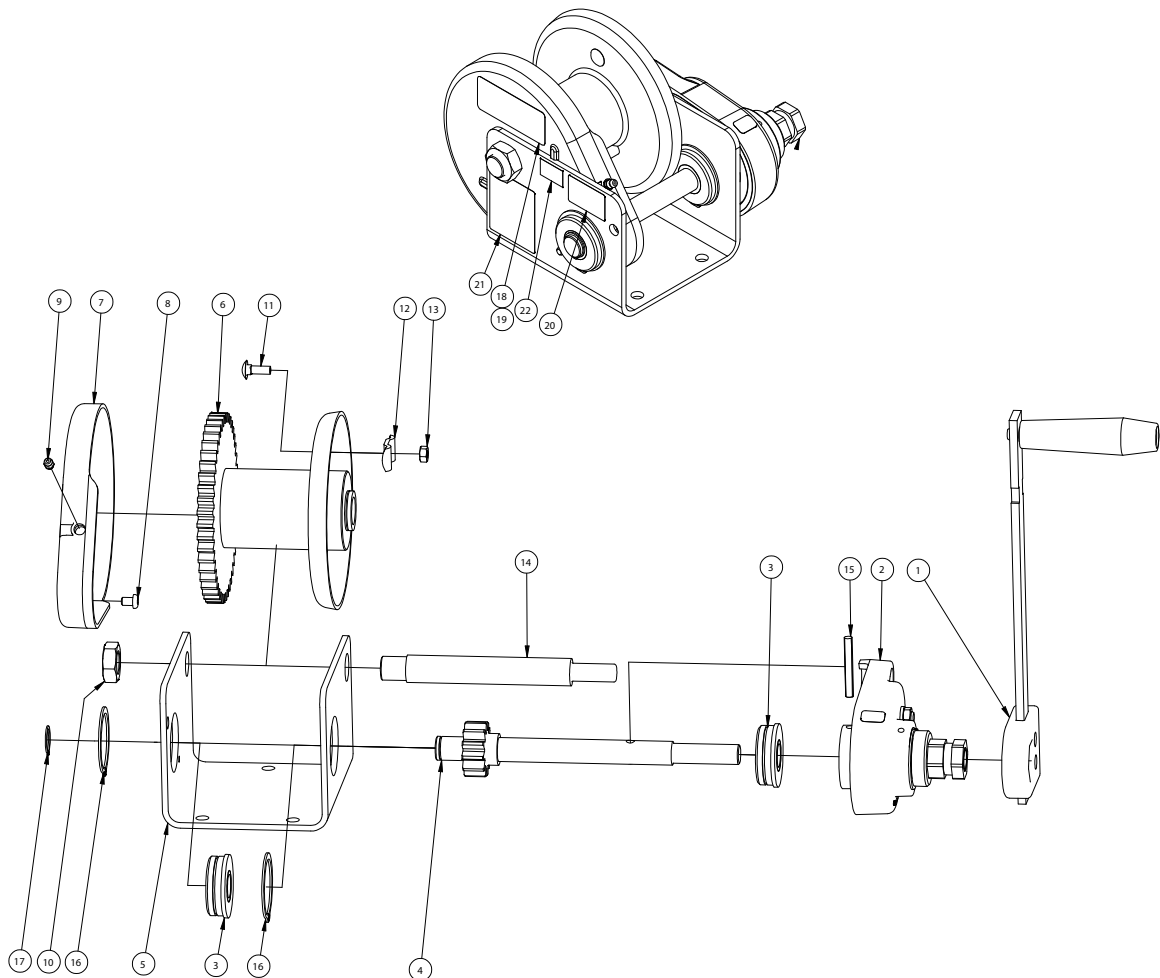

Spur Gear Hand Winch

Model M4312

ITEM	PART NUMBER	QTY	DESCRIPTION	MASS
1	A25616	1	DRUM ASSEMBLY	7.34
2	A25703	1	SHAFT DRUM M4312PB X 3.00 LG DRUM NORLS	1.10
3	A3886	2	NUT HEX JAM .750-16NF SST 18-8	.09
4	A2846	1	CARIGBOLT .250-20NC X .750 SST	.02
5	A5922	1	TIE DOWN	.04
6	A3331	1	NUT HEX .250-20NC SST 18-8	.01
7	A25661	1	ZERK .25-28 UNF SST	.01
8	A25508	1	COUNTER SHAFT GEAR GUARD	.30
9	A25557	2	CAPSCR BTNHD .250-20NC X 1.375 SST 18-8	.02
10	A25614	1	RIGHT SIDE FRAME PLATE	1.91
11	A25627	1	FRAME ROD M4312, M4312PB	.43
12	A3939	2	WASHER SPLK INT .375 X .692 X .035 SST	.00
13	A3330	2	NUT HEX JAM .375-16NC SST 18-8	.01
14	A25626	1	COUNTER SHAFT ASSEMBLY	4.49
15	A25615	1	LEFT SIDE FRAME PLATE	1.91
16	A14146	1	CAPSCR BTNHD .250-20NC X .375 SST	.01
17	A25620	1	BEARING HOLDER ASSEMBLY	.36
18	A3883	2	RING RET EXT 1.750 SST	.01
19	A4408	1	RING RET EXT .750 SST	.00
20	B1145	1	RATCHET SPRING	.01
21	A25680	1	RATCHET PAWL	.08
22	A25559	1	DRUM GEAR GUARD	.24
23	A25704	1	HANDLE ASSEMBLY	1.66
24	A4665	1	PIN COTTER HAIR	.01
25	A4290	1	PIN SLOTTED SPRING .250 X .750 SST	.01
26	A2175	LABEL CAUTION THIS UNIT IS NOT FACTORY LUBRICATED	.00	
27	A1978	1	LABEL WARNING	.00
28	10477	1	LABEL DATE OF MANUFACTURE	.00
29	A25766	1	LABEL MODEL/CAPACITY M4312	.00

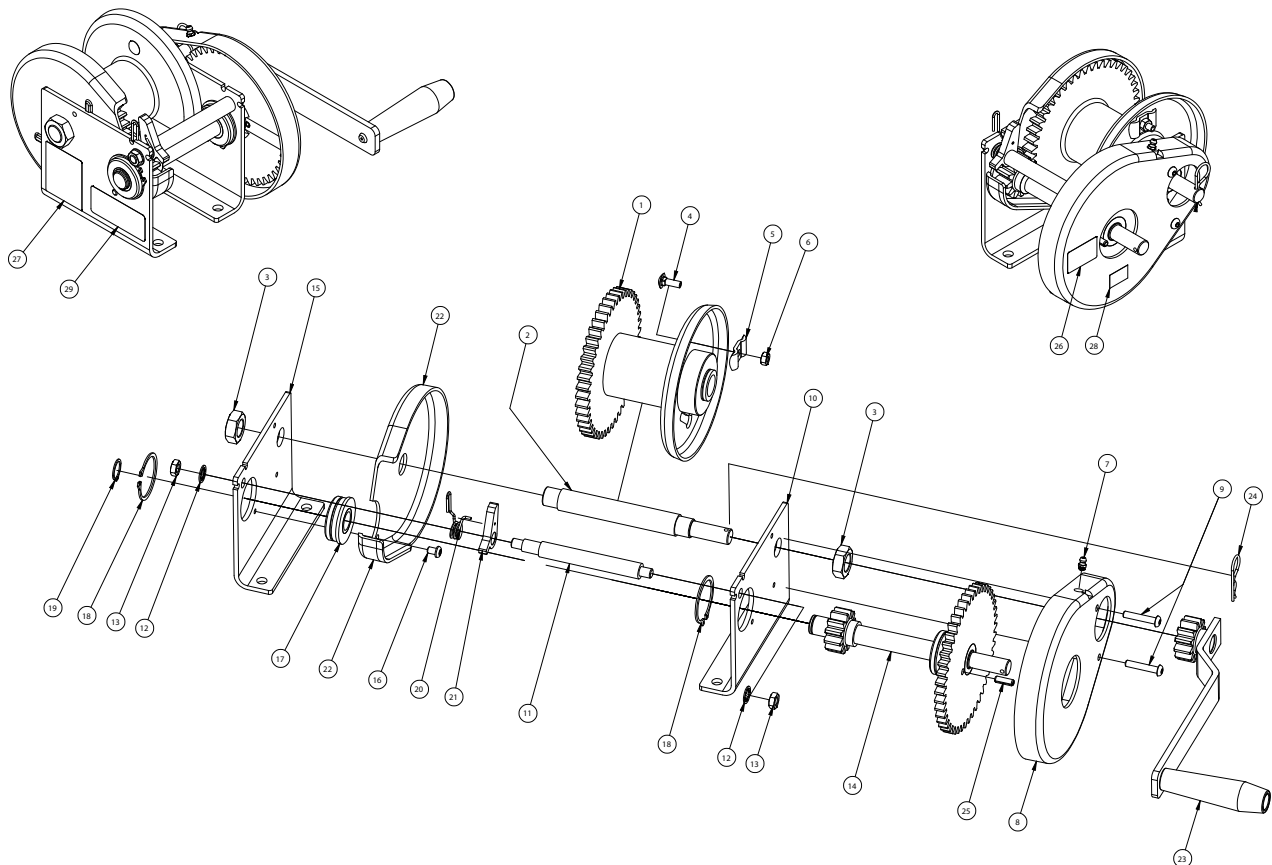

Spur Gear Hand Winch		Model M4412		
ITEM	PART NUMBER	QTY	DESCRIPTION	MASS
1	A25689	1	DRUM ASSEMBLY	8.85
2	A25708	1	SHAFT DRUM M4412PB X 3.00 LG DRUM NORLS	1.60
3	A3886	2	NUT HEX JAM .750-16NF SST 18-8	.09
4	A2846	1	CARIGBOLT .250-20NC X .750 SST	.02
5	A5922	1	TIE DOWN	.04
6	A3331	1	NUT HEX .250-20NC SST 18-8	.01
7	A25661	1	ZERK .25-28 UNF SST	.01
8	A25508	1	COUNTER SHAFT GEAR GUARD	.30
9	A25557	2	CAPSCR BTNHD .250-20NC X 1.375 SST 18-8	.02
10	A25614	1	RIGHT SIDE FRAME PLATE	1.91
11	A25695	1	FRAME ROD M4412,M4412PB	.69
12	A3939	2	WASHER SPLK INT .375 X .692 X .035 SST	.00
13	A3330	2	NUT HEX JAM .375-16NC SST 18-8	.01
14	A25692	1	COUNTER SHAFT ASSEMBLY M4412	4.87
15	A25615	1	LEFT SIDE FRAME PLATE	1.91
16	A25559	1	DRUM GEAR GUARD	.24
17	A14146	1	CAPSCR BTNHD .250-20NC X .375 SST	.01
18	A25620	1	BEARING HOLDER ASSEMBLY	.36
19	A3883	2	RING RET EXT 1.750 SST	.01
20	A4408	1	RING RET EXT .750 SST	.00
21	A25680	1	RATCHET PAWL	.08
22	B1145	1	RATCHET SPRING	.01
23	A25704	1	HANDLE ASSEMBLY	1.66
24	A4665	1	PIN COTTER HAIR	.01
25	A4290	1	PIN SLOTTED SPRING .250 X .750 SST	.01
26	10477	1	LABEL DATE OF MANUFACTURE	.00
27	A2175	1	LABEL CAUTION THIS UNIT IS NOT FACTORY LUBRICATED	.00
28	A1978	1	LABEL WARNING	.00
29	A25771	1	LABEL MODEL/CAPACITY M4412	.00

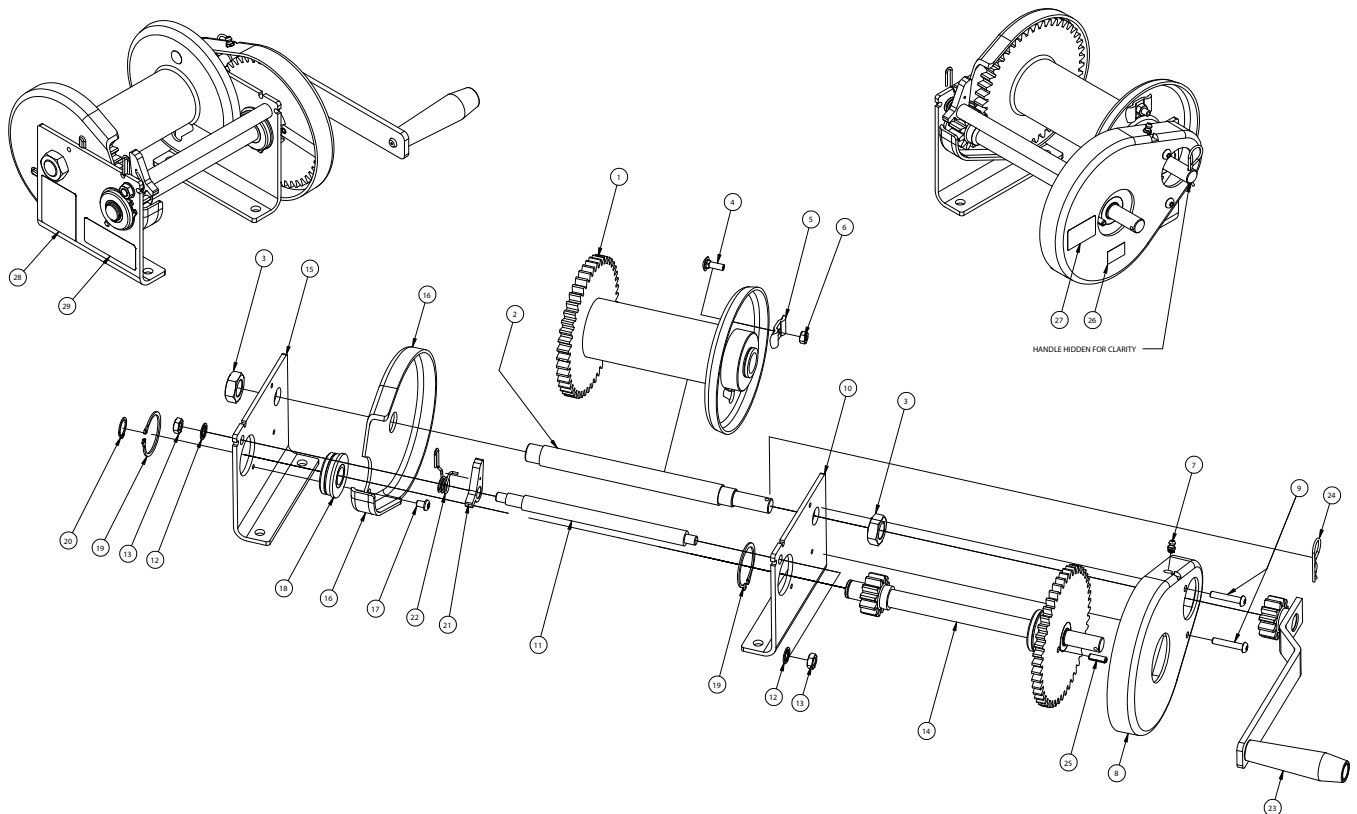

Spur Gear Hand Winch			Model M4312PB		
ITEM	PART NUMBER	QTY (4312PB)	QTY (4312PB-K)	DESCRIPTION	MASS
1	A25616	1	1	DRUM ASSEMBLY	7.34
2	A25613	1	1	SHAFT DRUM M4311PB X 3.00 LG DRUM NORLS	1.36
3	A3886	2	2	NUT HEX JAM .750-16NF SST 18-8	.09
4	A2846	1	1	CARIGBOLT .250-20NC X .750 SST	.02
5	A5922	1	1	TIE DOWN	.04
6	A3331	1	1	NUT HEX .250-20NC SST 18-8	.01
7	A25661	2	2	ZERK .25-28 UNF SST	.01
8	A25508	1	1	COUNTER SHAFT GEAR GUARD	.30
9	A25557	2	2	CAPSCR BTNHD .250-20NC X 1.375 SST 18-8	.02
10	A25614	1	1	RIGHT SIDE FRAME PLATE	1.91
11	A25627	1	1	FRAME ROD M4312, M4312PB	.43
12	A3939	2	2	WASHER SPLK INT .375 X .692 X .035 SST	.00
13	A3330	2	2	NUT HEX JAM .375-16NC SST 18-8	.01
14	A25626	1	1	COUNTER SHAFT ASSEMBLY	4.49
15	A25615	1	1	LEFT SIDE FRAME PLATE	1.91
16	A25507	1	1	DRUM GEAR GUARD	.26
17	A14146	1	1	CAPSCR BTNHD .250-20NC X .375 SST	.01
18	A25620	1	1	BEARING HOLDER ASSEMBLY	.36
19	A3883	2	2	RING RET EXT 1.750 SST	.01
20	A4408	1	1	RING RET EXT .750 SST	.00
21	A25610	1	1	BRAKE DISC ASSEMBLY	4.00
22	A5059	1	1	MACHBUSH .625 X 1.000 X 14GA SST	.01
23	A4282	1	1	PIN SLOTTED SPRING .187 X .750 SST	.00
24	A25604	1	1	HANDLE MEDALLION ASSEMBLY	2.32
25	A2175	1	1	LABEL CAUTION THIS UNIT IS NOT FACTORY LUBRICATED	.00
26	A1978	1	1	LABEL WARNING	.00
27	10477	1	1	LABEL DATE OF MANUFACTURE	.00
28	A25766	1	0	LABEL MODEL/CAPACITY CE M4312PB	.00
29	A25767	0	1	LABEL MODEL/CAPACITY CE M4312PB-K	.00

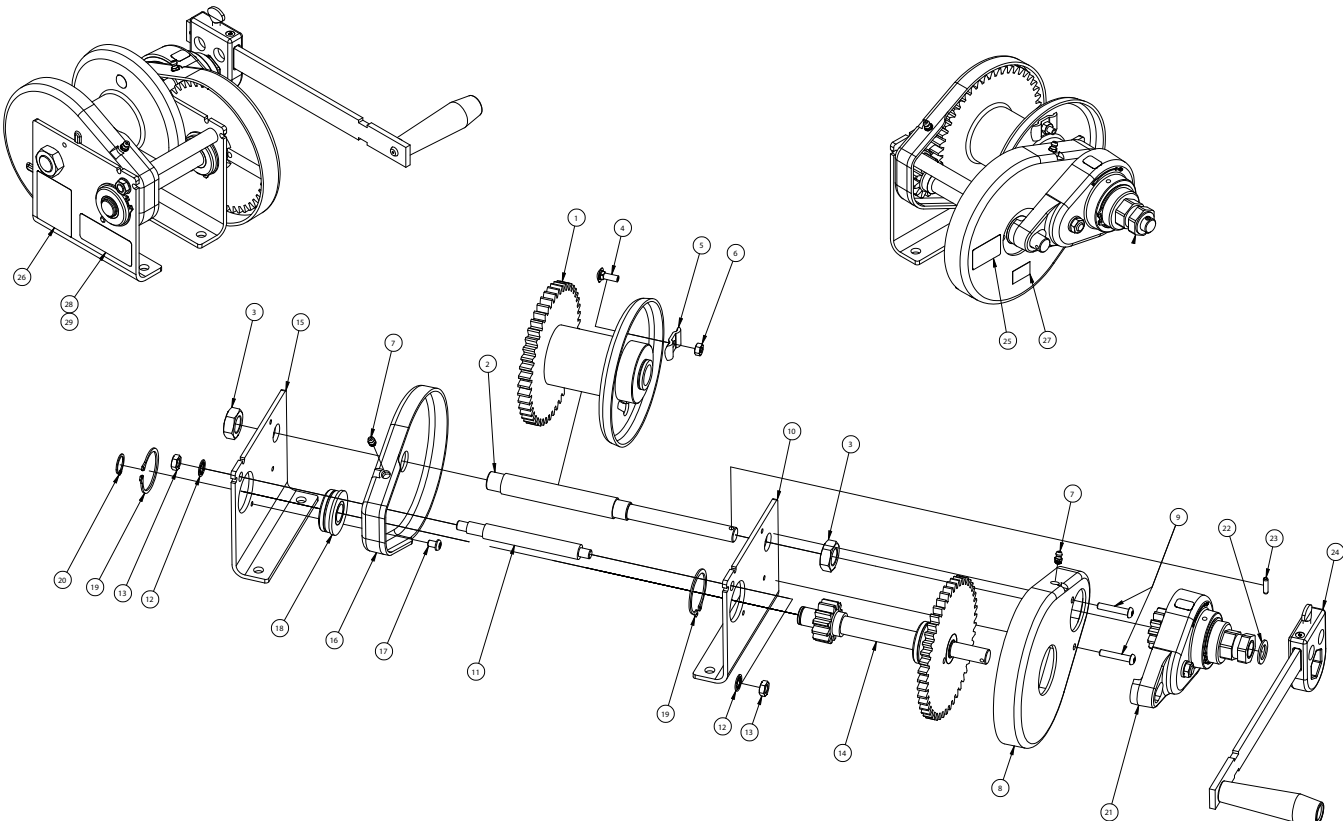

Spur Gear Hand Winch			Model M4412PB		
ITEM	PART NUMBER	QTY (4412PB)	QTY (4412PB-K)	DESCRIPTION	MASS
1	A25689	1	1	DRUM ASSEMBLY	8.85
2	A25691	1	1	SHAFT DRUM M4311PB X 3.00 LG DRUM NORLS	1.86
3	A3886	2	2	NUT HEX JAM .750-16NF SST 18-8	.09
4	A2846	1	1	CARIGBOLT .250-20NC X .750 SST	.02
5	A5922	1	1	TIE DOWN	.04
6	A3331	1	1	NUT HEX .250-20NC SST 18-8	.01
7	A25661	2	2	ZERK .25-28 UNF SST	.01
8	A25508	1	1	COUNTER SHAFT GEAR GUARD	.30
9	A25557	2	2	CAPSCR BTNHD .250-20NC X 1.375 SST 18-8	.02
10	A25614	1	1	RIGHT SIDE FRAME PLATE	1.91
11	A25695	1	1	FRAME ROD M4412,M4412PB	.69
12	A3939	2	2	WASHER SPLK INT .375 X .692 X .035 SST	.00
13	A3330	2	2	NUT HEX JAM .375-16NC SST 18-8	.01
14	A25692	1	1	COUNTER SHAFT ASSEMBLY M4412	4.87
15	A25615	1	1	LEFT SIDE FRAME PLATE	1.91
16	A25507	1	1	DRUM GEAR GUARD	.26
17	A14146	1	1	CAPSCR BTNHD .250-20NC X .375 SST	.01
18	A25620	1	1	BEARING HOLDER ASSEMBLY	.36
19	A3883	2	2	RING RET EXT 1.750 SST	.01
20	A4408	1	1	RING RET EXT .750 SST	.00
21	A25610	1	1	BRAKE DISC ASSEMBLY	4.00
22	A5059	1	1	MACHBUSH .625 X 1.000 X 14GA SST	.01
23	A4282	1	1	PIN SLOTTED SPRING .187 X .750 SST	.00
24	A25604	1	1	HANDLE MEDALLION ASSEMBLY	2.32
25	A2175	1	1	LABEL CAUTION THIS UNIT IS NOT FACTORY LUBRICATED	.00
26	A1978	1	1	LABEL WARNING	.00
27	10477	1	1	LABEL DATE OF MANUFACTURE	.00
28	A25770	0	1	LABEL MODEL/CAPACITY CE M4412PB-K	.00
29	A25769	1	0	LABEL MODEL/CAPACITY CE M4412PB	.00

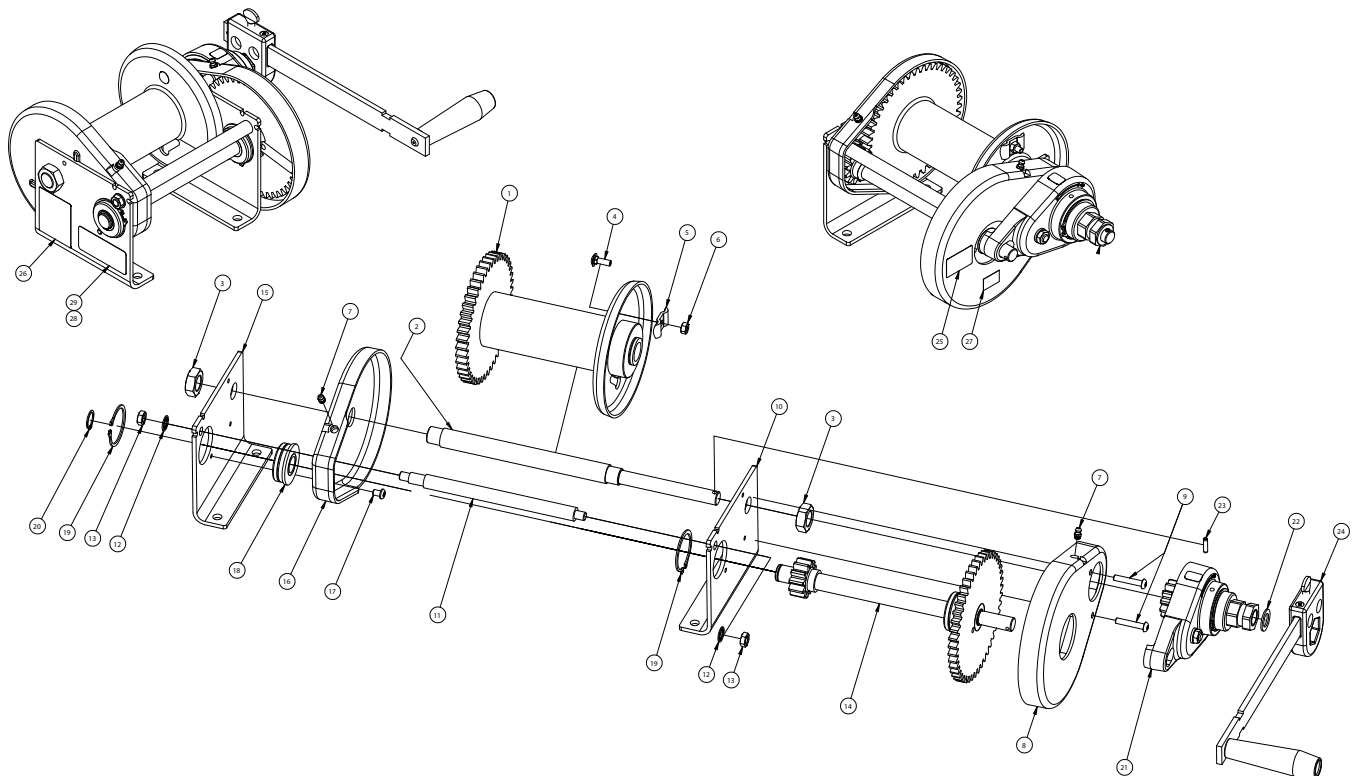

Spur Gear Hand Winch				Model M4312PBSS	
ITEM	PART NUMBER	QTY (4312PBSS)	QTY (4312PBSS-K)	DESCRIPTION	MASS
1	A25575	1	1	DRUM ASSEMBLY	7.50
2	B2474	1	1	SHAFT DRUM M4311PBSS	1.41
3	A3886	2	2	NUT HEX JAM .750-16NF SST 18-8 SST	.09
4	A2846	1	1	CARIGBOLT .250-20NC X .750 SST	.02
5	A5922	1	1	TIE DOWN	.04
6	A3331	1	1	NUT HEX .250-20NC SST 18-8 SST	.01
7	A25661	2	2	ZERK .25-28 UNF SST	.01
8	A25508	1	1	COUNTER SHAFT GEAR GUARD	.30
9	A25557	2	2	CAPSCR BTNHD .250-20NC X 1.375 SST	.02
10	A25664	1	1	RIGHT SIDE FRAME PLATE	1.95
11	B2476	1	1	FRAME ROD M4312, M4312PB	.37
12	A3939	2	2	WASHER SPLK INT .375 X .692 X .035 SST	.00
13	A3330	2	2	NUT HEX JAM .375-16NC 18-8 SST	.01
14	B2472	1	1	COUNTER SHAFT ASSEMBLY	4.56
15	A25615	1	1	LEFT SIDE FRAME PLATE	1.95
16	A25507	1	1	DRUM GEAR GUARD	.26
17	A14146	1	1	CAPSCR BTNHD .250-20NC X .375 SST	.01
18	A4599	1	1	BEARING HOLDER ASSEMBLY	.37
19	A3883	2	2	RING RET EXT 1.750 SST	.01
20	A4408	1	1	RING RET EXT .750 SST	.00
21	A27223	1	1	DISC BRAKE ASSEMBLY	4.28
22	A5059	1	1	MACHBUSH .625 X 1.000 X 14GA SST	.01
23	A4282	1	1	PIN SLOTTED SPRING .187 X .750 SST	.00
24	B4217	1	1	HANDLE MEDALLION ASSEMBLY	2.42
25	10477	1	1	LABEL DATE OF MANUFACTURE	.00
26	A2175	1	1	LABEL CAUTION THIS UNIT IS NOT FACTORY LUBRICATED	.00
27	A1978	1	1	LABEL WARNING	.00
28	A25774	1	0	LABEL MODEL/CAPACITY CE M4312PBSS	.00
29	A25775	0	1	LABEL MODEL/CAPACITY CE M4312PBSS-K	.00

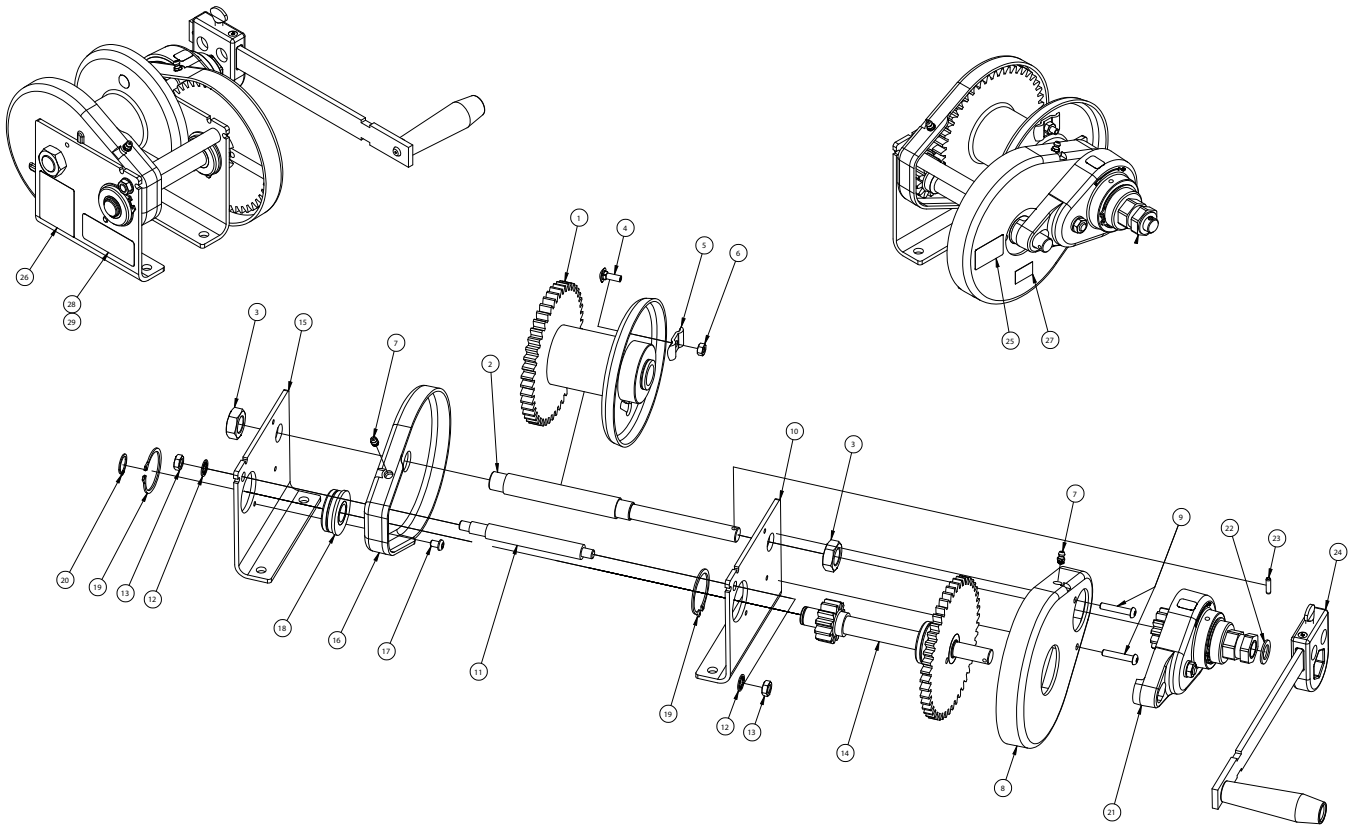

This Page is Intentionally Left Blank



Thern, Incorporated
Corporate Headquarters
& Manufacturing
5712 Industrial Park Road
Winona, MN USA
1-800-843-7648
Phone: 1-507-454-2996
www.thern.com

Thern Europe BV
Regional Headquarters
Amsterdam Schiphol Tetra
Siriusdreef 17-27, 2132 WT
Hoofddorp
The Netherlands
Phone: +31-546-898-380
europe@thern.com